

UCN detection and spin measurement for the TRIUMF neutron EDM experiment

nEDM Conference

Sean Hansen-Romu (Presenter & PhD student), Dr. Blair Jamieson

University of Winnipeg



THE UNIVERSITY OF
WINNIPEG

Contents

- Characterization of a scintillating lithium glass ultra-cold neutron detector
Jamieson et al. EPJ A (2017) 53:3.
- Results and conclusions
- Simultaneous spin analyzer for TRIUMF
- Design and current work
- Conclusion

nEDM is interesting

The nEDM measurement is leading edge science that provides an effective way to probe The Standard Model.

The neutron electric dipole moment experiment is motivated in part with the need for more CP violation necessary to help explain baryogenesis, the matter and anti-matter imbalance

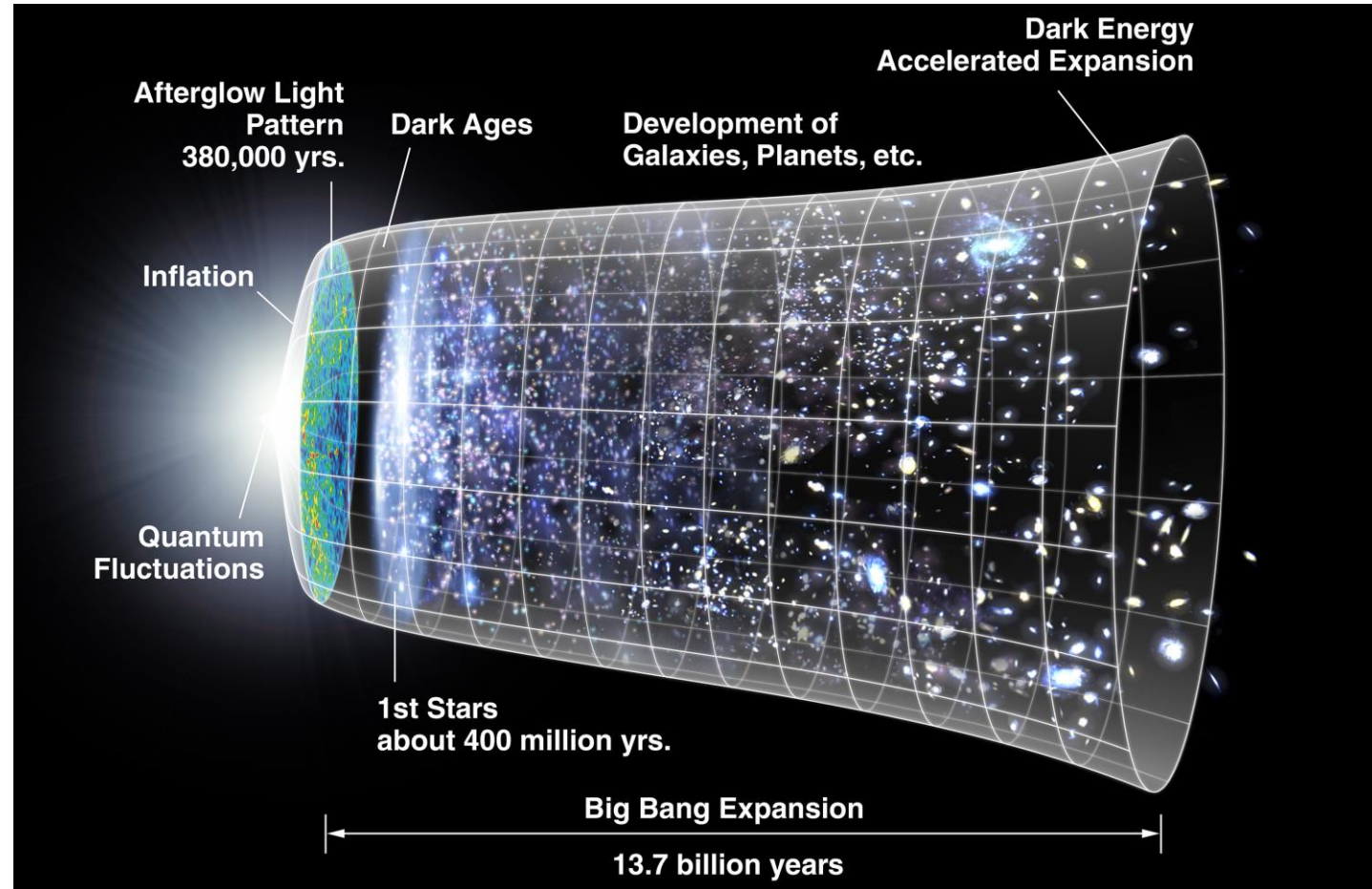

TRIUMF nEDM Measurement

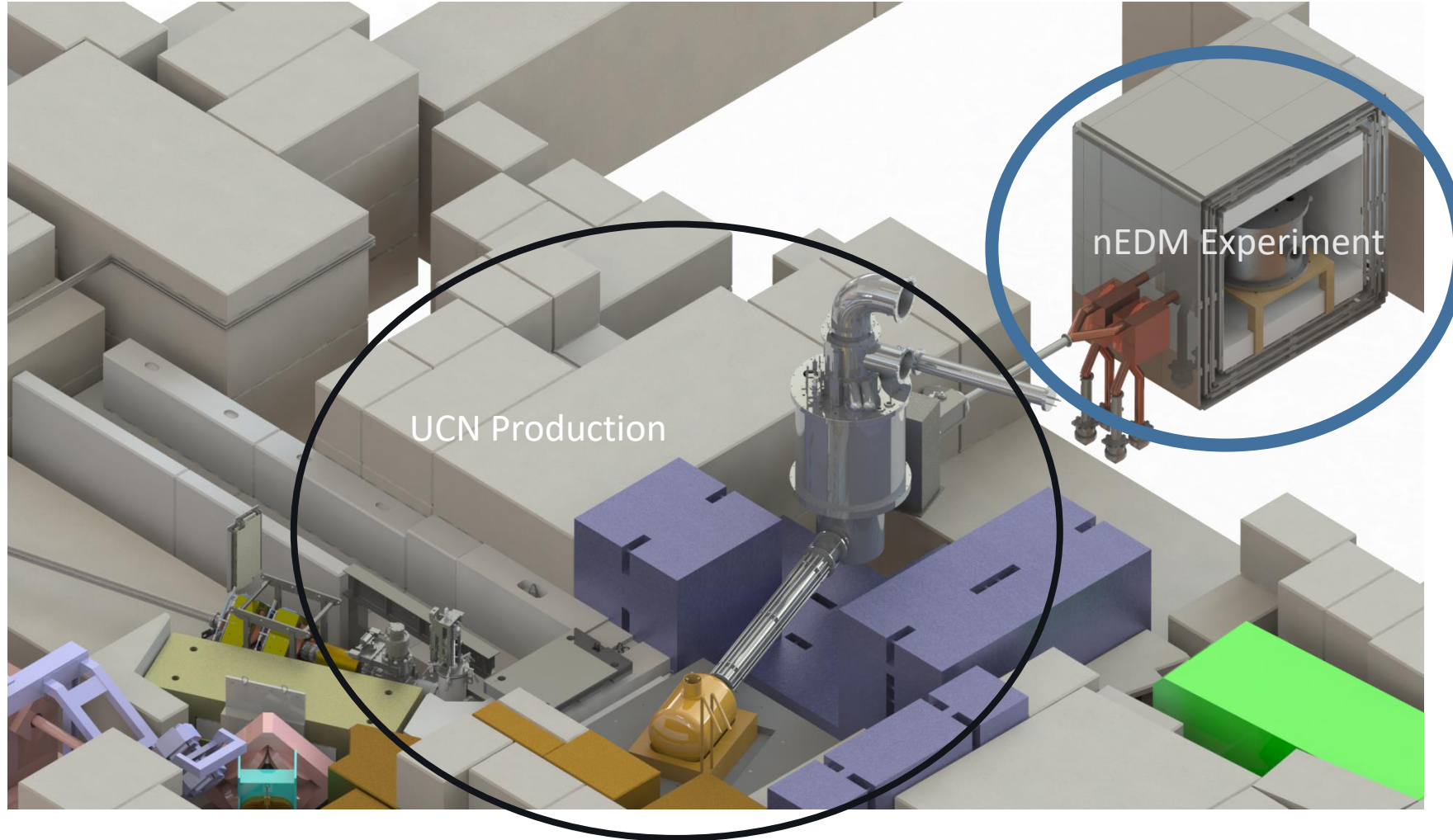

Location of the Detector System

Magnetically shielded room

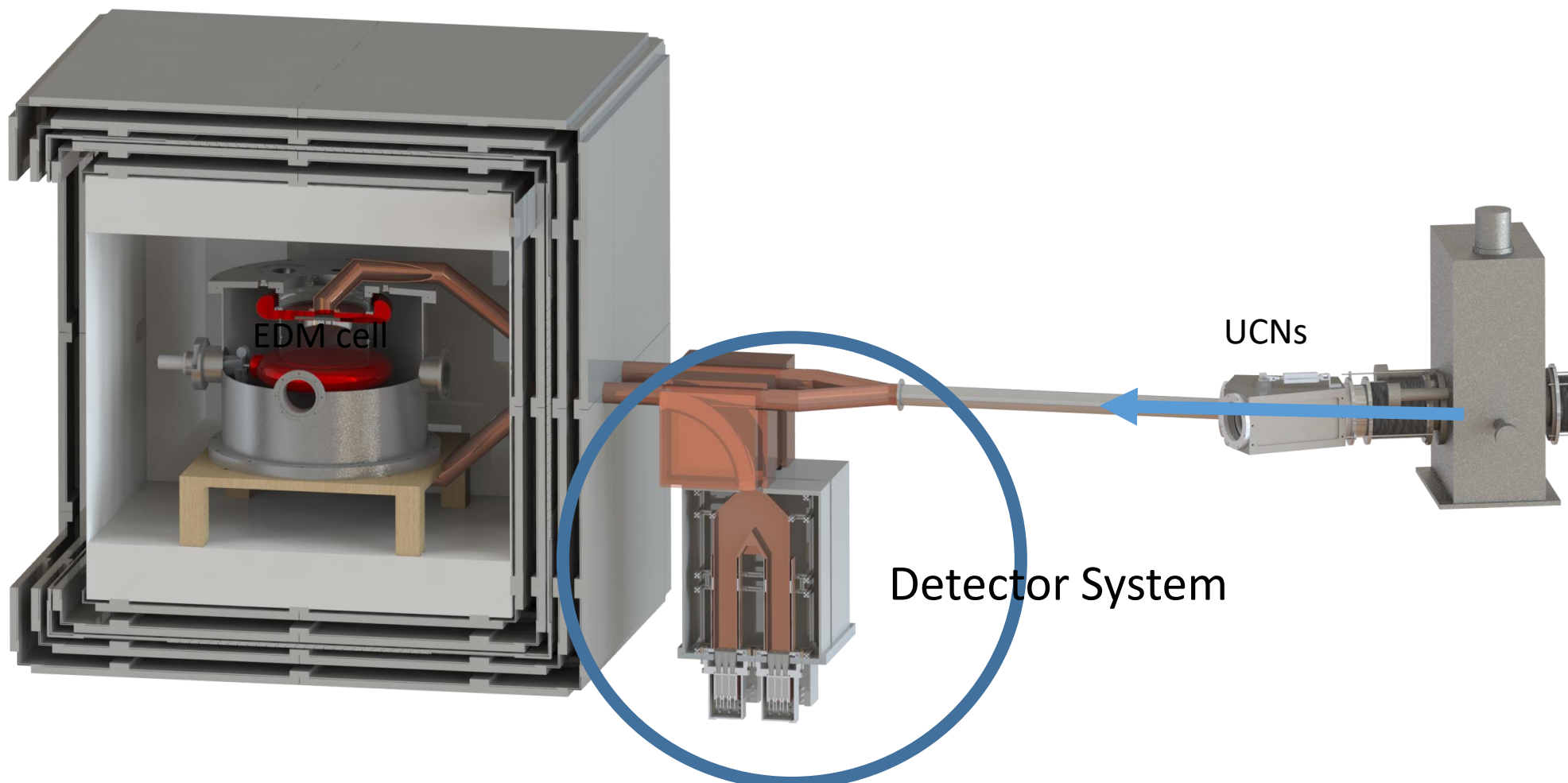

Simultaneous Spin Analyzer Background

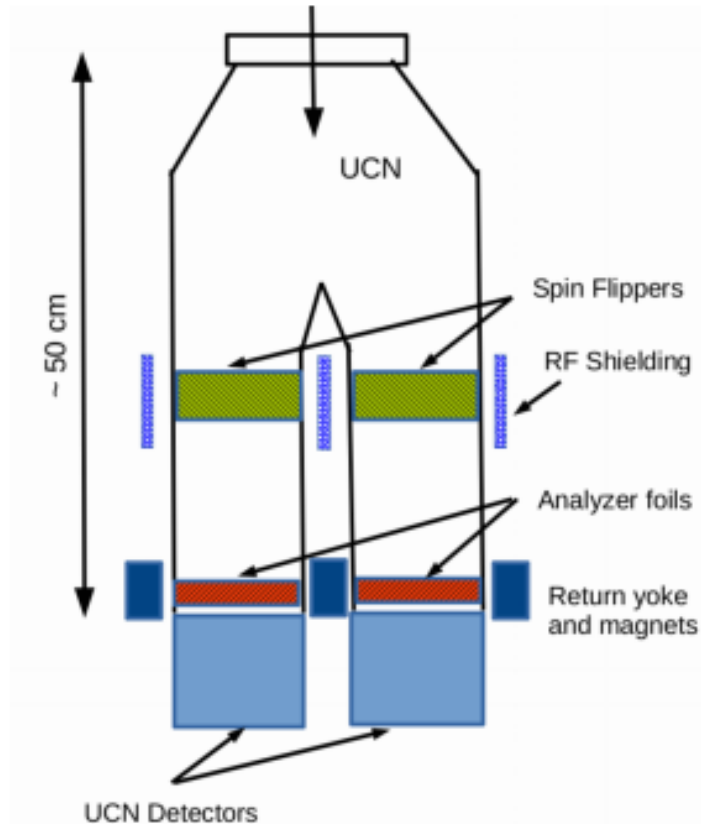

Afach, S., Ban, G., Bison, G. et al.
EPJ A (2015) 51:143

- Stat. Uncertainty in measured EDM is given by:
$$\sigma_{d_n} = \frac{\hbar}{2\alpha T E \sqrt{N_{tot}}}$$
- Increase N_{tot} by measuring both spin states simultaneously (less loss due to storage time)
- Increase alpha due to less depolarization while storing above analyzer foil
- Multiple spin flippers to study systematic uncertainties (in principle only one is needed)
- PSI group showed this gained 18% in stat. uncertainty

Slide from Dr. Blair
Jamieson CAP
congress 2015 6

Simultaneous Spin Analyzer for TRIUMF - current design

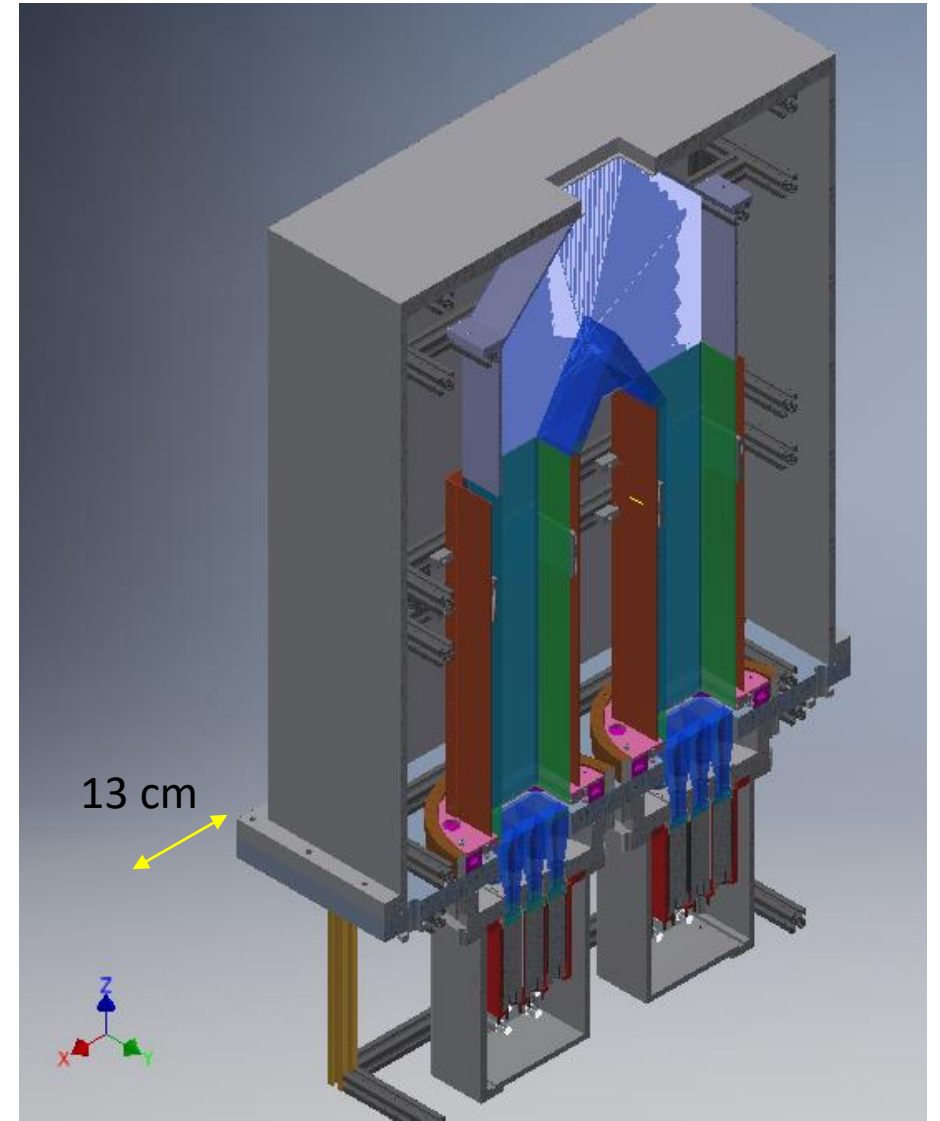
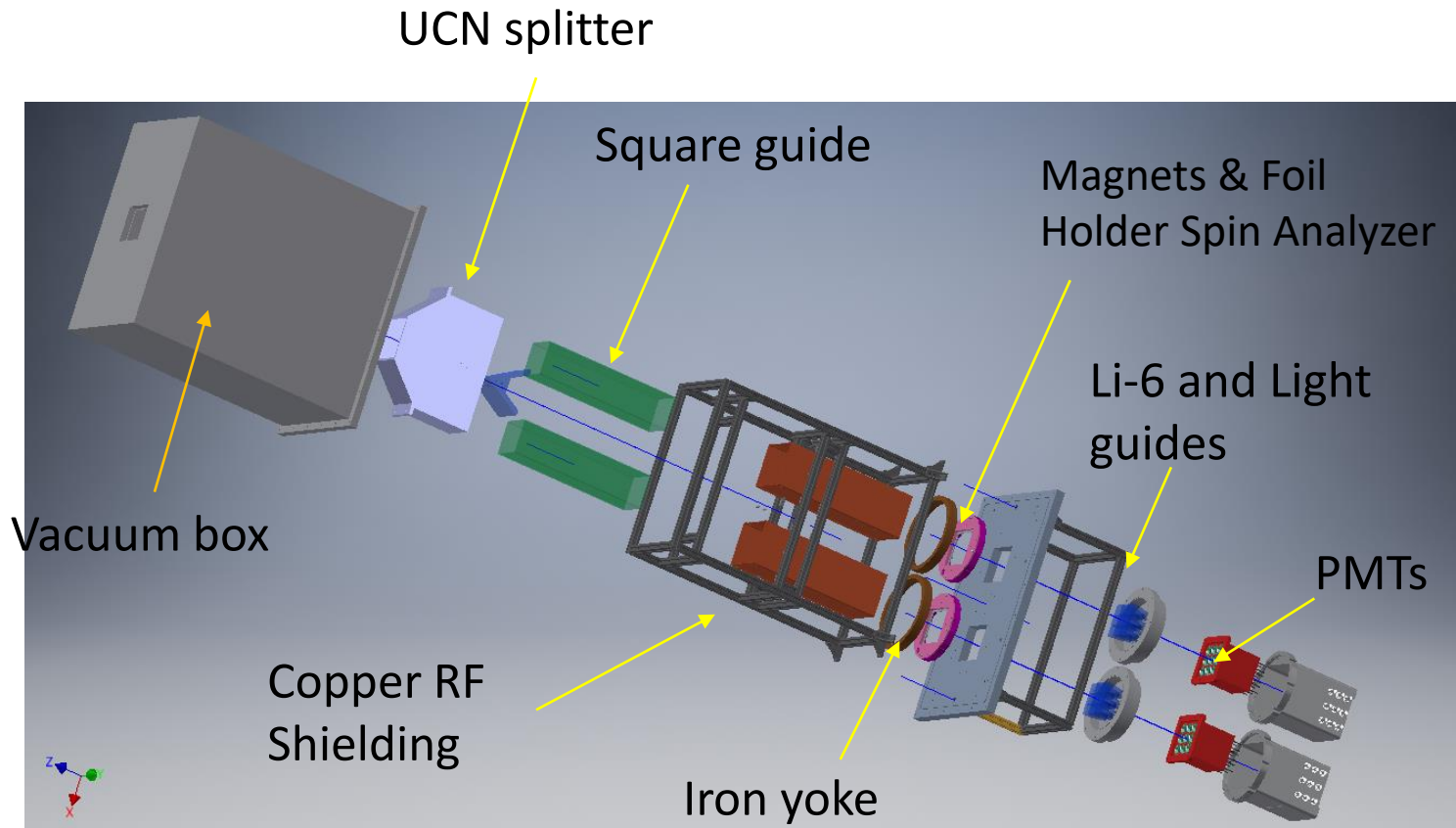

Li-6 Detector Requirements and Design

- Handle rate ~ 1.5 MHz and pile-up
- Account for background
- Better efficiency stability than statistical uncertainty
- Ability to normalize for changes (UCN density, drift in efficiency, UCN production, etc.)

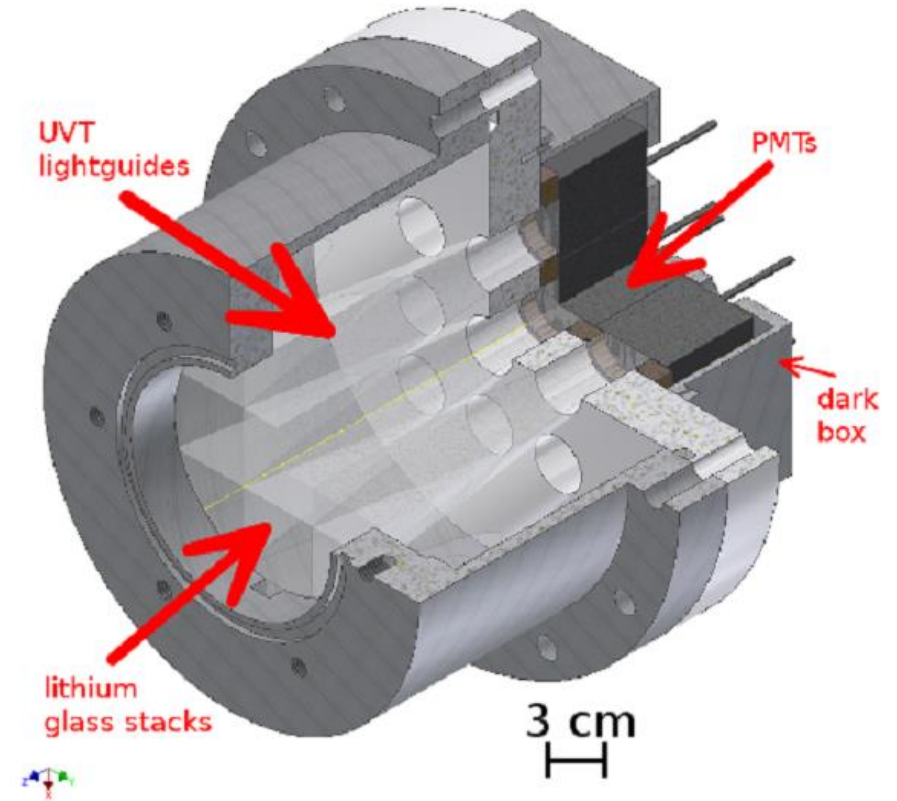

Made with aluminum (Al), a low density non-magnetic material

Lightguides are ultra-violent transmitting acrylic

The Li glass

Li-6 depleted

Li-6 Enriched

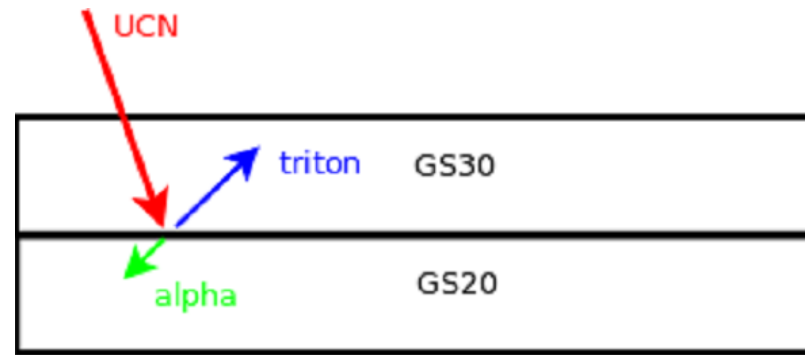

- Capture within 1-2 microns of the surface of the GS20 via:



- Full energy of triton and alpha produce scintillation light in the glass scintillator (very little edge effects)
- 100 um thick GS20 and 60 um thick GS30 optically contacted prepared by Thales-SESO (10 pieces 29 mm square)

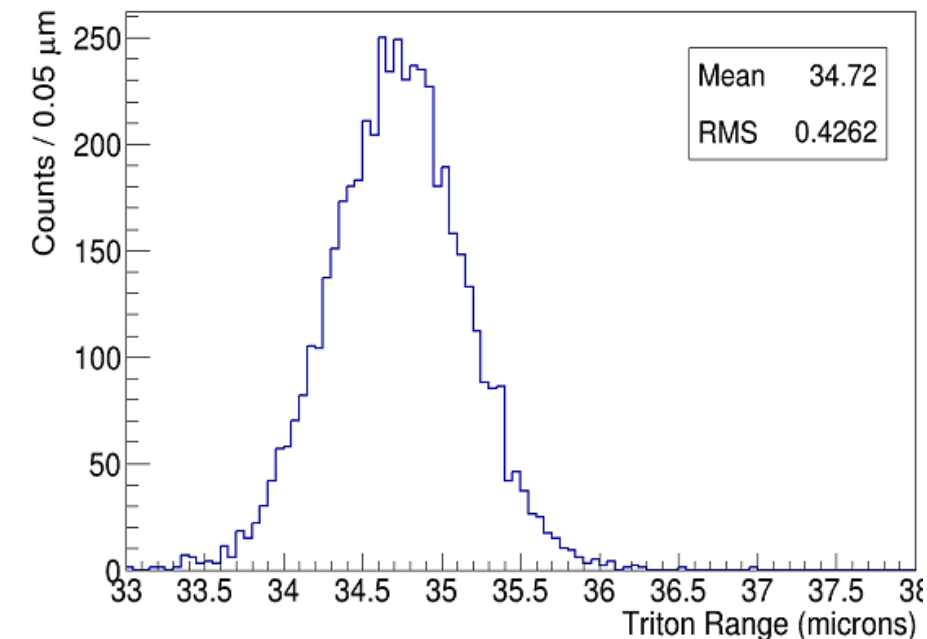
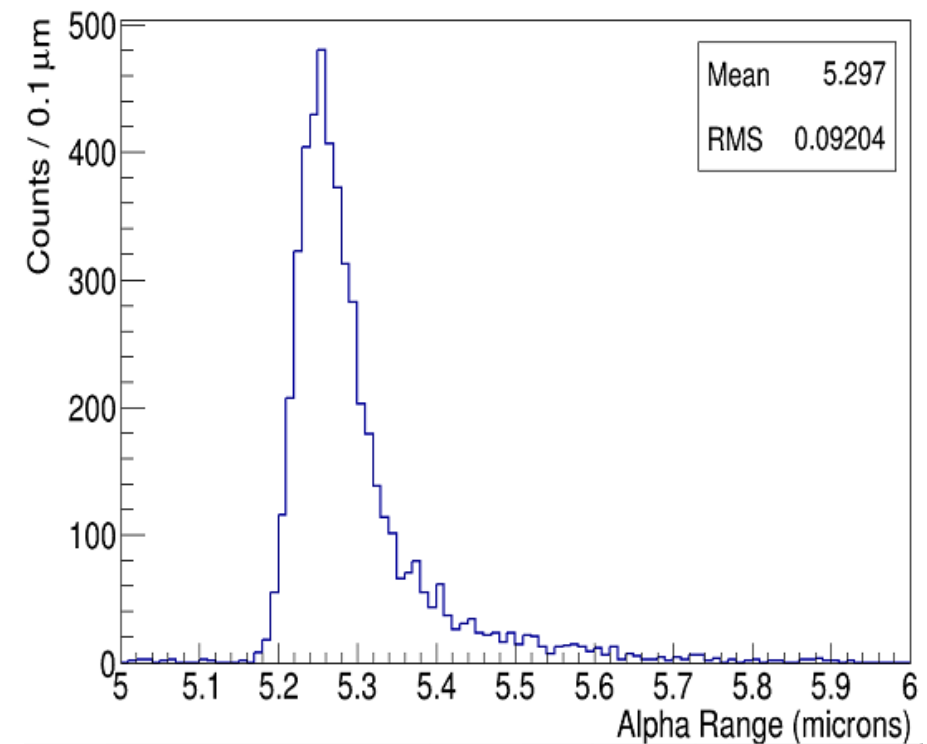

Waveforms

- Simulated waveforms of detector output
- Used to develop template fits

$$PSD = \frac{Q_L - Q_S}{Q_L}$$

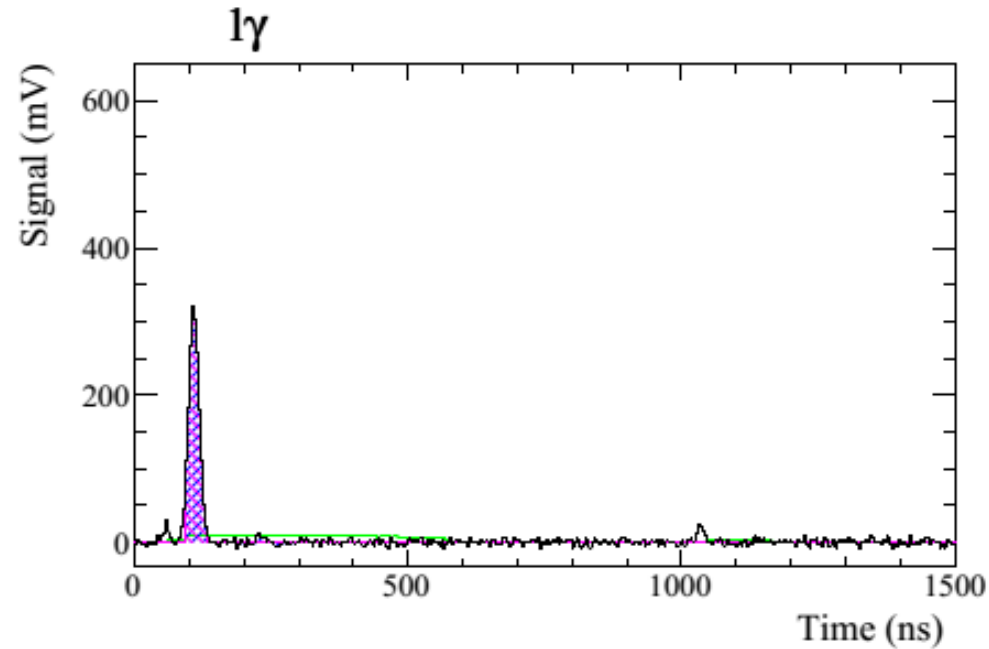
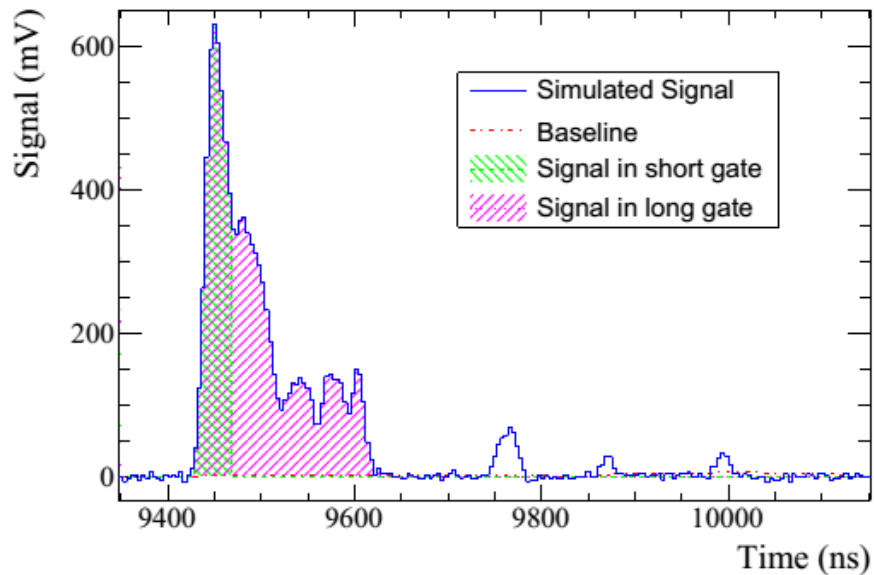
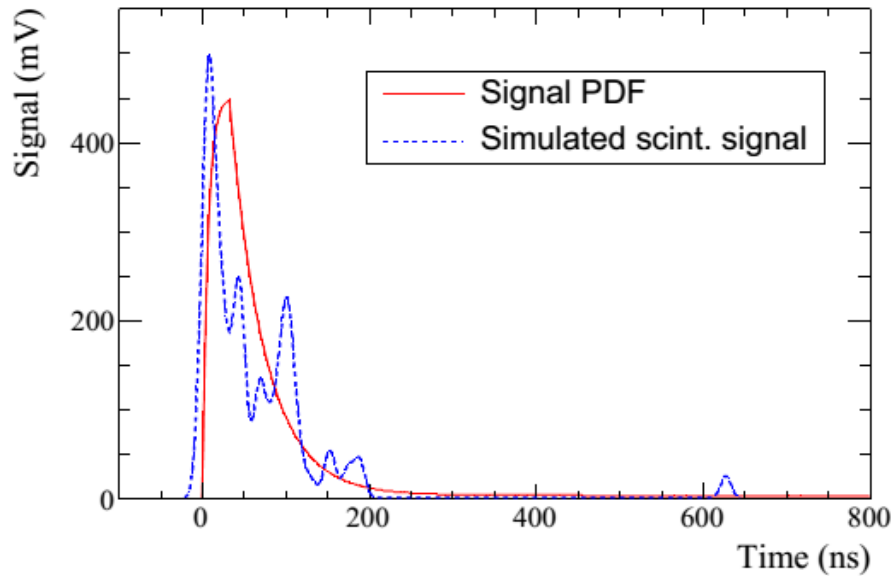

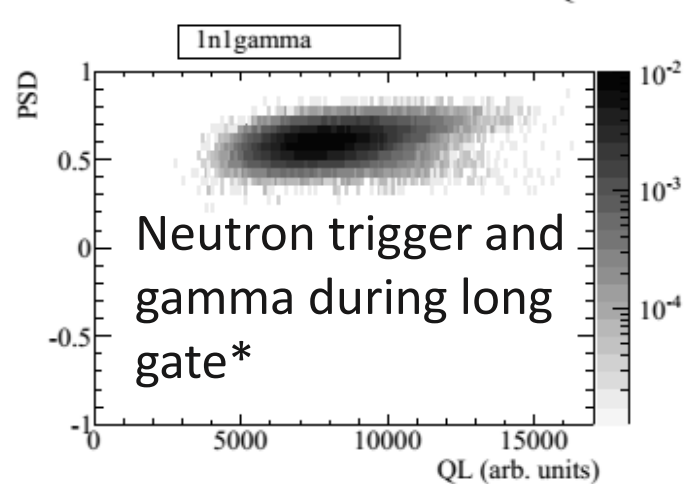
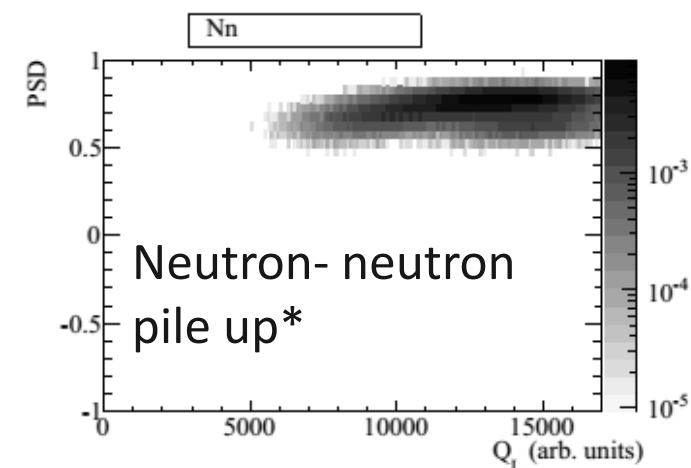
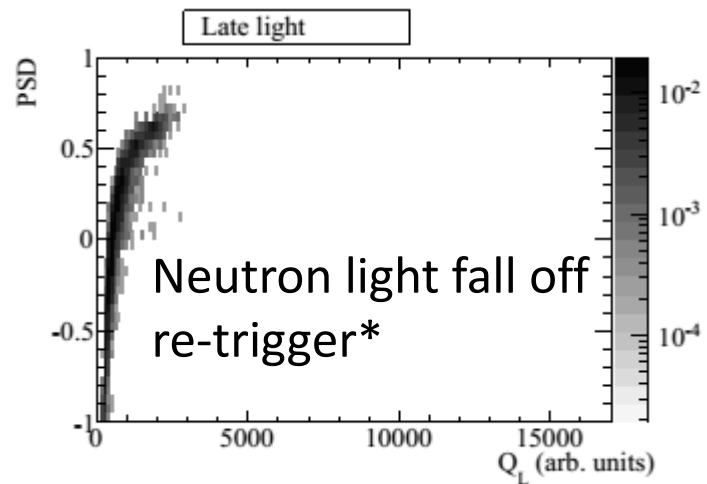
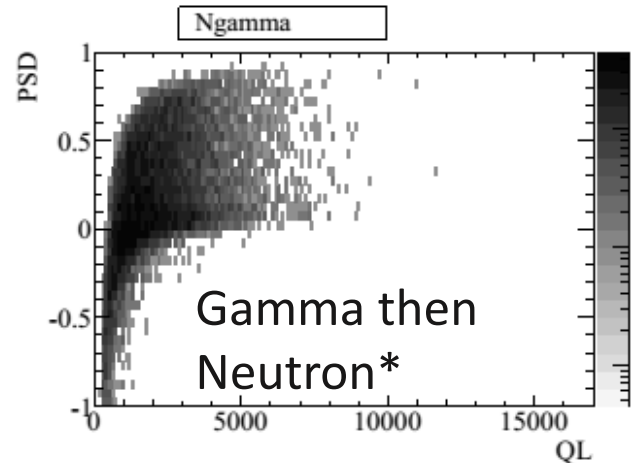
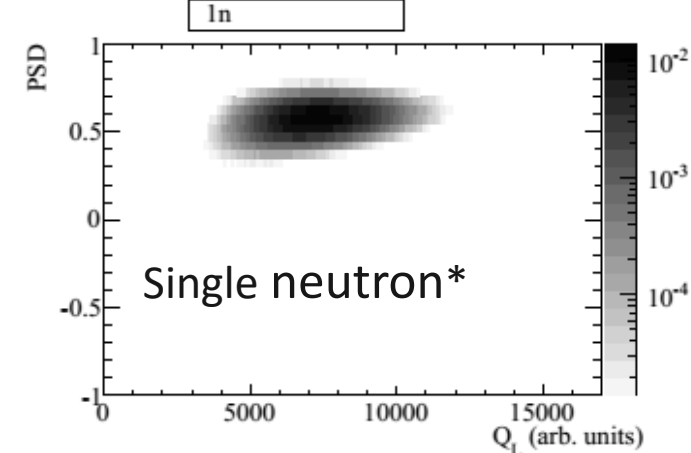

*Simulated events to account for data shape and to characterize detector

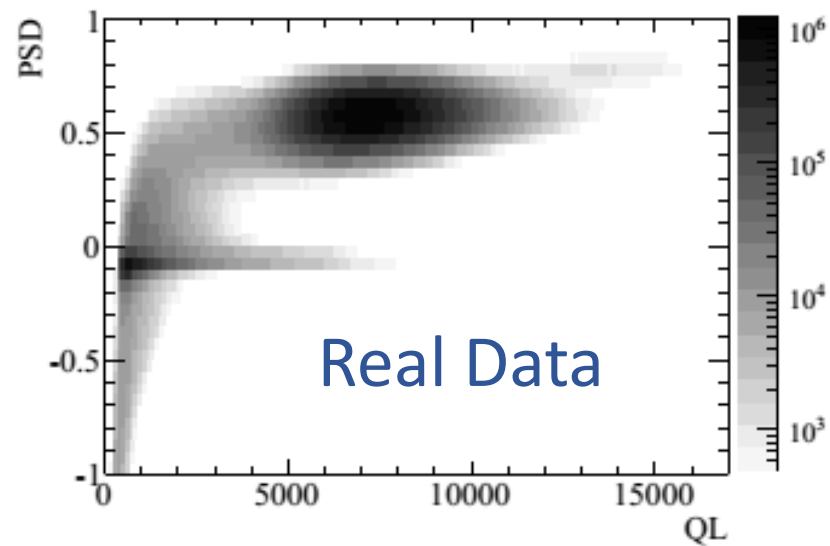
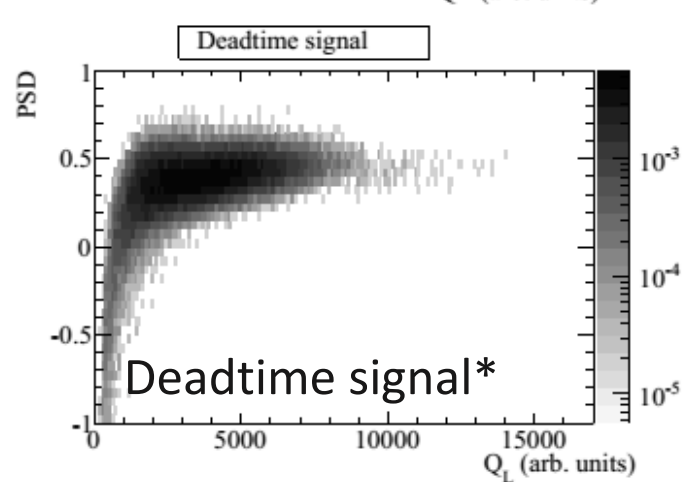
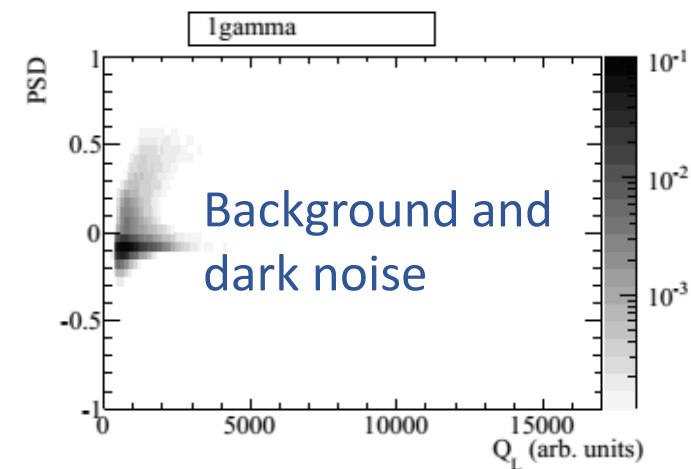

West 2: Li-6 vertical drop test

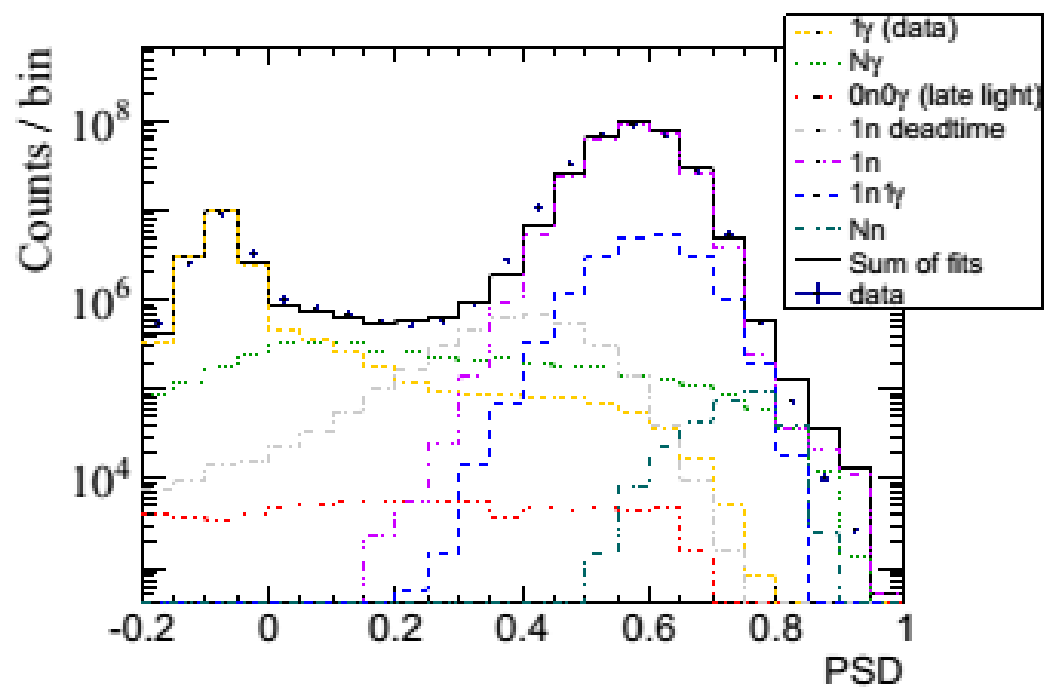
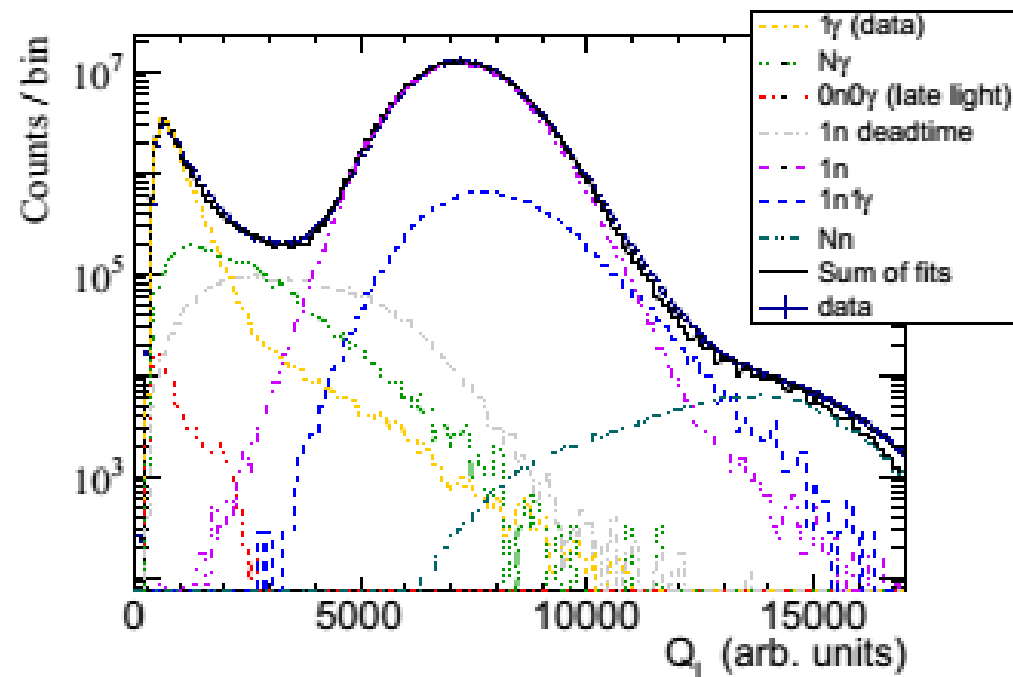
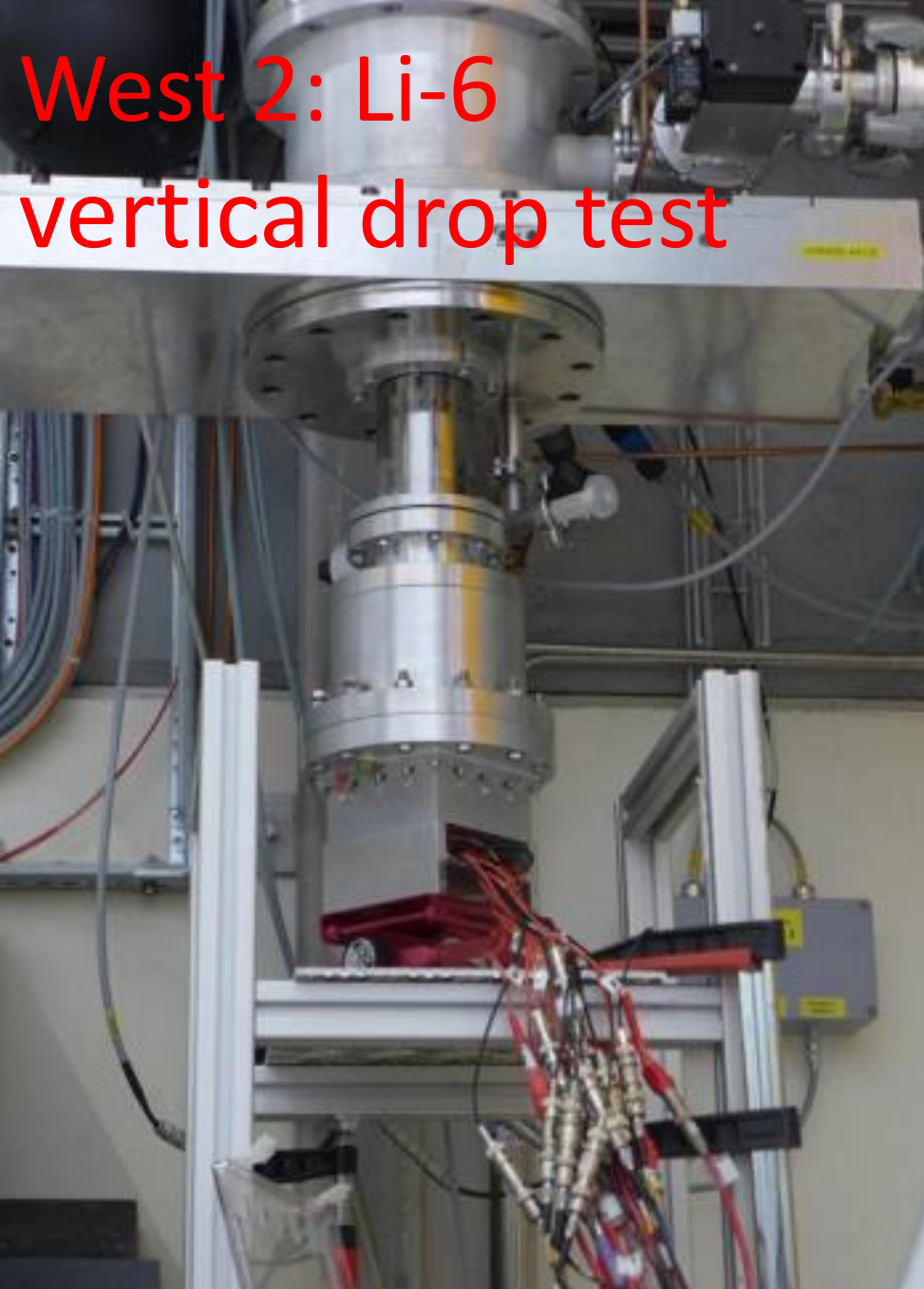



West-1: Horizontal Beamline

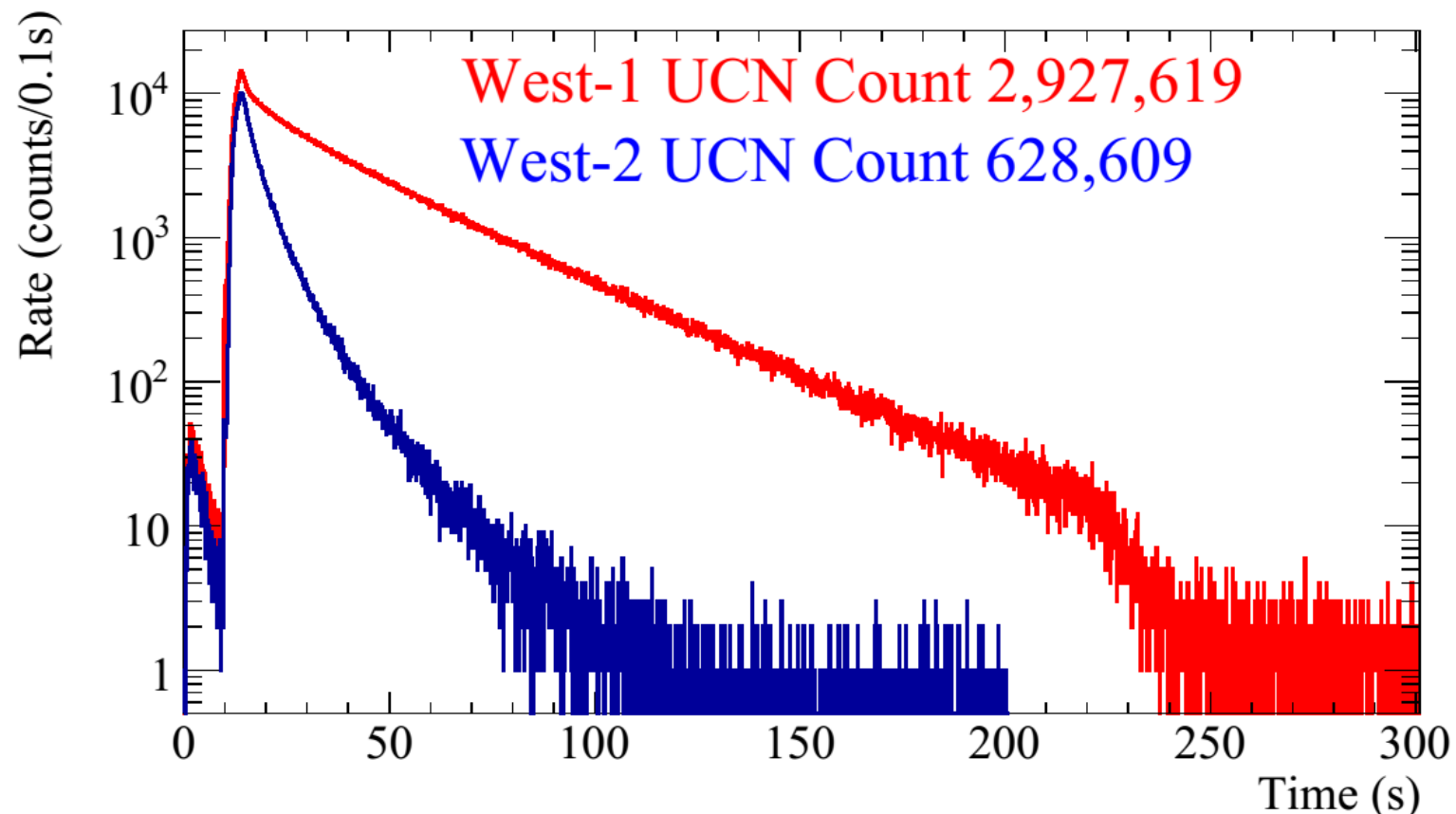

West-2: Comparison

Y-Splitter

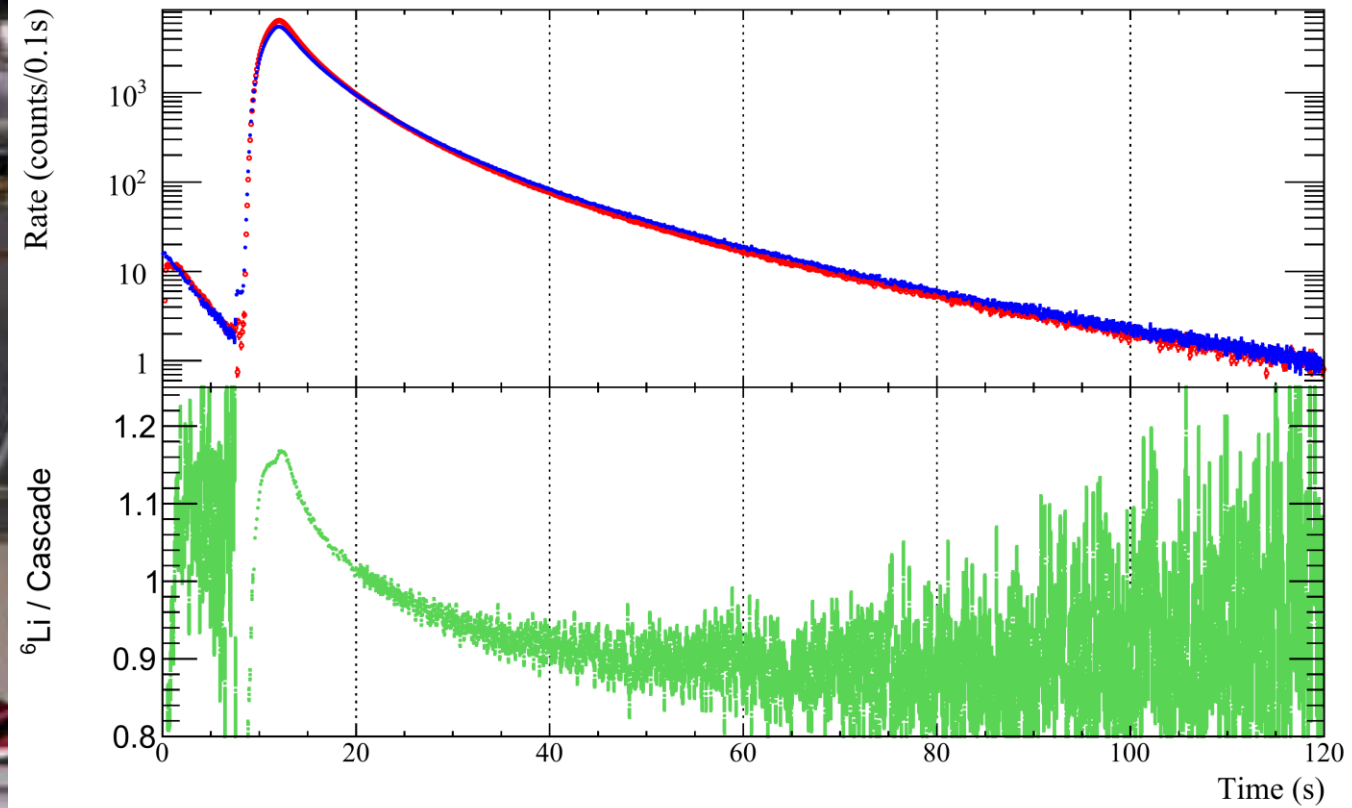
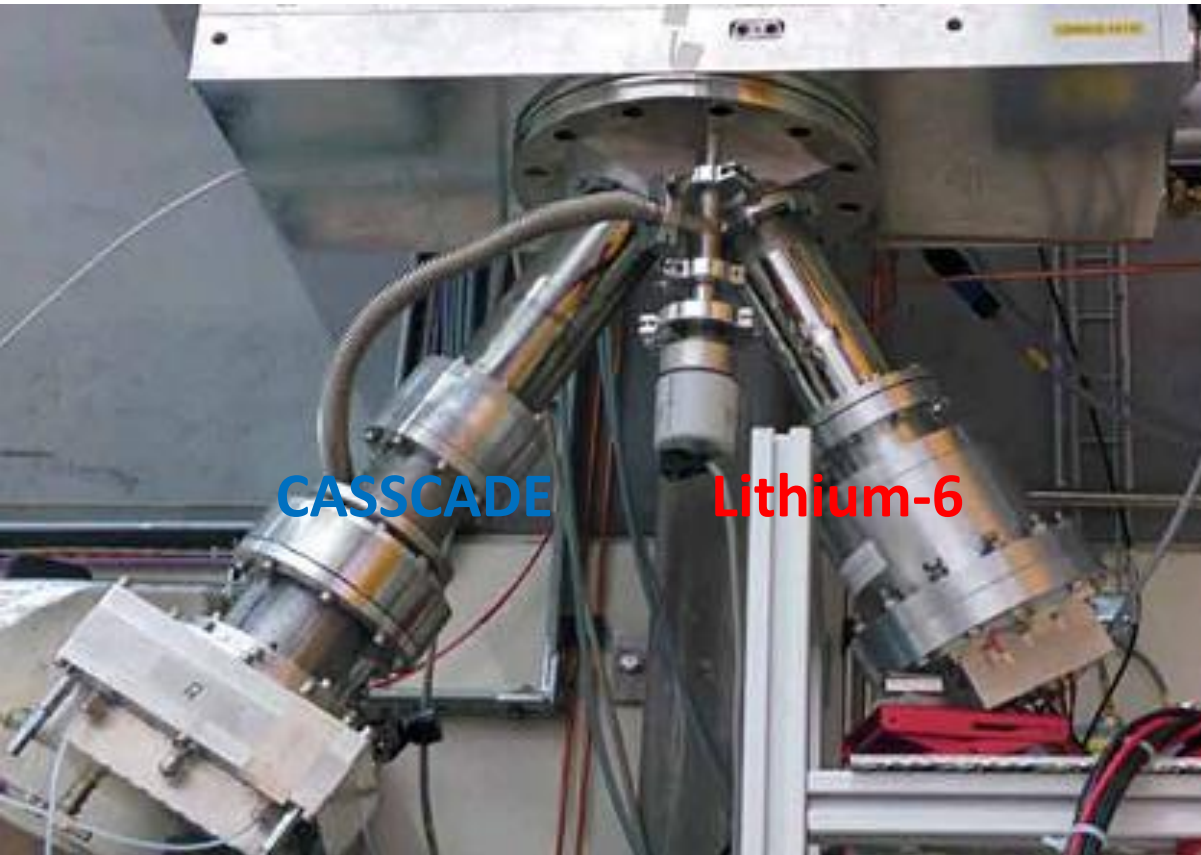

Conclusions on the paper

Testing and simulation lead to absolute efficiency estimate $89.7^{+1.3}_{-1.9}$ %

Background contamination of 0.3 ± 0.1 %.

Li-6 detector was shown to have stability of 0.06% level or better, and a variation between tiles less than 5%.

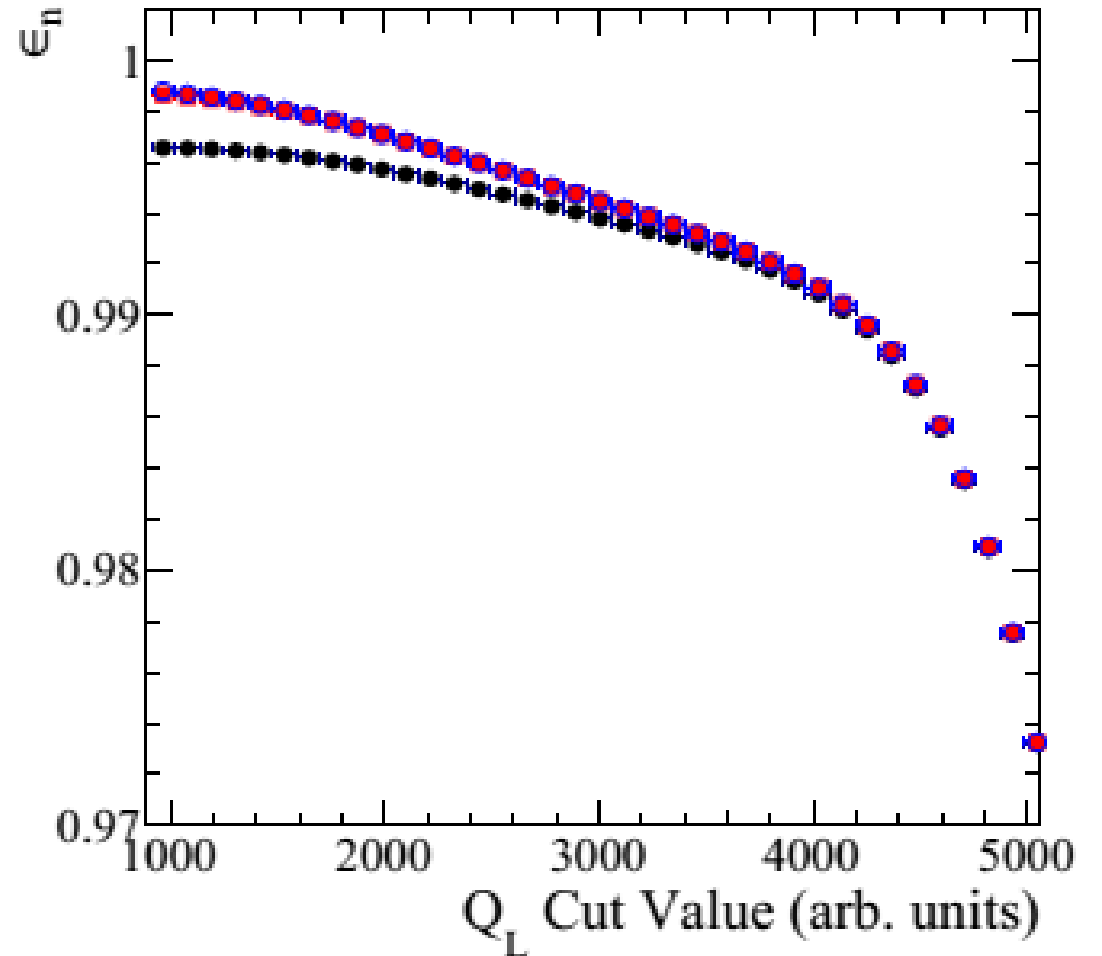

Magnetic Analyzer Foil

- Adiabatic Slow condition is required up to the foil, so depolarization and losses are kept to a minimum

$$v \, dB/dz \ll \omega B$$

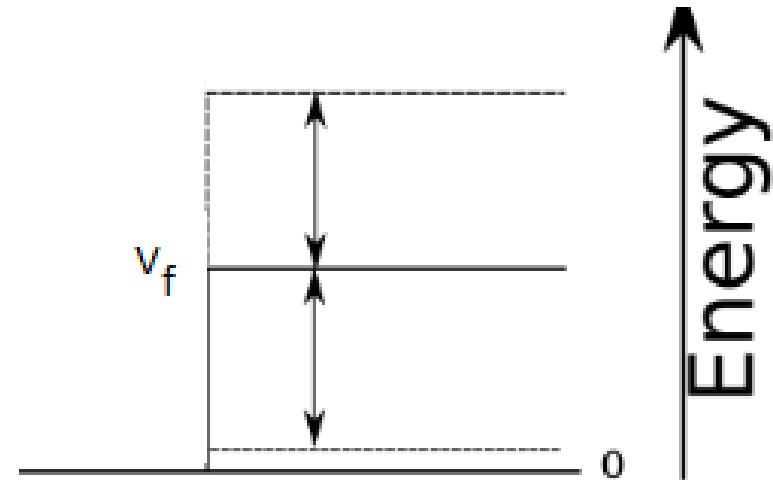

- A fermi potential can be modified in a magnetic field to only let one polarization through (see right)

$$V_{effective} = V_{Fermi} \pm \mu \cdot B$$

$$U = V_f^{iron} \pm |\mu_n| B_{sat} \sim 200 \pm 120 \text{ neV} \quad B_{sat} \sim 2 \text{ T}$$

Simulations OPERA FEA of magnetic foil

- Halbach array which is a array of neodymium magnets and a yoke
- Each arm is independently testable
- Each arm is more uniform in magnitude on the order of 2 T, than a H-yoke with either a long piece of iron foil or a double iron foil part

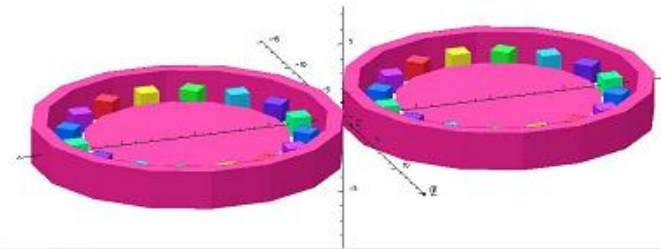

- Image left, pink iron (foil and yoke), other colours N52 Magnets

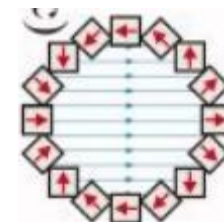
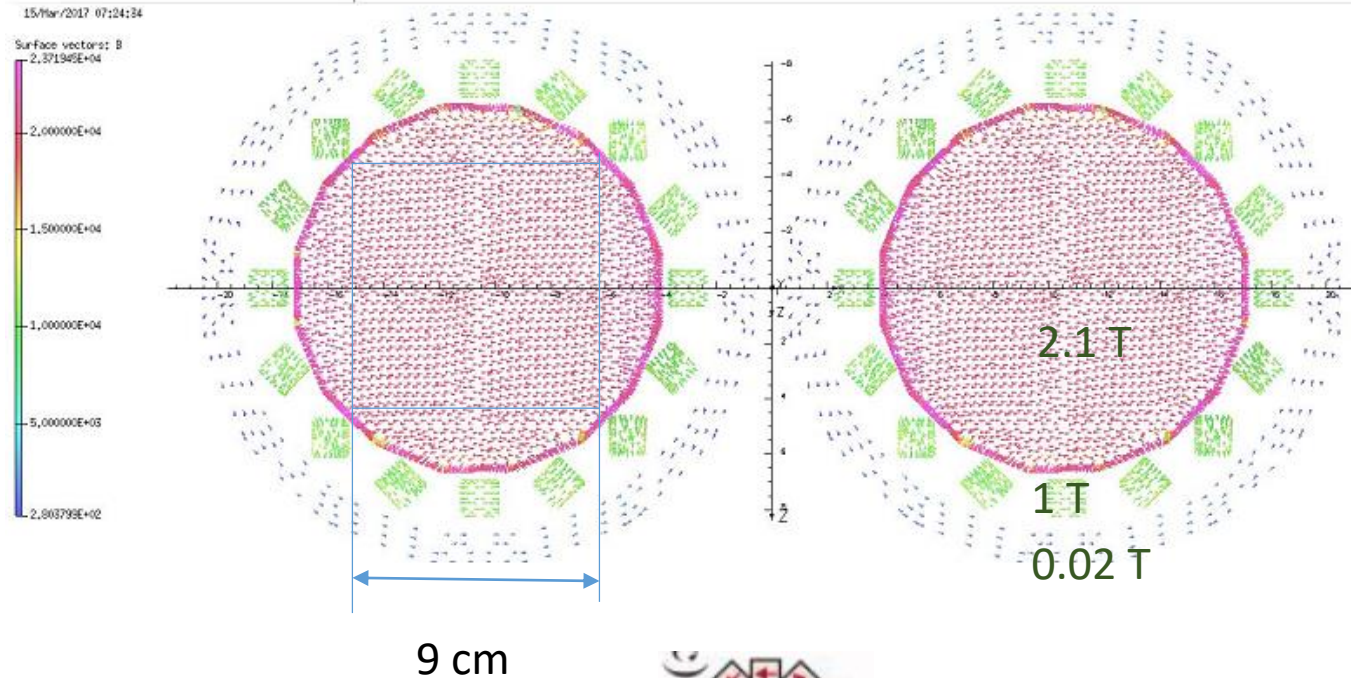

$$U = V_f^{iron} \pm |\mu_n| B_{sat} \sim 200 \pm 120 \text{ neV}$$

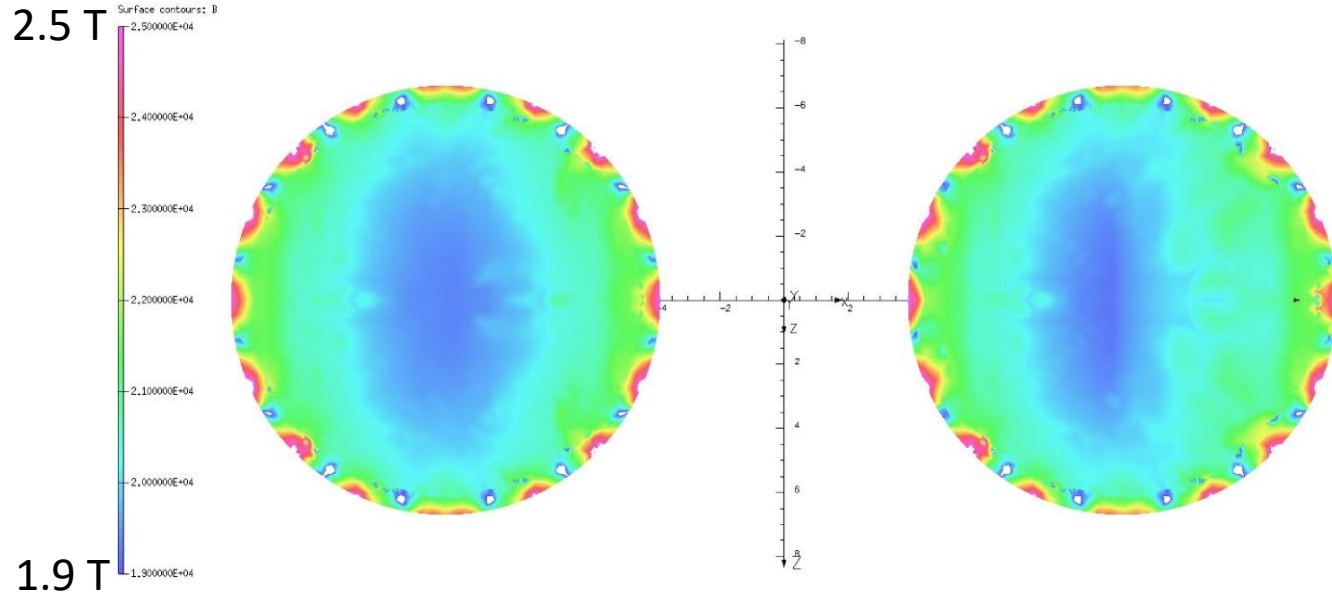
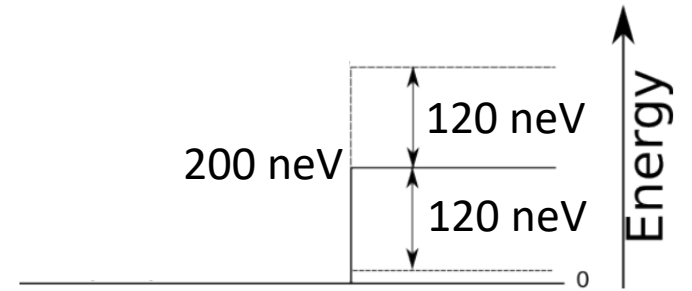

$$\gamma B \gg \hbar \nabla |B|/B$$

The adiabatic condition ensures that spin follows the field.

This condition is satisfied for both grey and black paths (right) to several orders of magnitude.

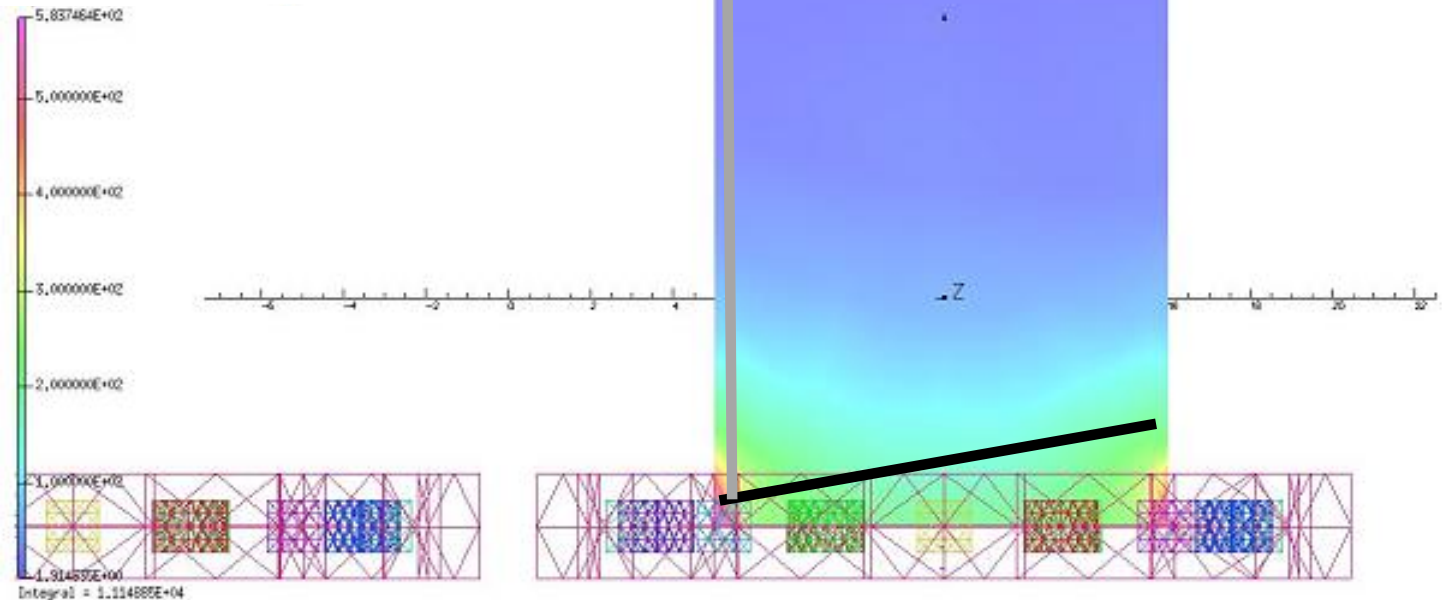

Adiabaticity condition

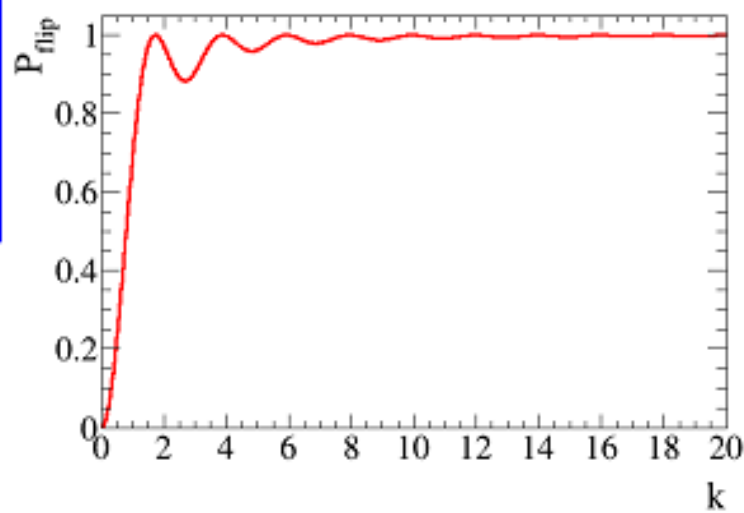

- Adiabaticity parameter, k :

$$k = \frac{\gamma_n B_1^2}{v_n dB_0/dz} \gg 1$$

- For RF field following \sim sine function get an spin flip probability:

$$P_{flip} = 1 - \frac{\sin^2(\pi \sqrt{1+k^2}/2)}{1+k^2}$$

NIM Phys. Res. A 384(23)
(1997) 451.

Adiabatic Fast Passage (AFP) parameters at 20 cm above Halbach foil

$B_0 = 0.27$ mT (in X dir.); $dB_0/dy = 1.72$ mT/m; $B_1 = 0.05$ mT (in Y dir.) @ ~ 50 kHz

$k = 1.83 \times 10^8 \text{ rad}/(\text{s.T}) (0.5 \times 10^{-4} \text{ T})^2 / (10 \text{ m/s} \times 0.00172 \text{ T/m}) = 26.6$

Spinflipper RF coil and shield

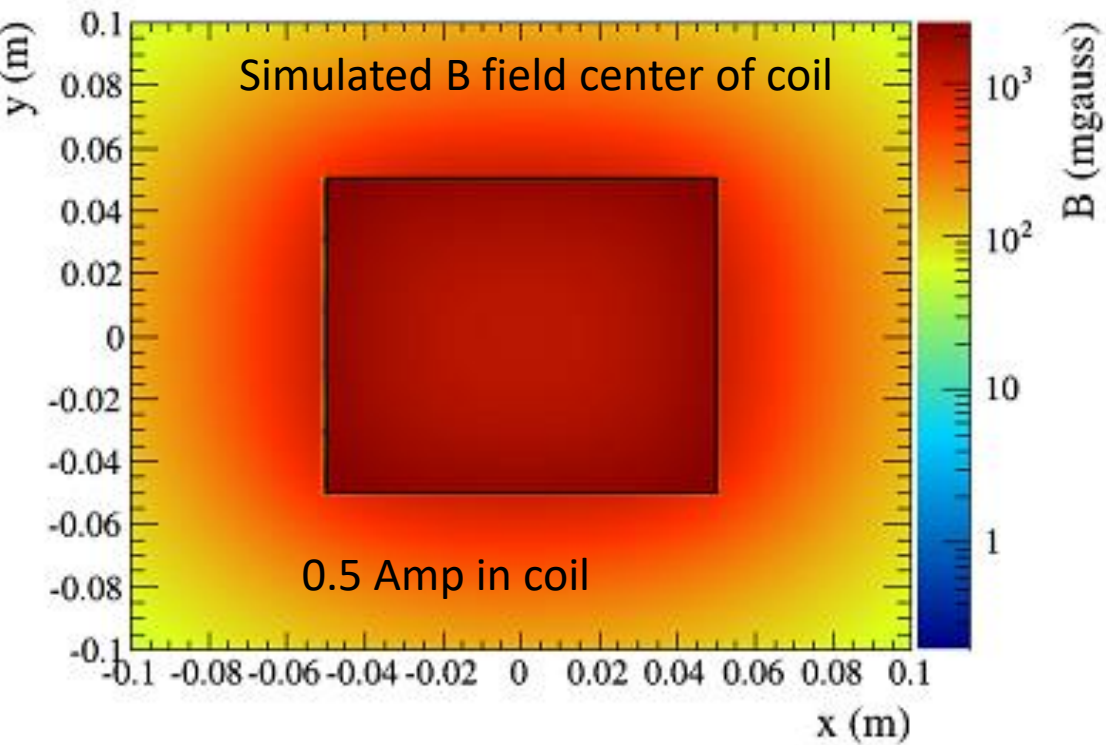

- Build from PLA using 3D printer – one piece

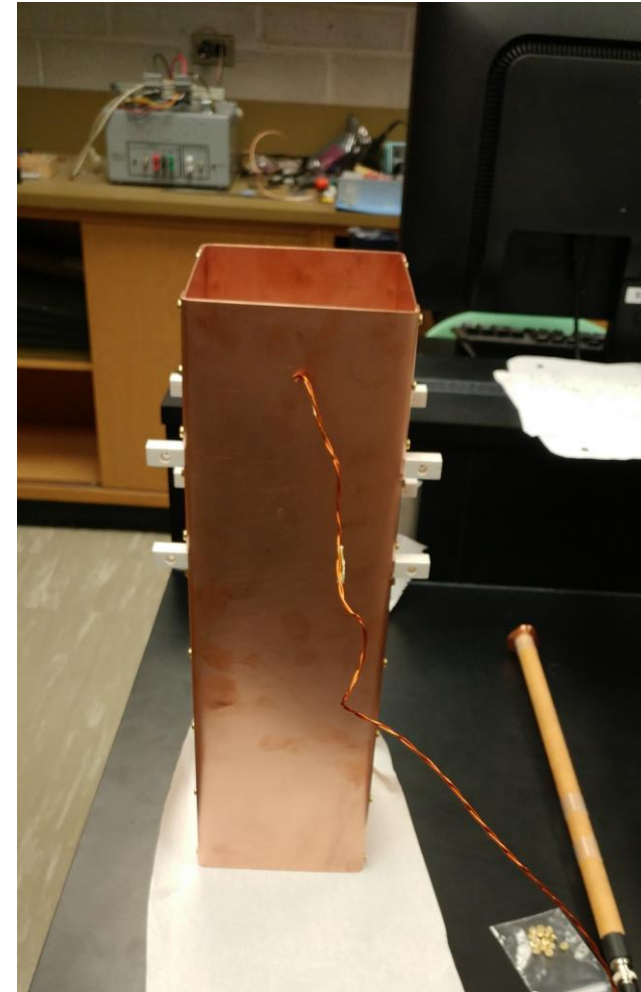
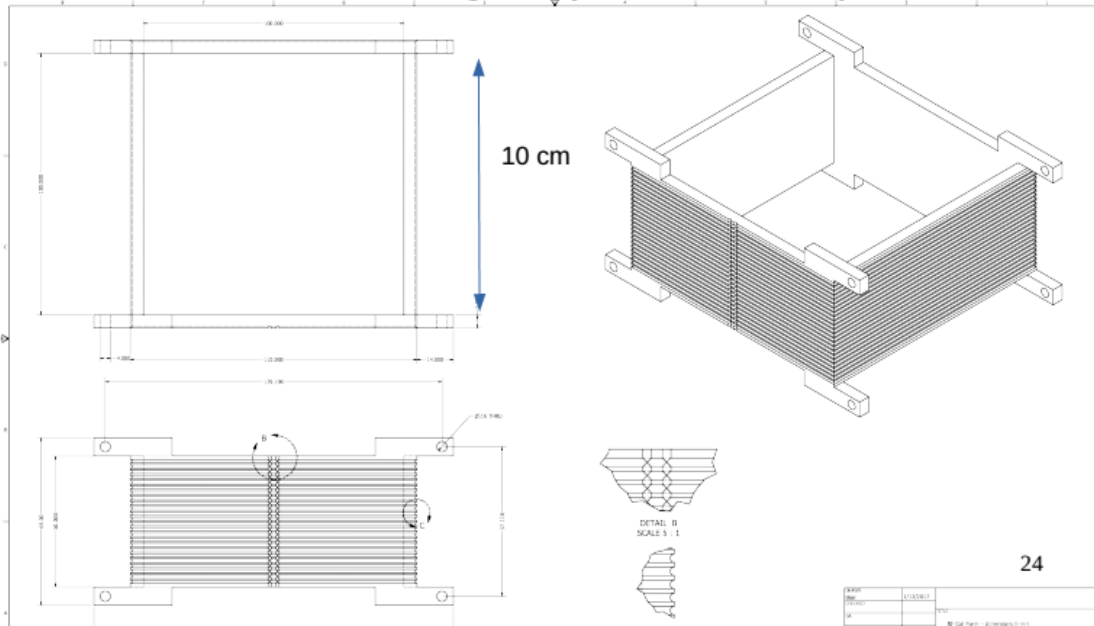

RF encased in copper
shielding

SSA GEANT4 Simulation Geometry

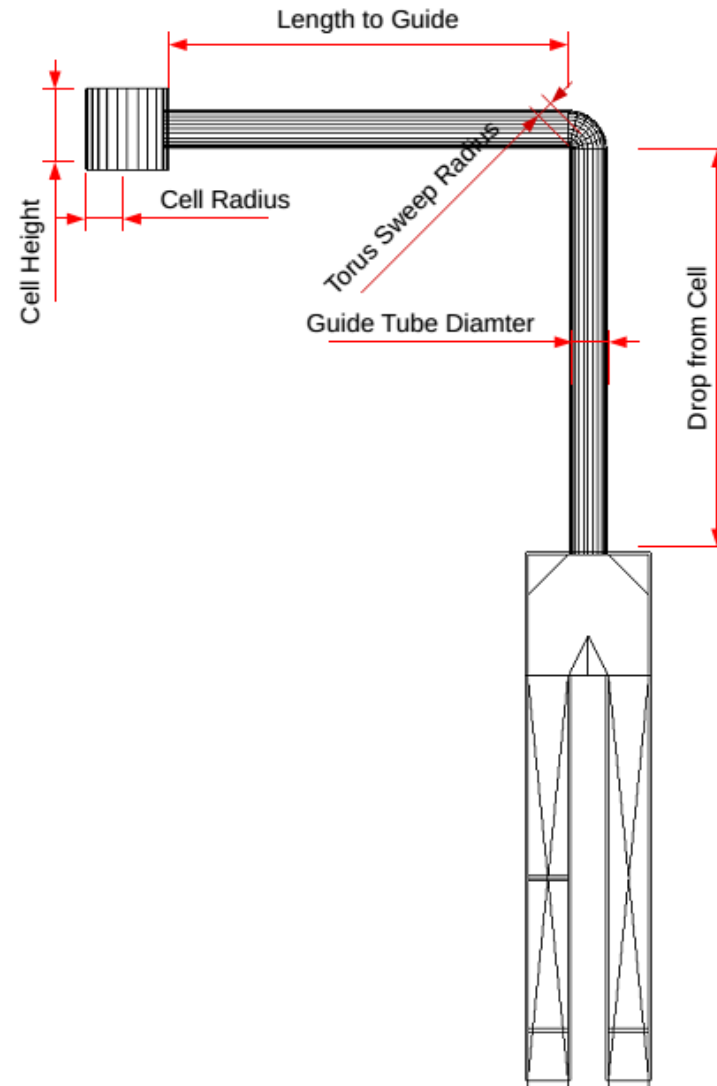
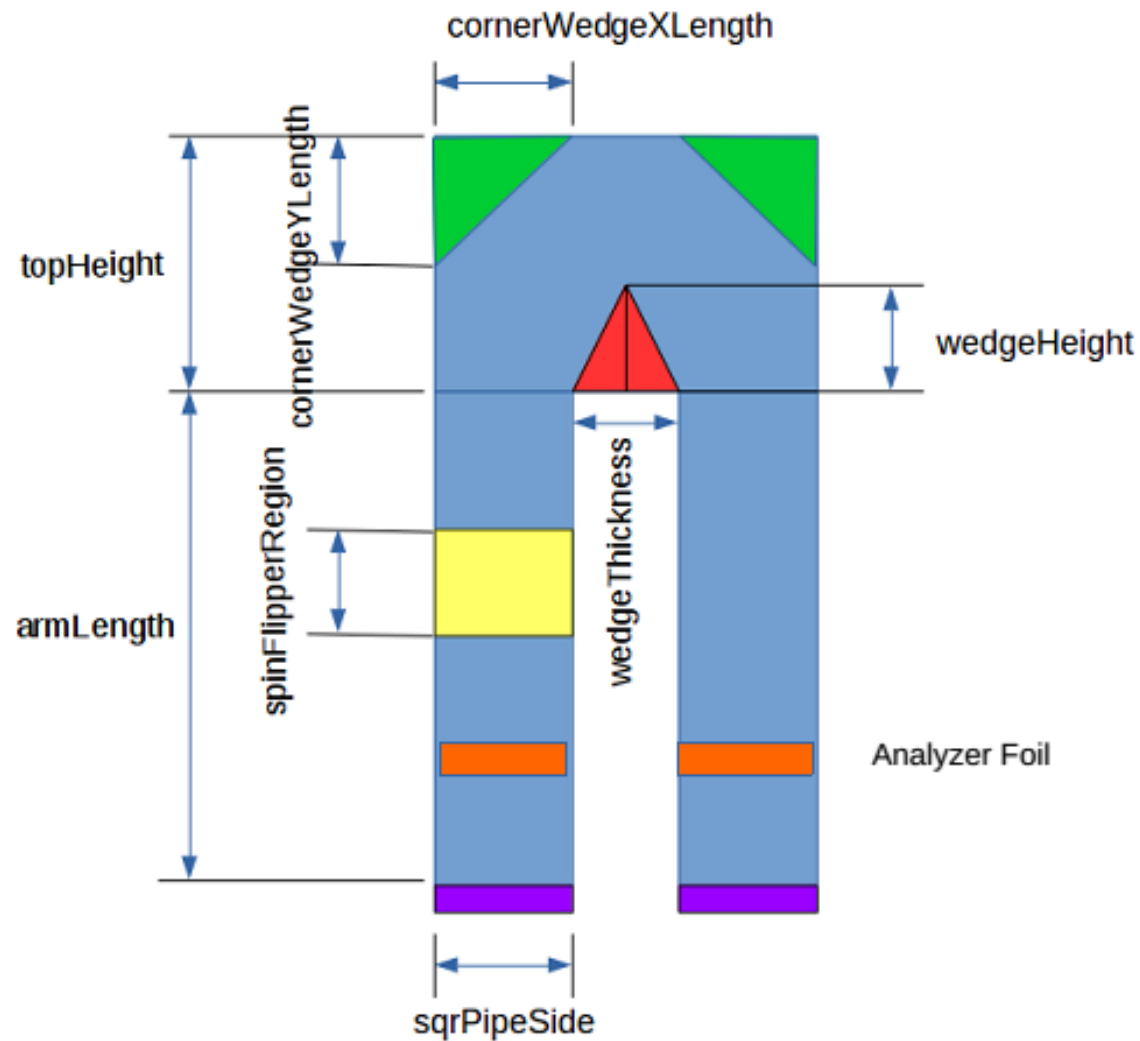

Conclusion of Talk

- Glass stack Li-6 fast rate detector was developed based on PSI's version and tested at PSI for use in the TRIUMF nEDM experiment with estimated absolute efficiency of $89.7 \pm (+1.3, -1.9) \%$
- Developing a version of the Simultaneous Spin Analyzer system similar to PSI.

Thank-you

Digitizer for fast DAQ

- V1720 Digitizer from CAEN
 - 8-channel waveform digitizer with pulse shape analysis on FPGA

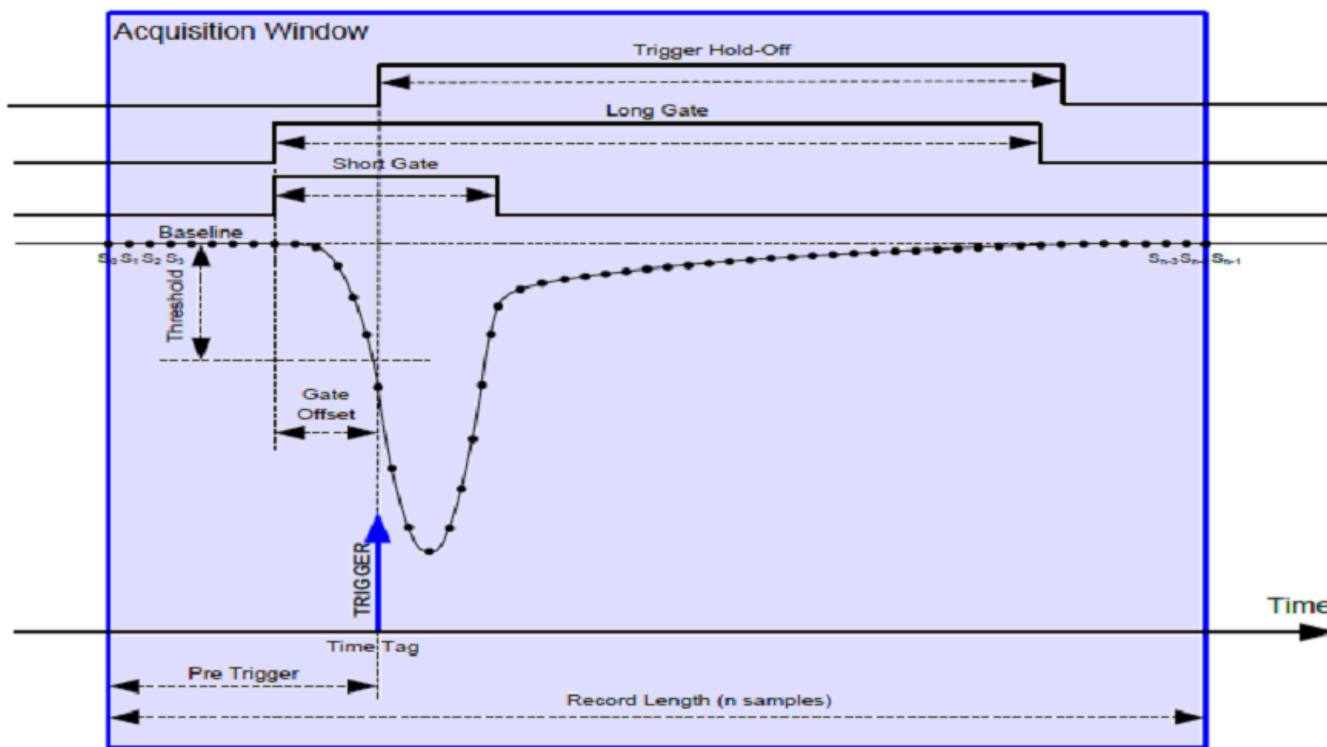

AFP

- Static gradient field H_0 + perpendicular RF H_1
- H_1 at Ramsey frequency @ center of ASF
- Need rate of change of H_0 field seen by neutron to be slower than Ramsey rotation

