

Accelerator Science and technology at TRIUMF

Oliver Kester

Associate Laboratory Director –
Accelerator Division

TRIUMF Science Week,
August 17, 2020

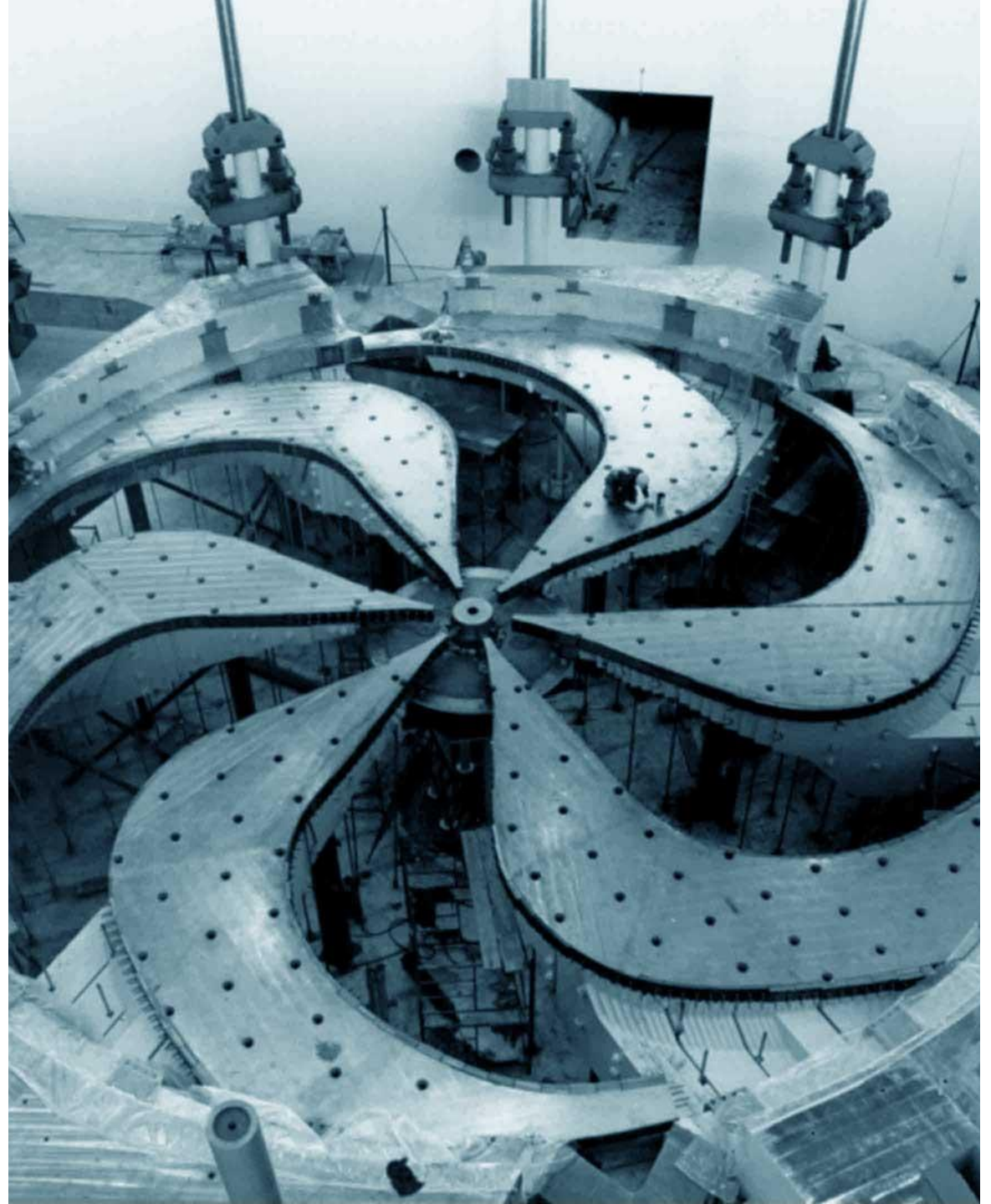



TRIUMF is Canada's
particle accelerator centre



TRIUMF has five decades of experience in building a rich particle accelerator infrastructure that nurtures cutting-edge research.

18↑
R

Accelerator Science and technology at TRIUMF

- does provide Canada with a world-class platform in
 - beam physics and instrumentation
 - secondary particle production, and
 - Superconducting RF (SRF) technologies.
- supports the high performance and availability of TRIUMF's accelerator complex, including new facilities such as ARIEL as well as international projects such as HL-LHC.

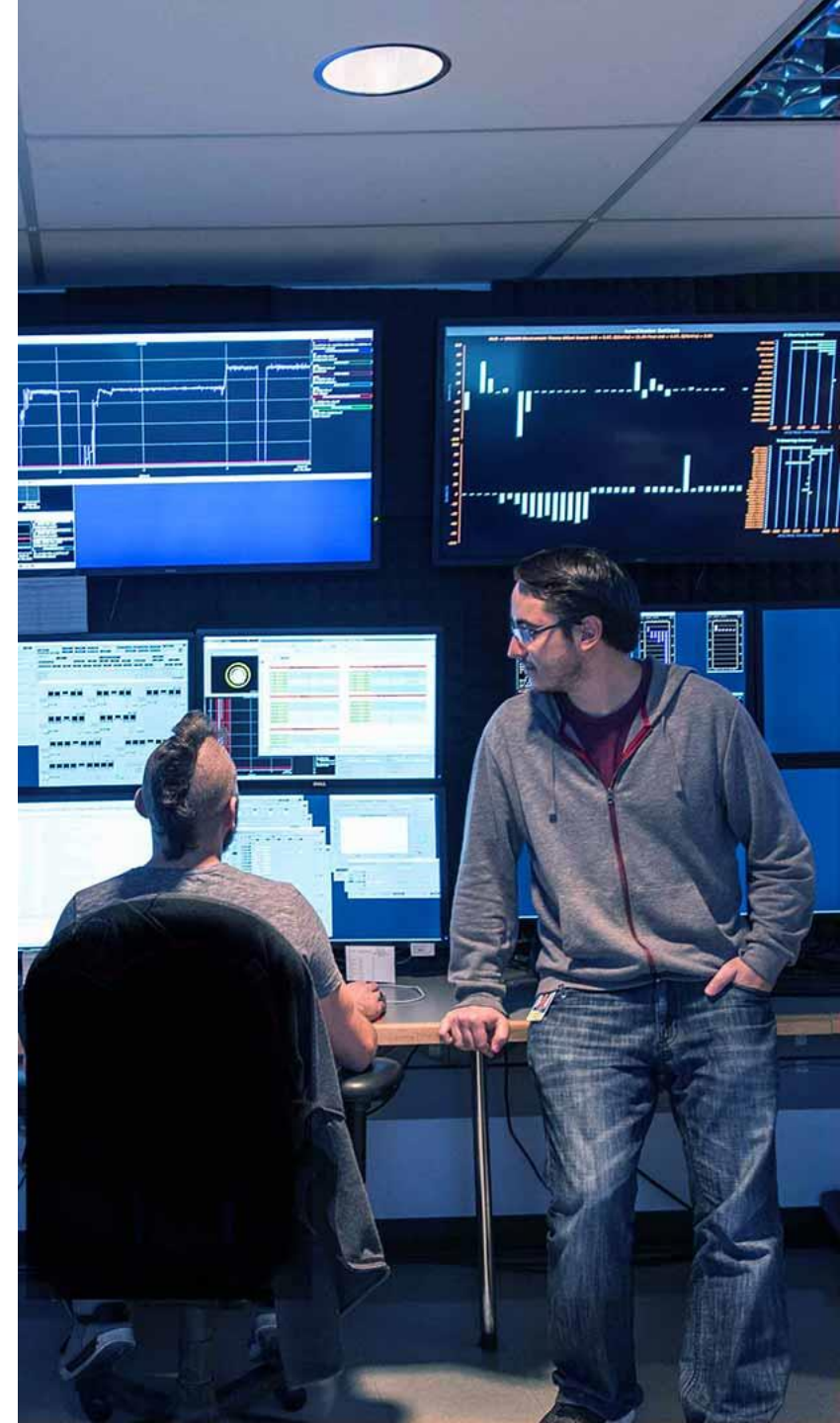

TRIUMF accelerator complex

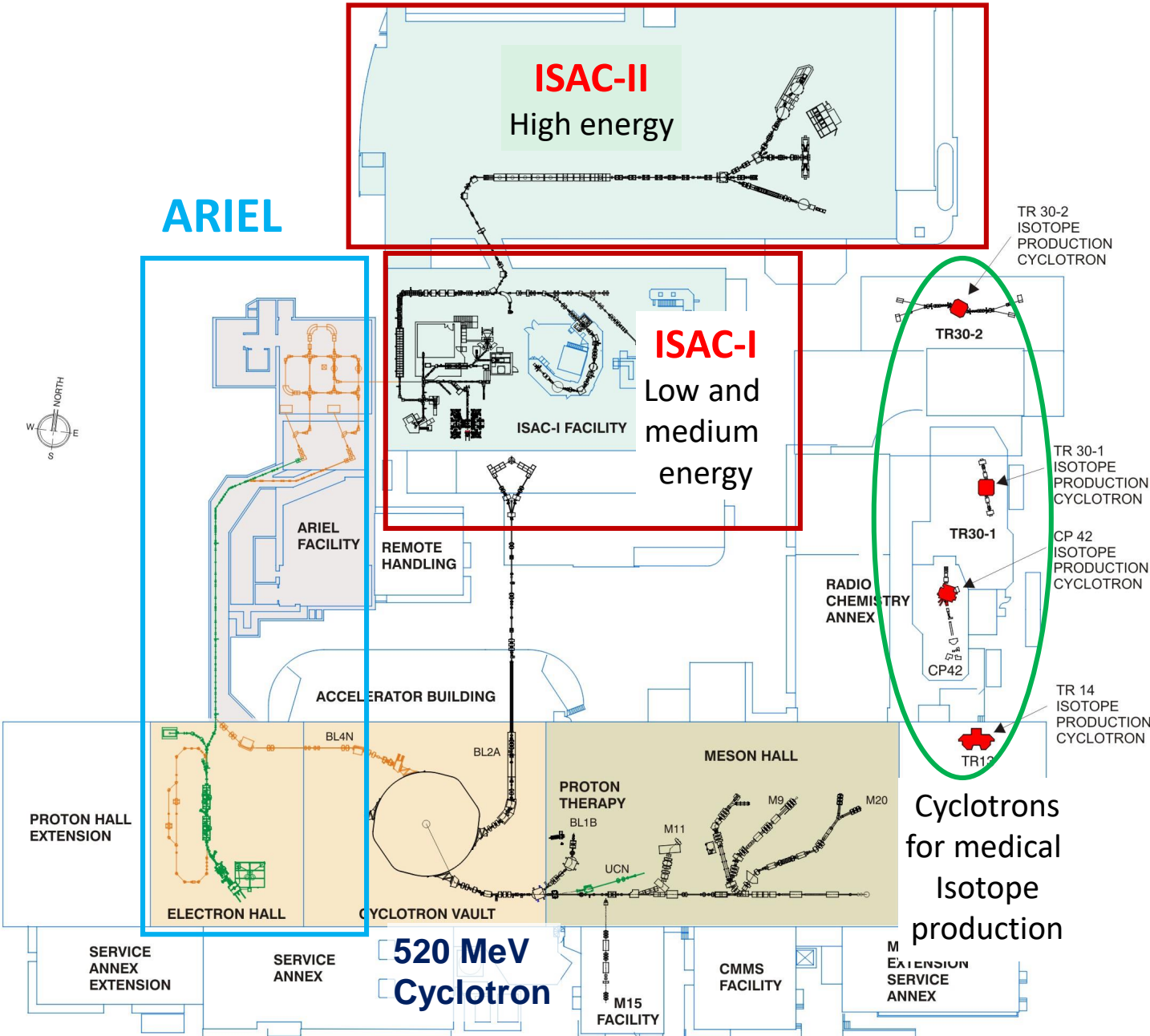

Primary beam driver:
Cyclotron, 520 MeV, H⁻
Produces rare isotopes, neutrons and muons!

Isotope Separator and Accelerator facility -
ISAC

Isotope Separator Online (ISOL) facility
ISAC-I: Normal conducting-linac, 0.15-1.8 MeV/u
ISAC-II: Superconducting-linac, 1.5-16.5 MeV/u

Advanced Rare Isotope Laboratory - **ARIEL**

Superconducting electron linac
30 MeV, 10 mA, cw

4 Cyclotrons for medical isotope production

Cyclotrons
for medical
Isotope
production

Uniqueness of TRIUMF's accelerator facility

- **520 MeV H⁻ cyclotron**

- Multiple high-power beams of different energies by stripping extraction
- Production of secondary particles - Rare Isotopes, Muons and Ultracold Neutrons

- **Isotope Separator and Accelerator facility – ISAC**

- ISOL facility that can receive up to 50 kW driver beam power (ISOLDE 2.8 kW!)
- World's best and most versatile post accelerator

ISAC I and ISAC II Linacs

- For acceleration of elements in the medium mass range
→ **Charge State booster (ion source)**

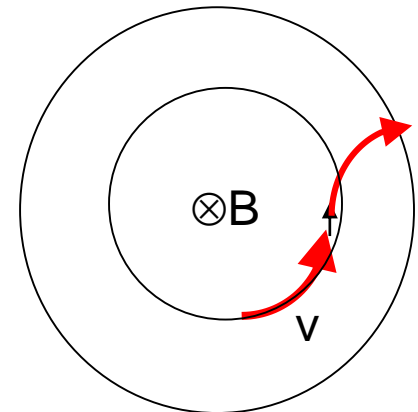
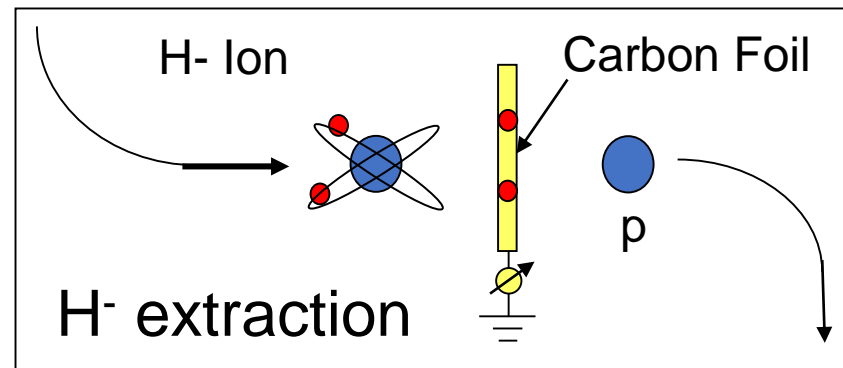
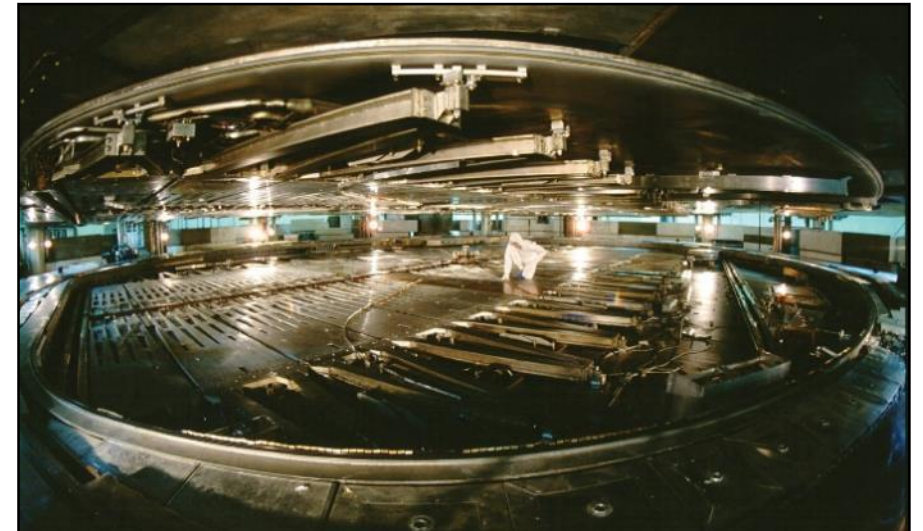

Adding new capabilities - ARIEL

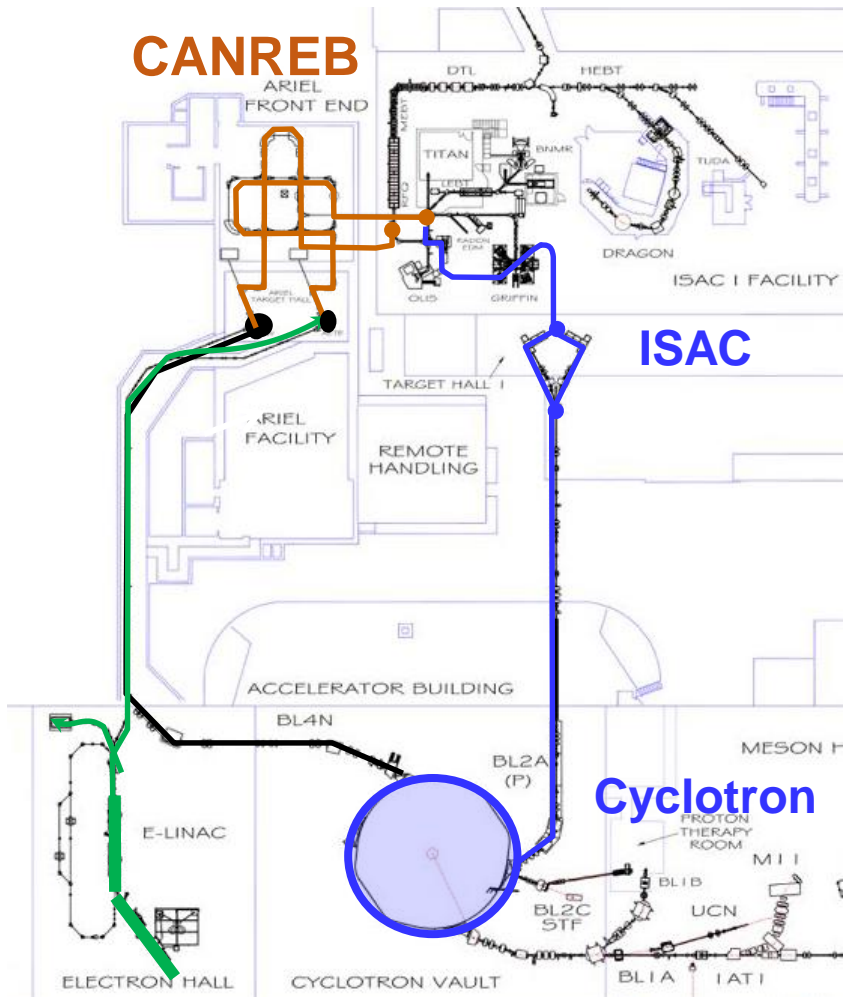

e-linac – 30MeV

- A 30 MeV superconducting electron linac
300 kW beam power cw, highest power in this energy range
- Two new high-power rare isotope target stations
 - New 100 kW convertor target station
 - 50 kW proton target station (with symbiotic target for medical isotope production)
 - It will triple ISAC's present rare isotope capabilities.
- Unique beam preparation and transport system (CANadian Rare isotope facility with Electron Beam ion source (EBIS) - CANREB)
 - High resolution separator
 - Beam preparation with gas filled Radio Frequency Quadrupole and EBIS



Keeping the TRIUMF accelerators at the leading edge

- Mitigation of risks for operation at high performance guides our project priority.
- Accelerator science supports the high performance and availability of TRIUMF's accelerator complex, with new developments and technologies.



Performance and operation risk mitigation – refurbishment program in the five year plan 2020-2025

- **520 MeV Cyclotron refurbishment**
 - Critical systems: Cyclotron RF-system, control system, vacuum system
 - H- injection beam line and ion source terminal
- **Proton beam line refurbishment**
 - BL1A power supplies
 - BL1A refurbishment (optic elements, diagnostic, vacuum)
 - Remote handling infrastructure
- **ISAC refurbishment (including probes for quantum materials)**
 - Critical systems: Target hall infrastructure and target modules
 - ISAC Linac RF-systems (ISAC20 → ageing equipment)
 - RIB delivery improvements (OLIS, RF-booster, diagnostics)
 - TRIUMF Resonance Laser Ion Source upgrade
- **TRIUMF Control Centre (TCC)**

- In the past 5YP, we installed a new Main Magnet Power Supply and exchanged the old one, which was operational for 45 years!
- Other cyclotron systems identified:
Control System, cryo-system for vacuum pumping, injection beam line, High Power Radio Frequency
→ towards reduction of beam losses

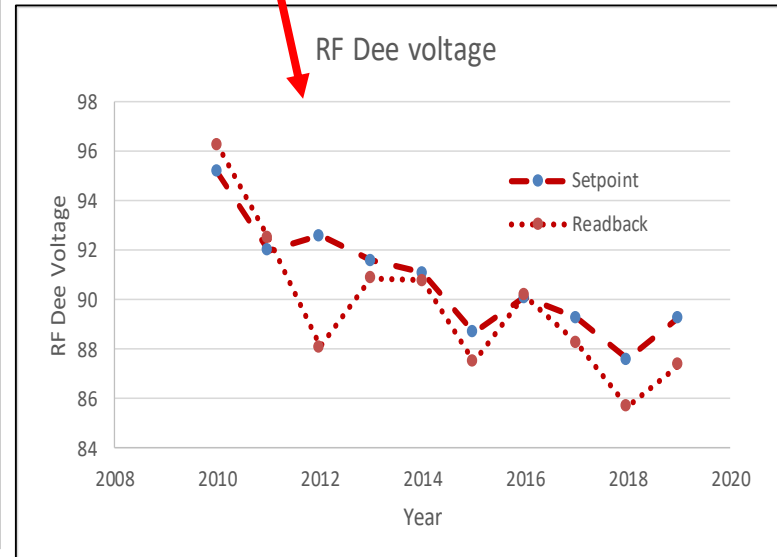
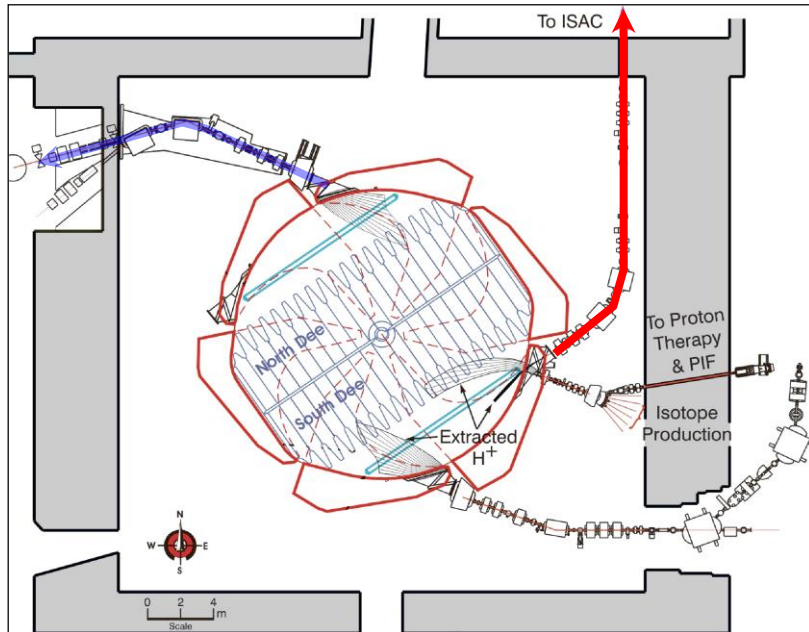

Proton beam lines refurbishment – BL1A

- In total there are 29 powers supplies, all of them have been in operation for more than 40 years
- Beam physics determines beam line configuration
 - New diagnostics, new collimation
 - Refurbishment of highly activated quadrupoles
- Remote handling tools and technology and infrastructure upgrade

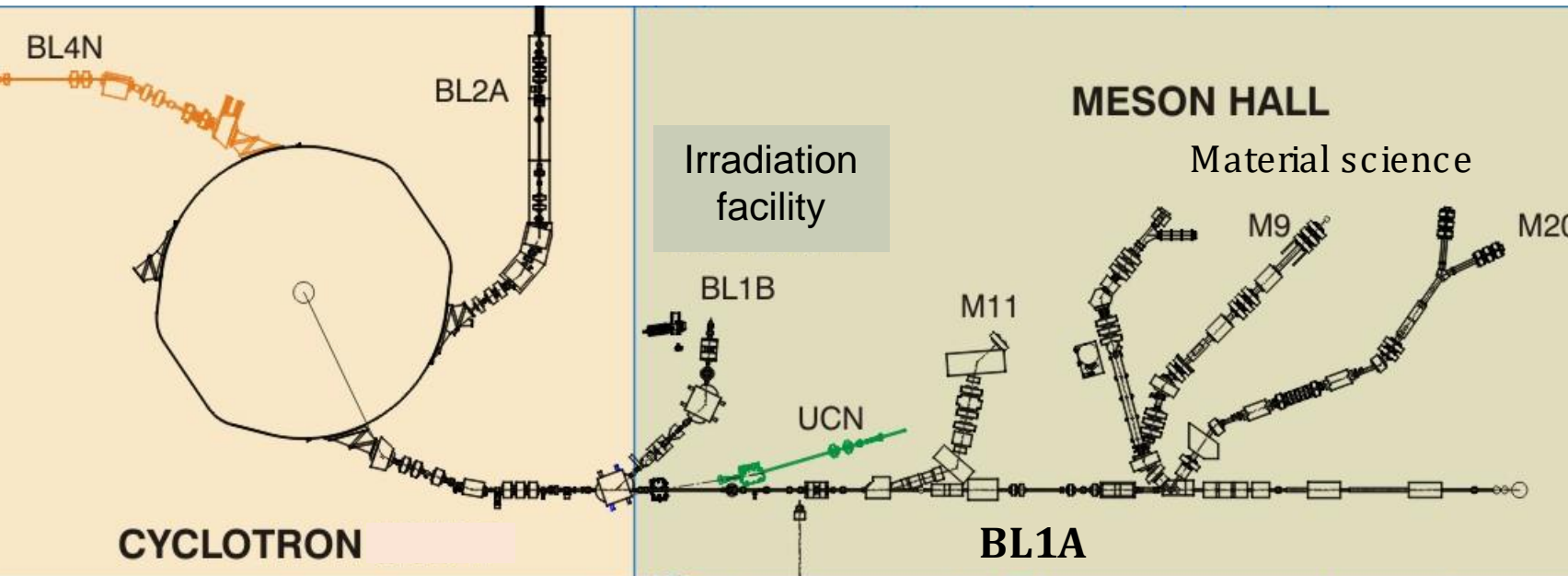
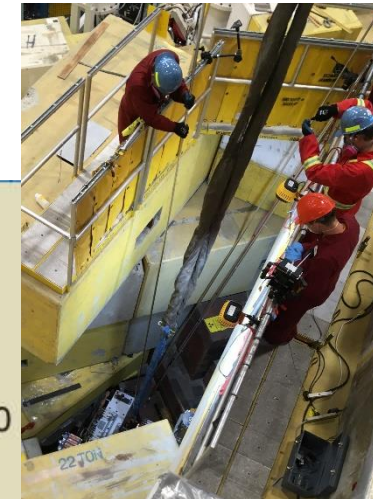

ISAC refurbishment

- ISAC-Target Module (TM) refurbishment and preparation for a new TM
 - Redesign of source and service trays to mitigate high voltage issues (65kV offline)
 - Installation of new source and service trays first at TM3
- Laser ion sources upgrade
 - reduce non resonant ionization of elements and reduce operation complexity

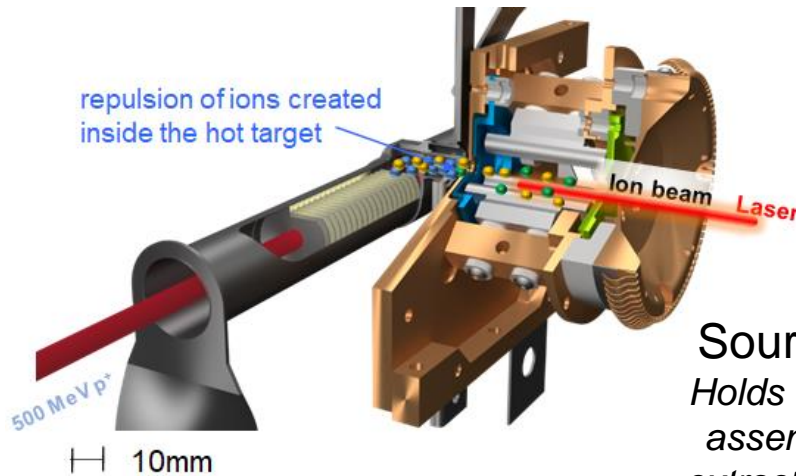
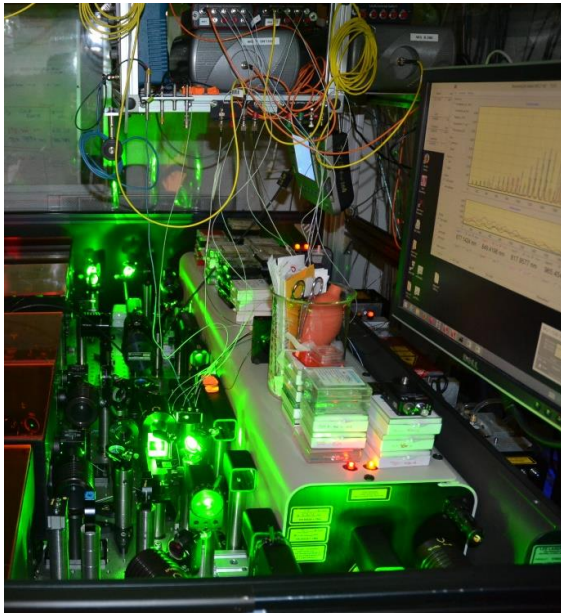

Service tray
Delivers all HV services from the module cap to the source tray

Source tray
Holds the target assembly and extraction optics

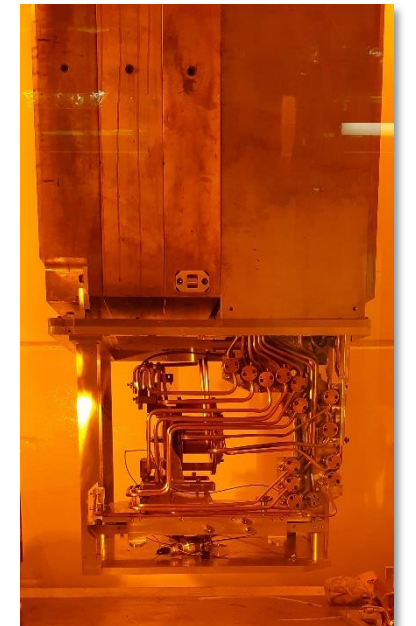
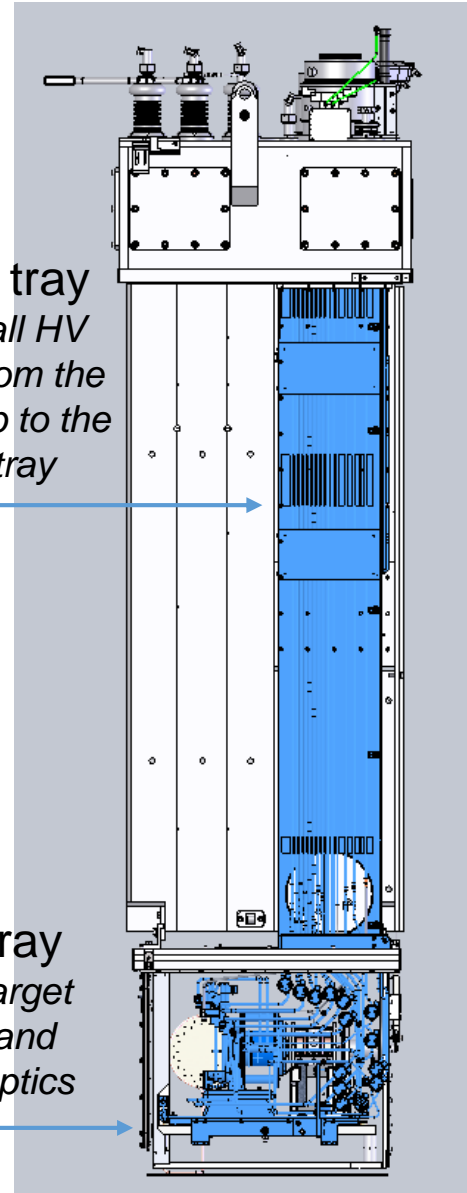

TRIUMF Control Center (TCC)

- Currently Rare Isotope Beam and Driver operation take place from two different Control Rooms located at opposite ends of the site.
→ not sustainable in the ARIEL operation era with three RIB beams in parallel
- A TRIUMF Control Center (TCC) will host the OPERATIONS group responsible for all TRIUMF accelerator systems, their associated targets and beamlines.
- Reduce cultural differences between operations groups and build common High-Level Application (HLA) tools for beam handling.



The Accelerator research program

Accelerator Science at TRIUMF does focus on three major platforms

- Beam Physics
- Secondary particle production
- SRF technologies

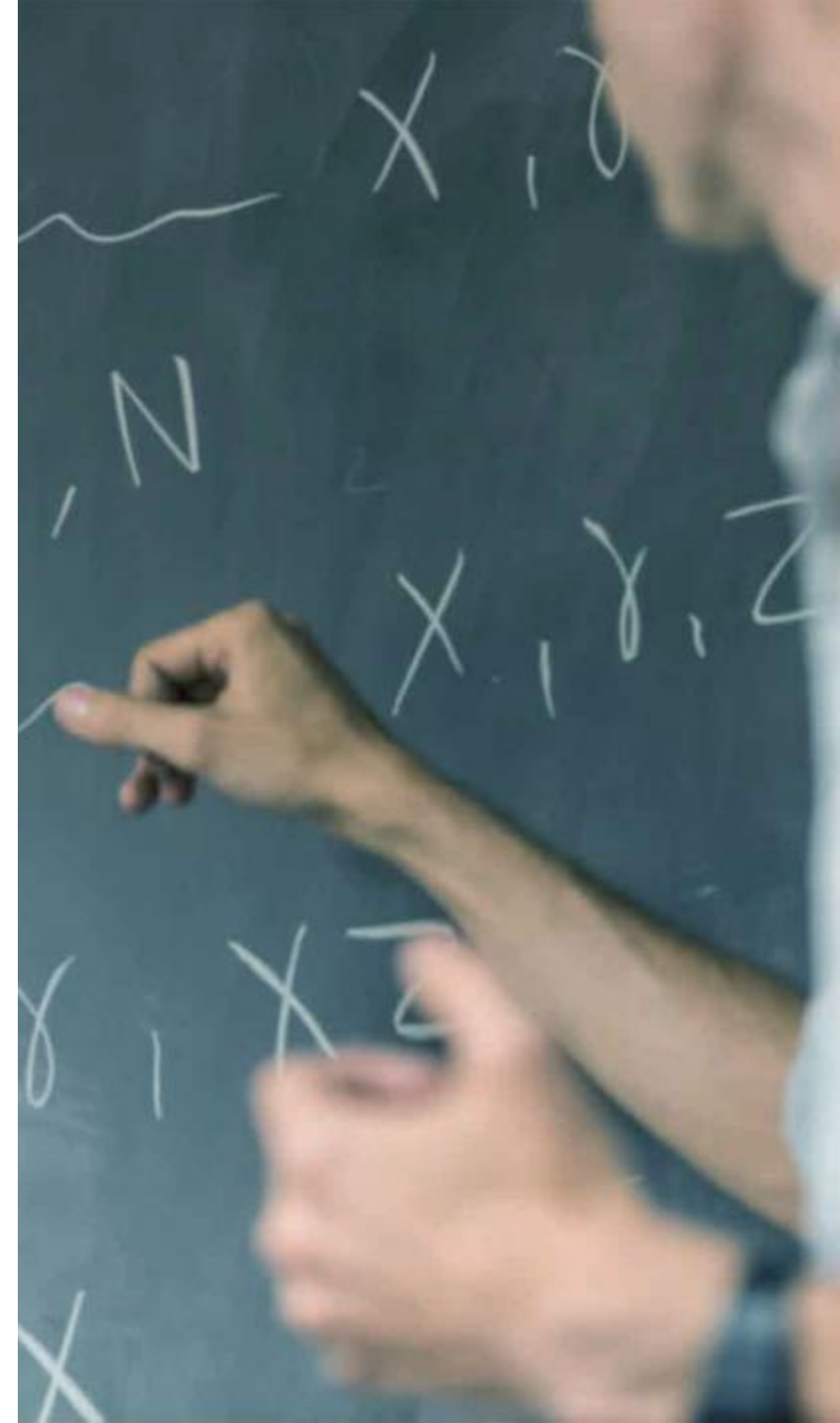

- Space charge dominated beams modelling
 - Reduction of beam losses and therewith reduced activation → less dose for maintenance personnel
 - In the future higher beam intensity in the H- cyclotron will be possible (possible application in medical cyclotrons)
 - High power beams in the ARIEL electron linac
- Develop a better understanding of ion sources, beam transport and the post accelerator chain by modelling.
- Reduce tuning and set-up time by providing tools → High level applications task force.
 - Model coupled beam tuning (provide set values)
 - Envelope Code allows visualization of tune changes with quadrupole strength, cavity amplitudes etc.
- Beam dynamics investigation in international collaboration - High-luminosity LHC

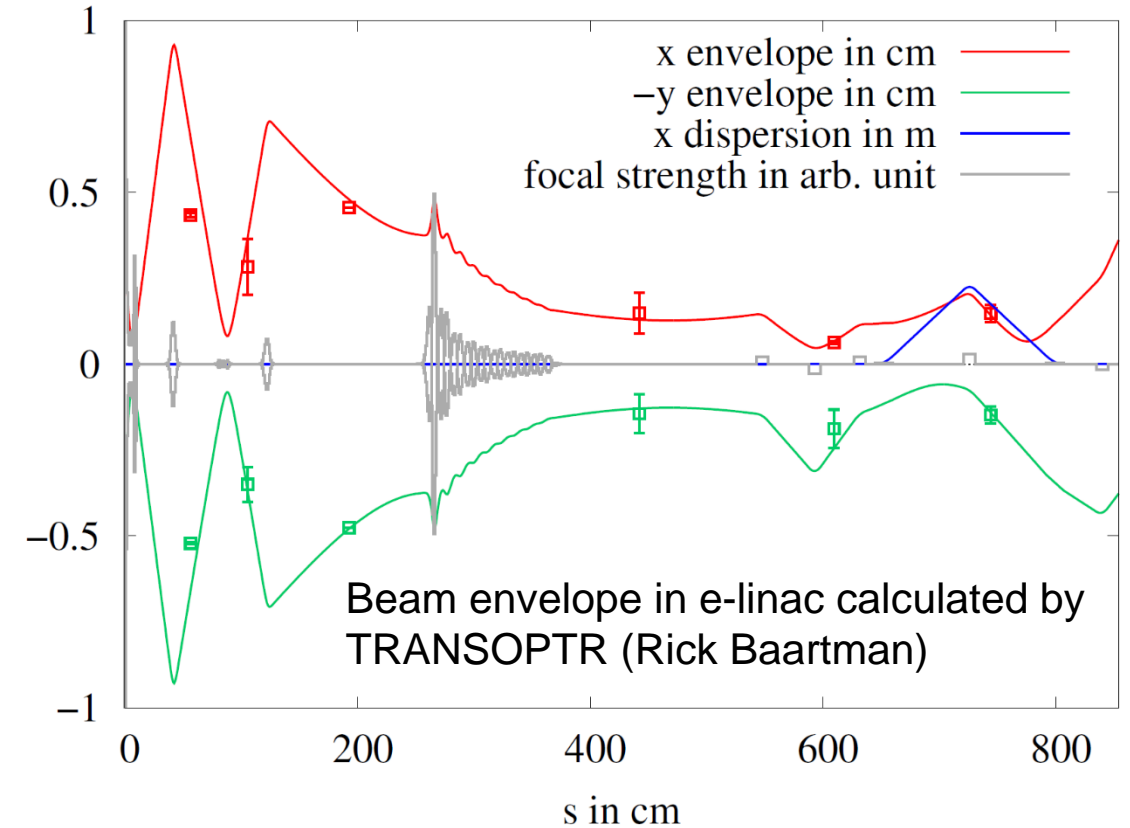

Thesis of P. Jung, P. Belanger, O. Shelbaya and S. Kiy

see talk of T. Planche

High power RIB production

- First ever high-power electron-gamma converter RIB production!
 - Converter target material tests with Ta and Au performed → feasibility demonstrated with Ta.
- Proton-to-neutron converter for intense and pure RIB beams
- Target Material Research
 - Nanofiber actinide materials
 - Novel target material synthesis and conditioning
- Target ion sources
 - Towards non resonant ionization and compact Ti-sapphire laser for "non-expert" operation
 - Multi-physics approach to understand the mechanism of production and extraction of ions in and FEBIAD Ion sources

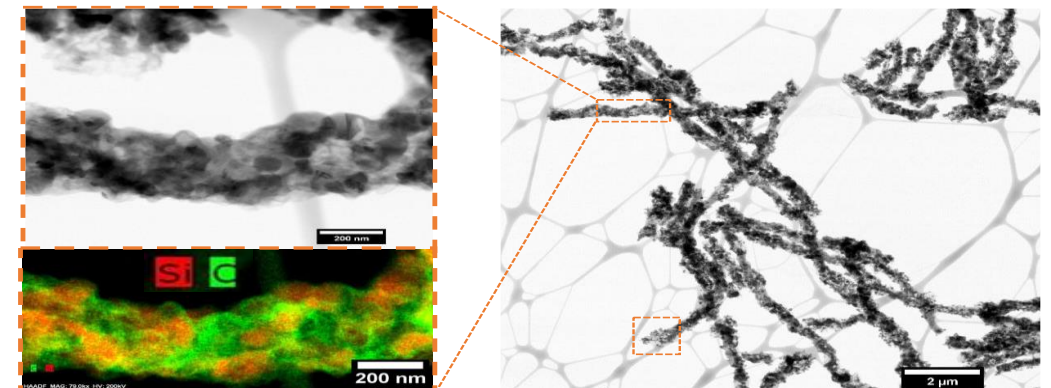
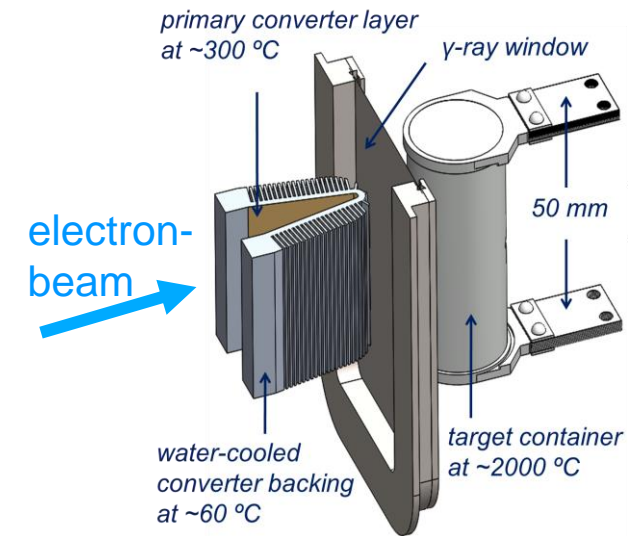

Thesis of L. Egoriti, M. Cervantes, F. Boix Pamies

See talk of Alexander Gottberg

TRIUMF is internationally recognized for its leading role in remote handling, hot cell design and operation.

RH robotics development



TRIUMF RH specialists assisting in T2K target repair



Automation, modern controls

- Design study for robotic inspection and repair tools for the beam line 1A refurbishment
- TRIUMF remote handling and target technologies as well as the know-how of HQP are valued by international collaborations! (T2K, MYRRHA, LBNF, HYPERK)

Examples of international designs based on TRIUMF RH:

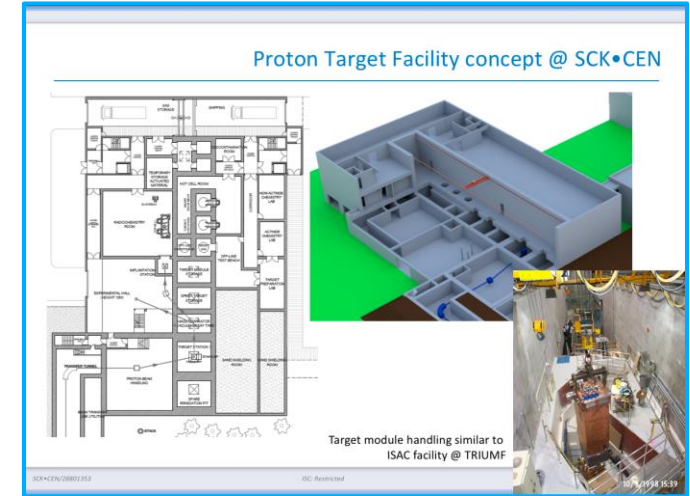

TRIUMF Superconducting-RF Infrastructure

- TRIUMF hosts two SRF linacs (ISAC-II and electron-linac) and SRF supporting infrastructure.
- UHV RF induction oven used to explore various heating/doping recipes → designed to accommodate different cavity types
- Activities range from student R&D on test resonators, to work for others (prototyping cavities and components) to full cryomodule assemblies



P. Kolb (PDR)
Thesis of R. Gregory

Superconducting Radio Frequency- SRF

- The cavity program is coupled with fundamental studies using two world class material science probes - μ SR and β -NMR
 - TRIUMF SRF group have used both to shed light on the breakdown fields for SRF application (3 journal papers published by Tobias Junginger et al.)
 - New surface treatments aimed at engineering a `dirty' Nb (doped) surface layer to shield bulk from high surface currents to extend peak field (ILC)
- New beamline in β -NMR allows testing doped Nb and new materials to push towards higher gradients (ILC)

See talk from Zhongyuan Yao

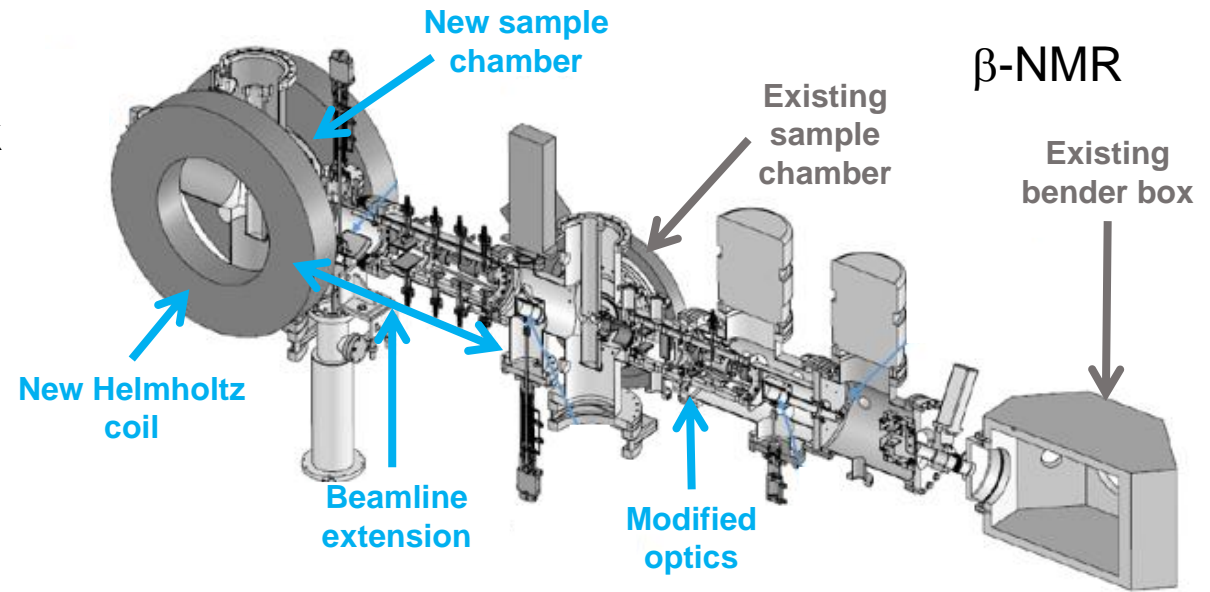
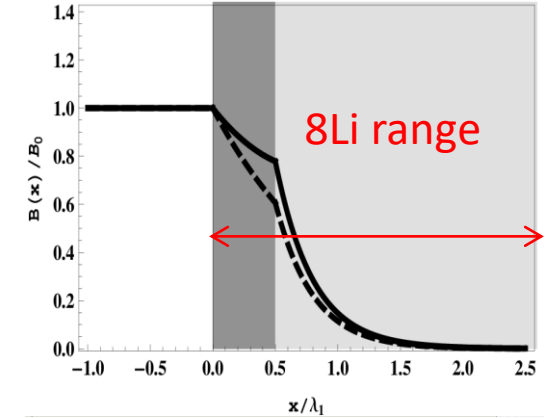
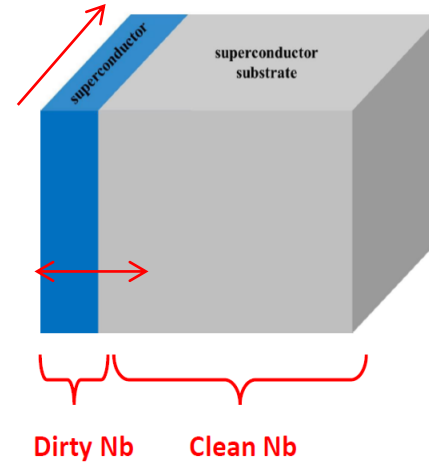

Thesis of E. Thoeng, A. Asaduzzaman

The Accelerator Science research program – summary

- **Beam physics and instrumentation**
 - Intense beams, modeling - space charge effects, beam-beam effects
 - Particle sources, automatic beam tuning, beam instrumentation
- **Secondary particle production**
 - Target materials and converter technology
 - Optimization of beam extraction and Laser ionization schemes
 - Target station technology – first ever online high-power target transfer system
 - High power target remote handling
 - Beam line maintenance in high radiation fields → remote handling engineering
- **Superconducting RF and RF**
 - SRF cavity development – RF-separator, cavity processing
→ towards higher gradients
 - Reduction in production complexity and reduced cost material choices
 - New processes and material investigation with mSR and bNMR.

Young researchers involved:
undergraduate and graduate
students as well as post
doctoral fellows.
Key role has UVic!

Accelerator Science - National context

ACC division connects to Canadian Universities via the student program (Coop students, thesis projects, lectures and seminars) and via joint accelerator science projects:

- Compact Accelerator Driven Neutron Sources - common driver beam are protons (Talk of Drew Marquardt, Windsor University)
- Using the e-linac as sources for intense high field THz radiation (Talk of Scott Hopkins, University of Waterloo)
- Collaboration with CLS and USask on SRF, magnets and education (Mark Boland)
- Student education and science program with partner UVic

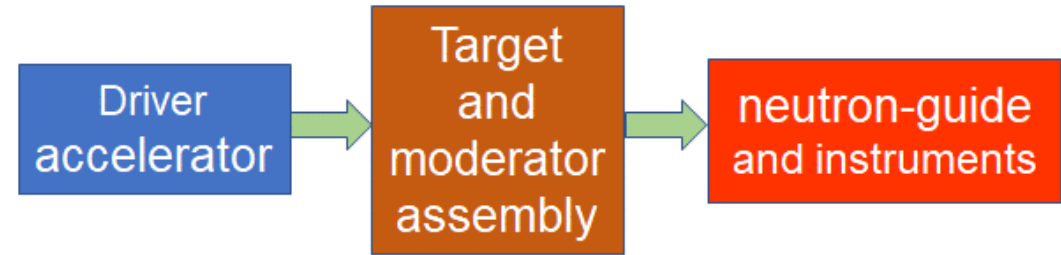

Compact Accelerator Driven Neutron Sources – CANS

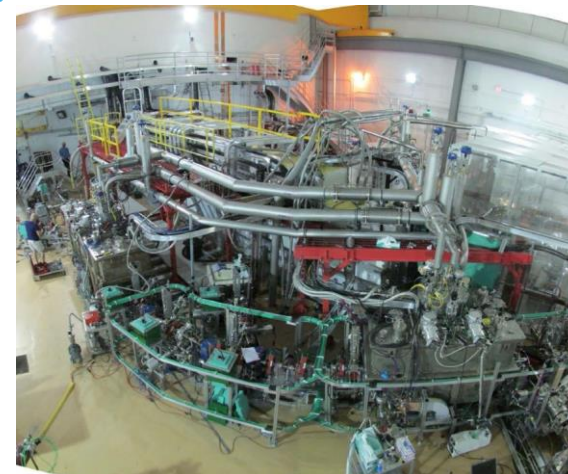
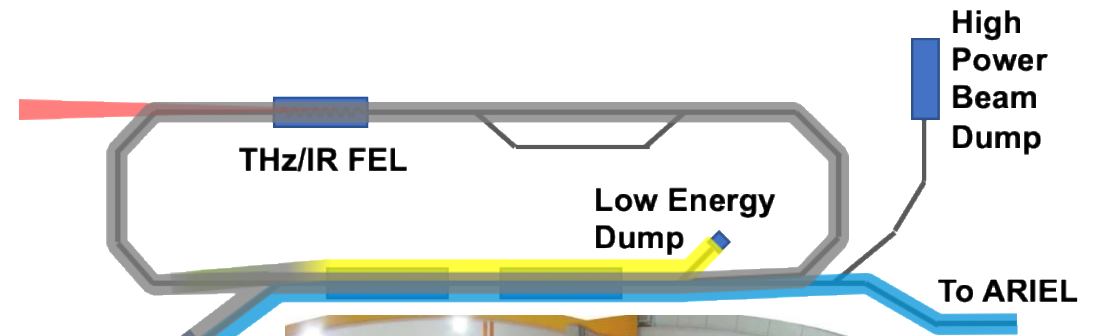

Accelerator related projects at TRIUMF connect to the most advanced accelerator-based research labs in the world for example:

- CERN, DOE labs (FNAL, Jlab, BNL etc.), KEK and J-PARC in Japan,
- Helmholtz labs in Germany (GSI, HZDR, FZJ and DESY), SCK-CEN in Belgium,
- VECC in India, IBS-RISP in South Korea

→ Common projects, exchange of expertise, work forces and equipment

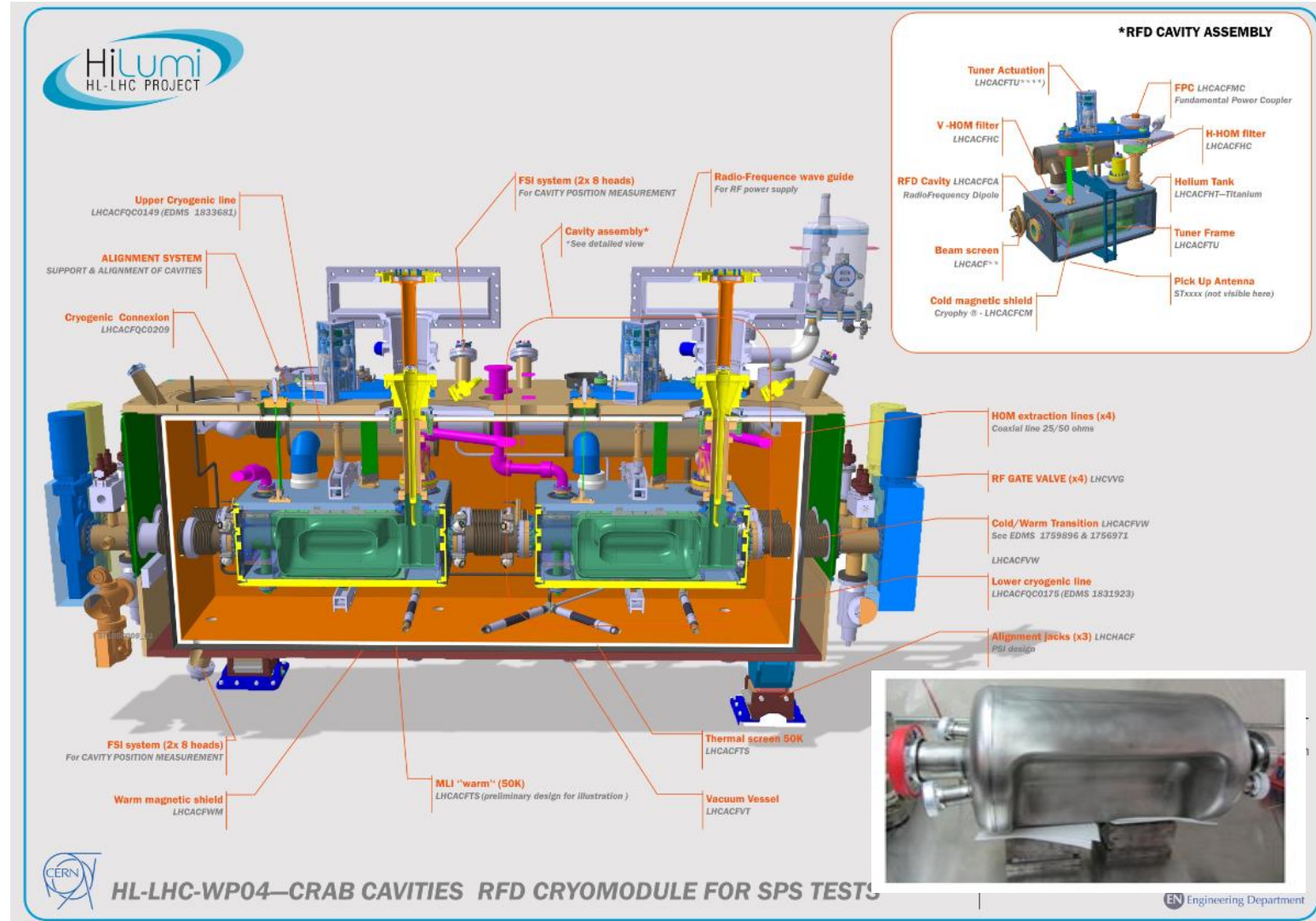

See talk of Robert Laxdal

Summary

- **TRIUMF underlies Canada's strength in Accelerator Science by**
 - designing, constructing and operating high-performing, unique accelerator systems featuring a wide variety of particle beams.
 - providing Canada with a world-class platform in beam physics and instrumentation, in secondary particle production and in Superconducting RF.
 - enabling specialized disciplinary and cross-disciplinary training that attracts leading scientists to Canadian universities.
- **Accelerator Science at TRIUMF**
 - supports the high performance and availability of TRIUMF's accelerator complex with new developments or by adding new capabilities in collaboration with Canadian Universities and international partners.
 - connects Canadian Universities with top level experts at TRIUMF and global partner labs.
- **TRIUMF accelerators**
 - serve a broad scientific and applications program producing muons, neutrons and rare isotopes.
 - provide world's highest driver beam power for the production of rare isotopes.
 - enable science that is world-class in accelerator physics and technology

Thank you
Merci

www.triumf.ca

Follow us @TRIUMFLab



Backup

More information on TRIUMF's R&D capabilities, particularly their uniqueness and depth of technical expertise in accelerator development:

- Accelerator systems: RF (low level and power RF, SRF, cavity development), cryomodules, vacuum (including UHV), cryogenic systems, power converter technologies, high and low intensity beam diagnostics (ions and electrons), machine protection
- Beam physics: Beam physics modeling and support for design, commissioning and operation (HLA), simulation codes, physics of space charge dominated proton and electron beams
- ISOL systems: High power RIB targets, target ion sources (SIS, FEBIAD, LIS), in-target beam purification technologies (IG-LIS, cold transfer line, proton-to-neutron converter)
- Ion sources development and operation
Stable Ion Sources: H^- , SIS, rf-sources, Charge state breeder (ECRIS, EBIS), Target ion sources (RILIS, FEBIAD)
- Beam transport systems: Electrostatic and magnetic beam line systems, high resolution mass separators
- Operation of a sophisticated accelerator facilities with simultaneous delivery of multiple beams.
Accelerators know how: Linacs (heavy ions and electrons) normal and superconducting, cyclotrons (H^-), synchrotrons, FFAGs
- Remote handling: Hot cell technology, irradiated target handling (ISAC, cyclotron beam line), handling of activated and contaminated parts, cyclotron services, muon production targets

Example: FEBIAD Ion Source R&D

Space charge in a magnetic field

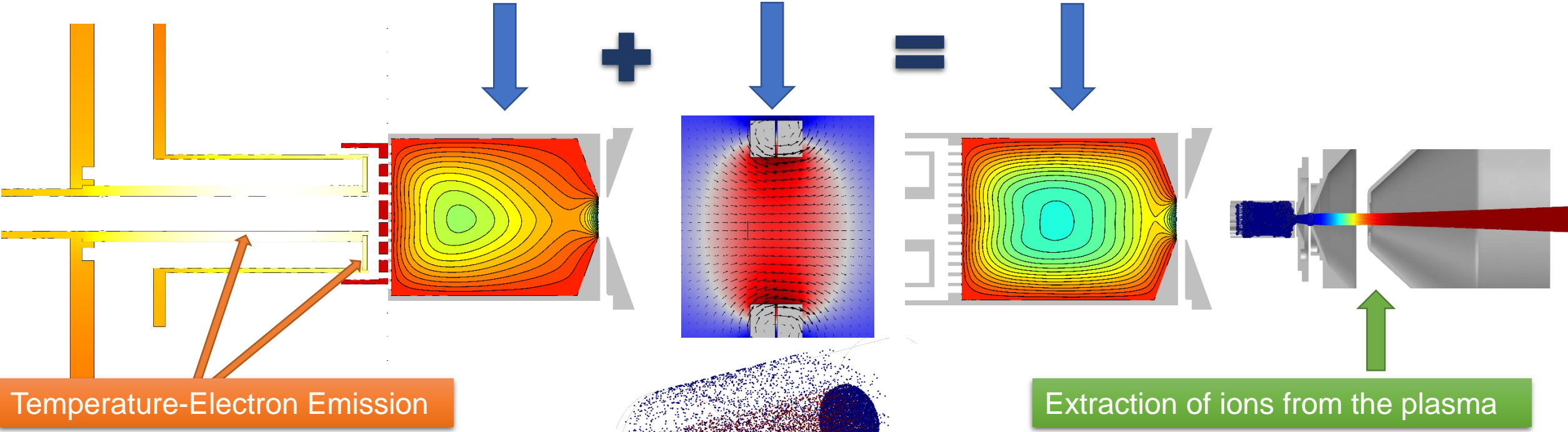

Temperature-Electron Emission

Electron Impact Ionization modelled

Extraction of ions from the plasma

Experimental measurements to benchmark simulations and drive geometry and parameter optimizations

Thesis of F. Maldonado