

Status of FPC and HOM absorber for EIC crab cavities

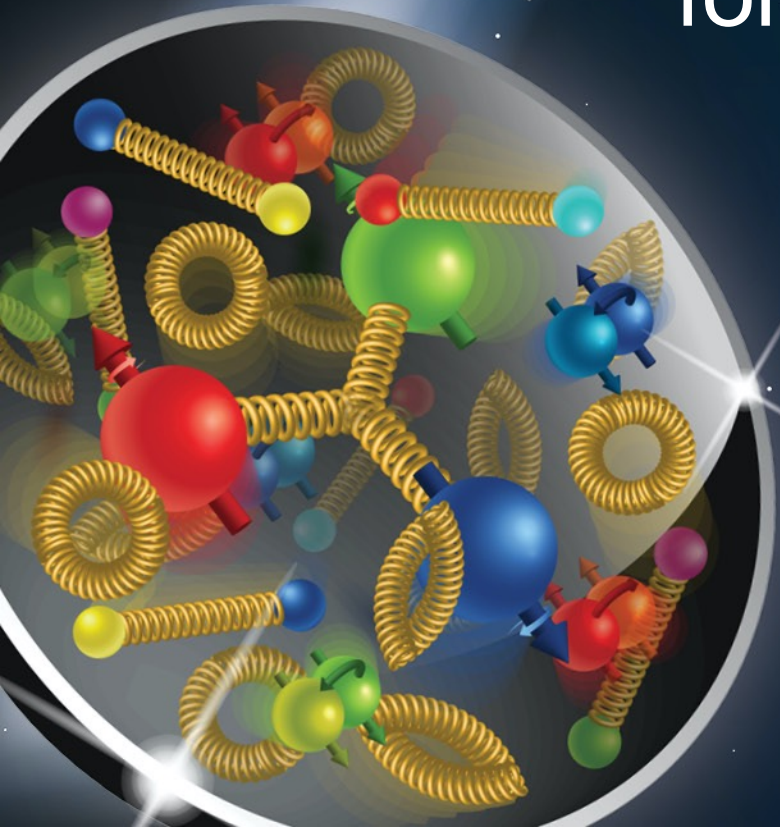

Wencan Xu

Oct. 27, 2021

Electron-Ion Collider

Outline

- Fundamental power coupler for crab cavity
 - Power and other requirements for FPC for crab cavity
 - Options and status of FPC development
- HOM absorber for crab cavity
 - HOM damping requirement for crab cavity
 - Prototyping and status of HOM absorber
- Summary

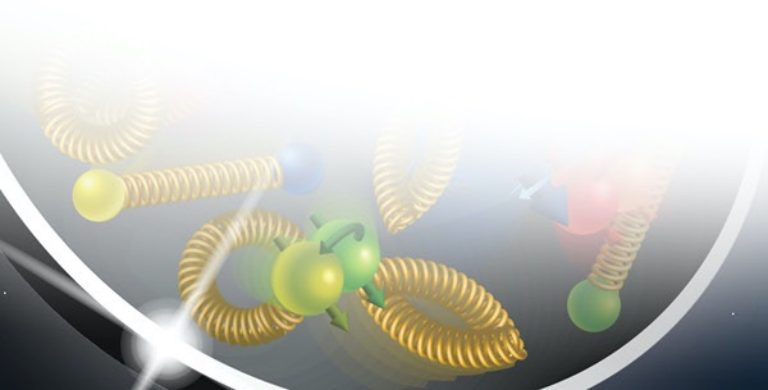

Power Requirement for HSR 197 MHz Crab Cavity

- Power requirement:

$$P_g = \frac{1}{8} \frac{|\vec{V}_\perp|^2}{(R/Q)_\perp Q_{load}} \left\{ \left[1 + \frac{2(R/Q)_\perp \kappa \gamma Q_{load} * I_{b0} \cos \phi_b}{|\vec{V}_\perp|} \right]^2 + \left[2Q_{load} \frac{\Delta \omega}{\omega_0} + \frac{2(R/Q)_\perp \kappa \gamma Q_{load} * I_{b0} \sin \phi_b}{|\vec{V}_\perp|} \right]^2 \right\}$$

- For 197 MHz hadron crab cavity
 - Beam current: 1 A
 - Voltage: 11.5 MV
 - bunch phase: 0 rad
 - Microphonic: 50 Hz
 - Beam offset: 0.6 mm (max.)
- Optimum loaded Q: 1.75 e6, which corresponding to RF power= 47 kW

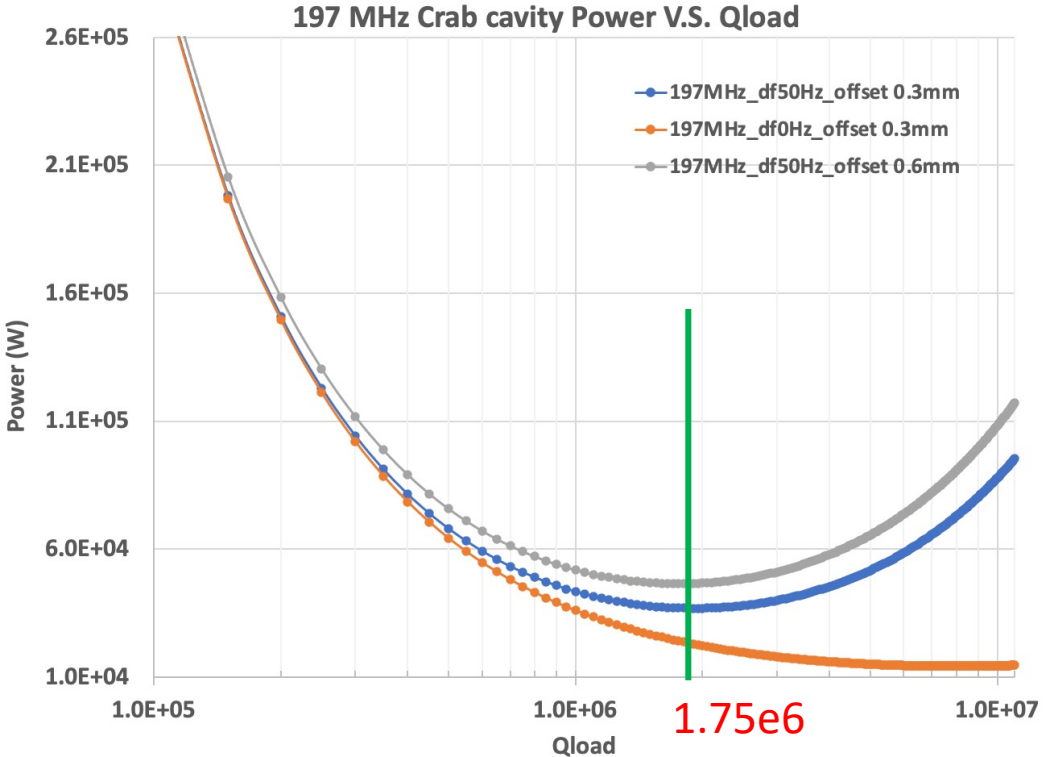

- FPC power requirement: 60 kW, CW full reflection.

Power Requirement for eSR 394 MHz Crab Cavity

- 394 MHz HSR crab cavity has lower current (1 A vs 2.6 A), so the power requirement is much smaller than the 394 MHz ESR crab cavity.
- However, the power coupler will be the same.

- For: 394 MHz ESR crab cavity
 - Beam current: 2.6 A
 - Voltage: 3.5 MV
 - bunch phase: 0 rad
 - Microphonic: 50 Hz
 - Beam offset: 0.25 mm (max.)

- Optimum loaded Q: 1.8 e6, which corresponding to RF power= 20 kW



- FPC power requirement: 30 kW, CW full reflection.

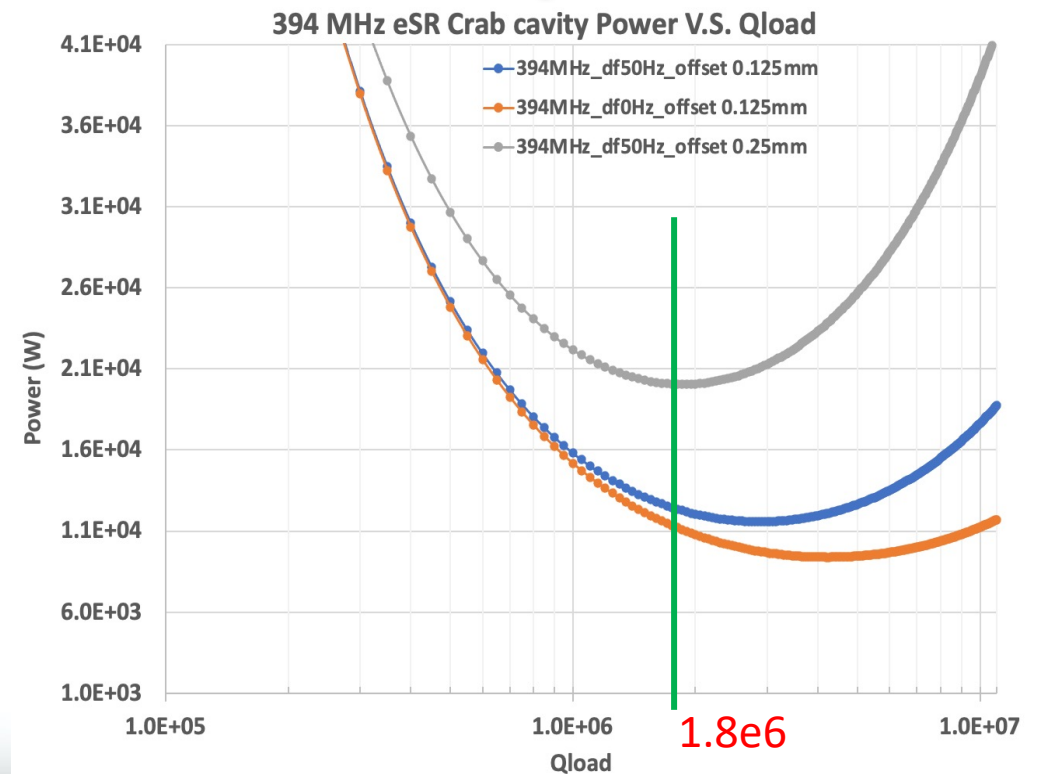

FPC requirement for crab cavity

- Mechanical requirements
 - The cryomodule needs to be shipped from JLAB to BNL
 - FPC window assembly (vacuum parts) has to survive 5 g impact load in any direction for road trip
 - Microphonics are a big contribution for the RF power (previous slide), so modal resonant frequency has to be larger than 100 Hz
- Space limitation
 - There are two potential FPC orientations for crab cavity.
 - Installation and maintenance
 - repair (window swapping)

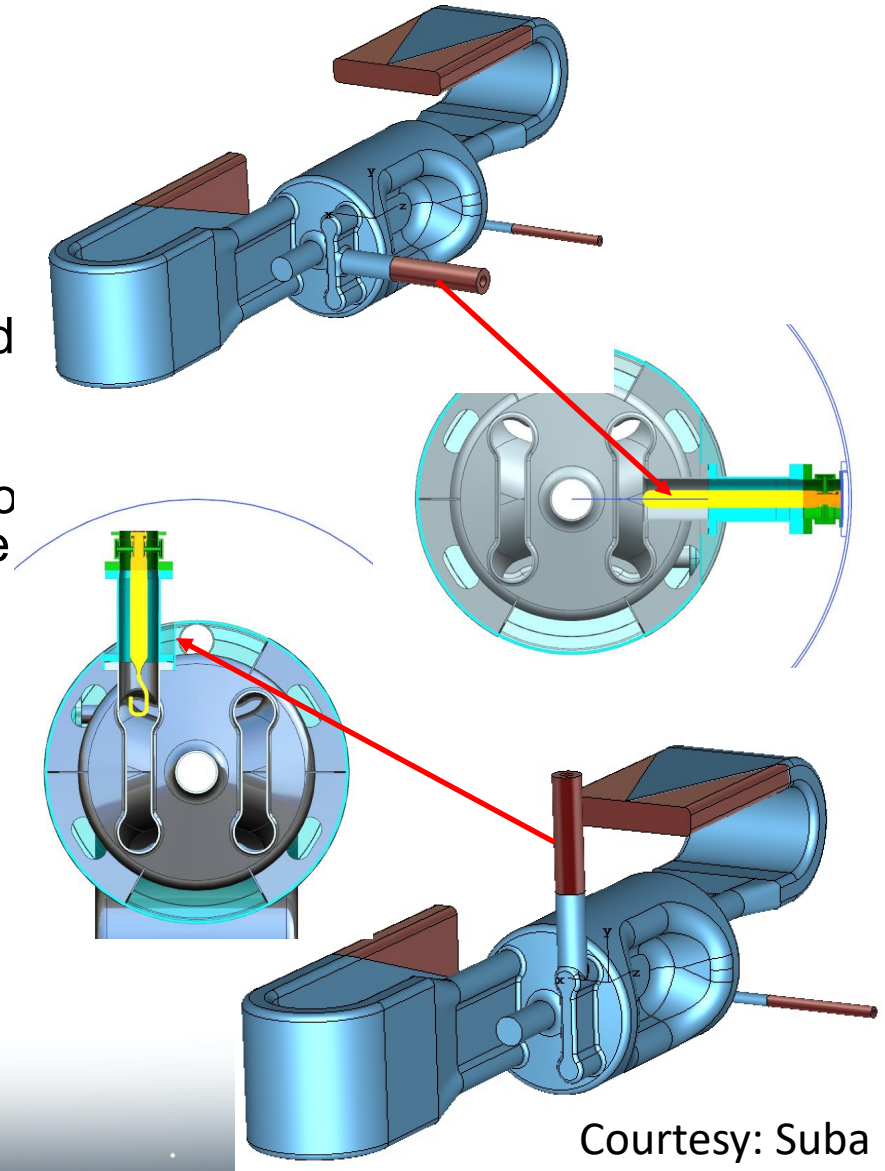

Potential FPCs for Crab Cavity

- FPC-crab cavity integration study is ongoing, two potential FPCs are under consideration: SNS coupler and EIC ESR FPC
- SNS coupler on crab cavity
 - Power-wise, SNS coupler is able to operate up to 70 kW at 805 MHz, so it should be suitable for crab cavity.
 - However, preliminary layout showed that the center conductor would be 110 mm longer than SNS coupler as is. Detailed analysis of RF loss and mechanical properties need to be carried out for final determination.

SNS FPC

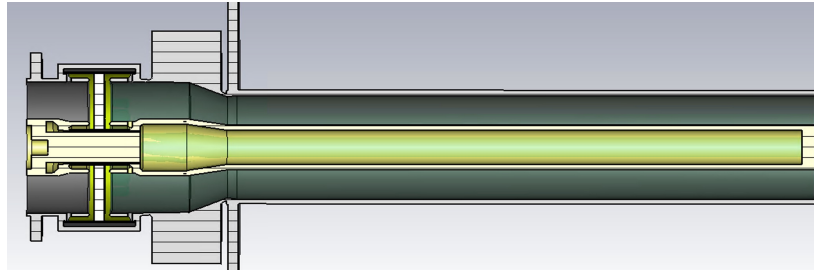

BNL EIC FPC

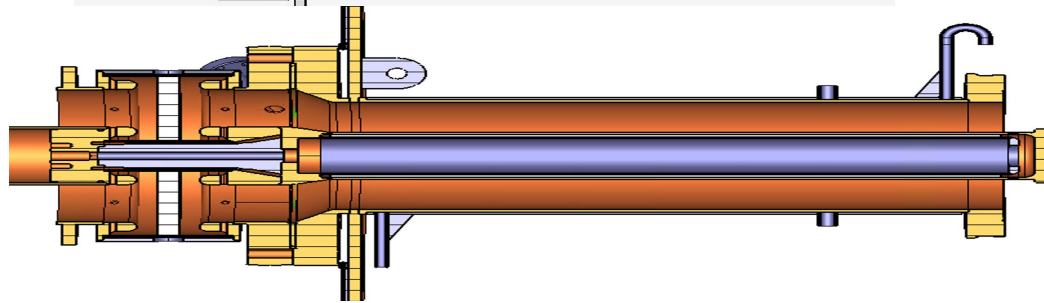

- EIC ESR FPC on crab cavity.
 - This coupler was designed for 500 kW CW, standing wave at 591 MHz.
 - Dimension-wise, it seems fit crab cavity application, so far.

Status of EIC 500 kW FPC

- EIC ESR FPC
 - Broadband window structure design to cover all EIC RF system frequency < 591 MHz.
 - 99.5% alumina window. Thick ceramic (10.5 mm) for mechanical robustness
 - Water cooling for inner conductor and helium cooling for outer conductor
 - Simulation showed delta T on window is only 10 C for 1 MW transmission power
 - Survive 5g load for road trip

- FPC design review was well accepted by an international technical review committee in June 2021.
- Detail engineering design toward manufacture to be finished by next April 2022
- We plan to fabricate pre-production windows in house.

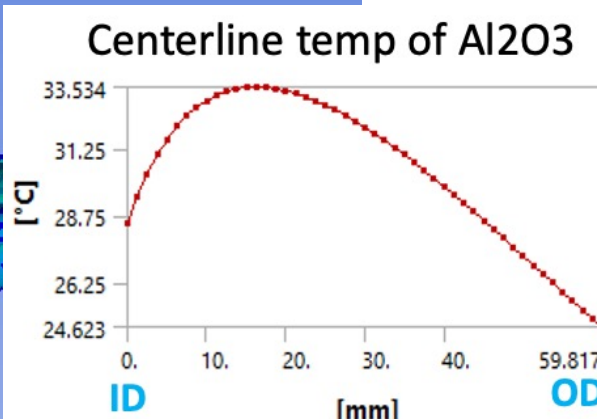
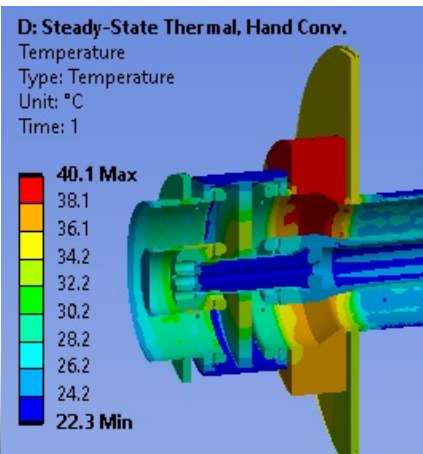
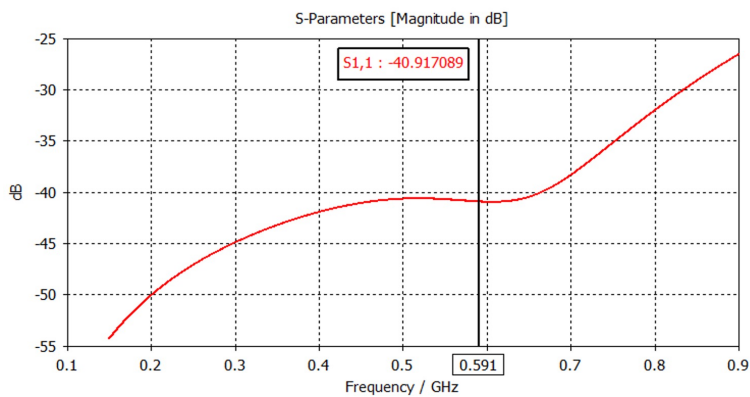
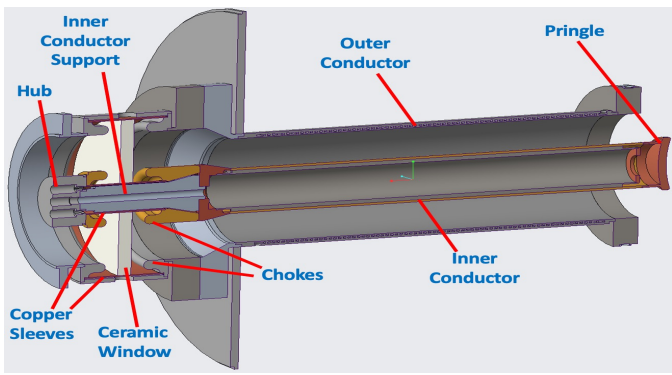

HOM Damping for Crab Cavities

- HOM dampers for both 197 MHz and 394 MHz cavities are not finalized. However, waveguide coupling to cavity was determined to satisfy tight impedance budget.
 - 197 MHz cavity: $Z_z = 10^4 \Omega$ and $Z_t = 0.25 \times 10^6 \Omega/\text{m}$
 - 394 MHz cavity (4 for eSR in two IPs): $Z_z = 6.5 \times 10^3 \Omega\text{-GHz}$ and $Z_t = 0.24 \times 10^6 \Omega/\text{m}$
- There are two options for crab cavity HOM damper
 - damper on waveguide
 - damper on coaxial line (transition to rectangular waveguide coupling to cavity)
- Broadband (up to 10 GHz), high power HOM (up to 20 kW) HOM absorber is needed.

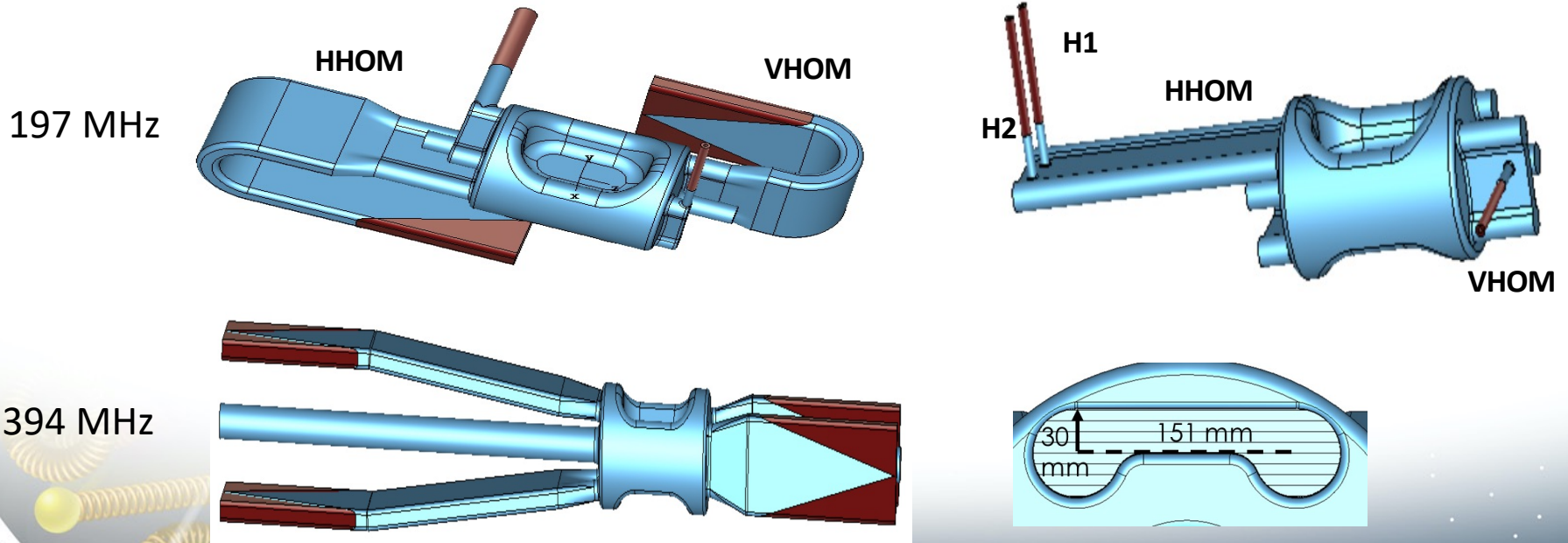

SiC HOM Absorber Prototyping

- R&D on SiC as ESR SRF cavity RT HOM absorber is ongoing at BNL: Test manufacturing of large SiC HOM damper, measure its bandwidth and power handling capability.
- Two techniques for prototyping HOM absorbers were studied.
 - Shrink-fit a solid cylindrical SiC HOM damper
 - Brazing SiC tiles on Cu base

• Solid cylindrical SiC HOM damper

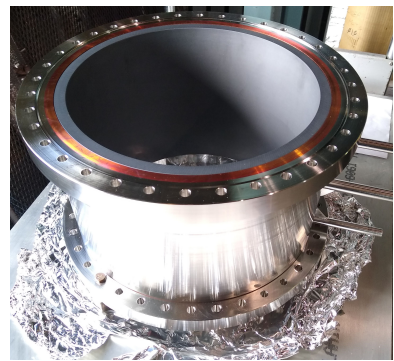

• Tile-style SiC HOM damper

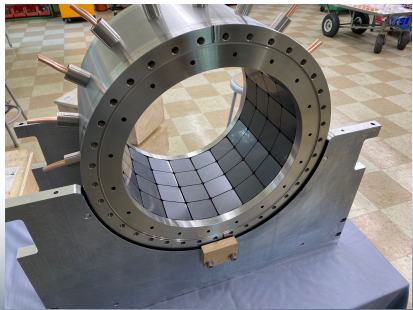
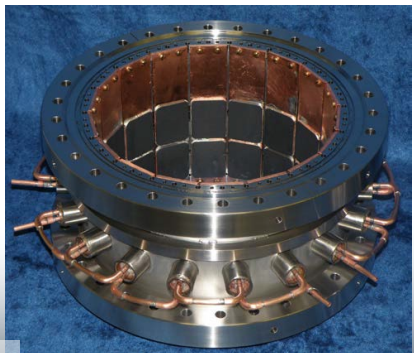

SBIR project with
TJS Technologies LLC

Courtesy: T. Schultheiss

HOM Damper Test Status and Plan

- First outgassing test was completed with solid SiC HOM damper.
 - Outgassing rate is $2.2e-10$ torr-liters/sec-cm²
 - Demonstrated interference-fit SiC assembly satisfies the high vacuum needs in EIC SRF cavities.
- Narrow band measurement on solid SiC HOM damper with waveguide transition at each side.
 - The result is close to expectation. → We will need 62 kW to test the 24 kW absorption at 704 MHz.
- Plan:
 - Broadband measurement on a transmission line with SiC HOM absorber as the outer conductor.
 - Outgassing and low power measurement on tile-style SiC HOM damper
 - High power test at 704 MHz to verify power handling.

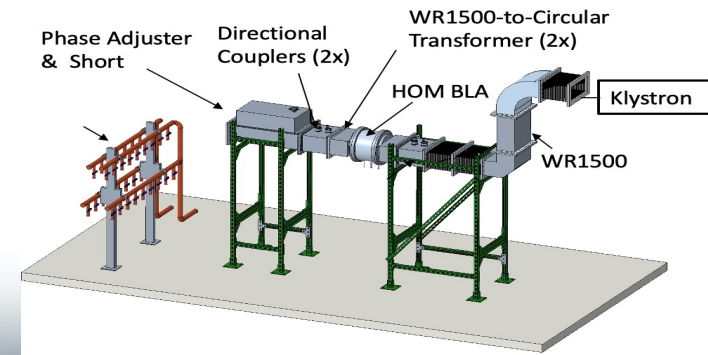
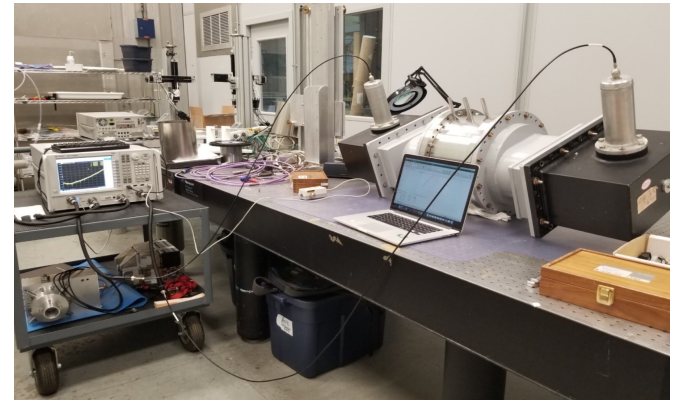
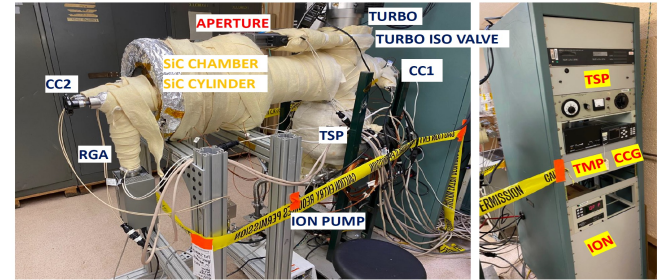

Summary

- FPC power and coupling requirement were studied for 394 MHz and 197 MHz crab cavity.
- Both SNS coupler and EIC 500 kW FPC are possible application for crab cavity. However, detailed mechanical analysis and system integration study has to be carried out for final determination.
- Crab cavities need broadband, high power HOM absorber to damp HOMs.
- Status of EIC ESR FPC and SIC HOM absorber R&D were reported.

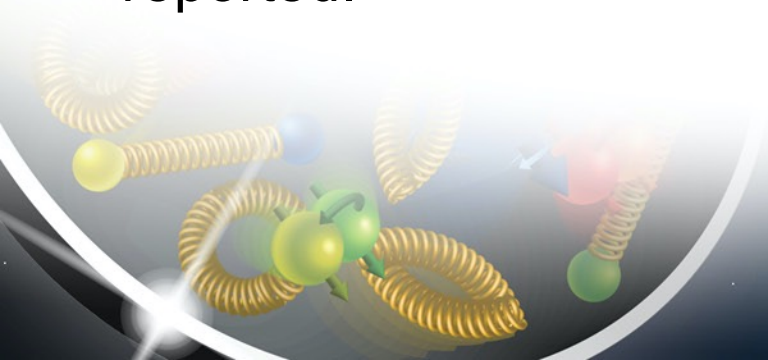

Thank you !

