

Relative Luminosity Measurements with ATLAS-TPX Network

Muhammad Usman

Prof. Claude Leroy (Thesis Supervisor)

Group of Particle Physics, University of Montreal

Overview

- ATLAS Luminosity Measurement overview.
- ATLAS-TPX (a network of pixelated Timepix detectors installed in ATLAS cavern) overview.
- ATLAS-TPX Luminosity Algorithms.
- Results from the developed Algorithms.
- Long Term Stability Studies.
- Conclusion

Luminosity Measurement in ATLAS

- Luminosity measurements are of crucial importance as they determine the precision of any physics cross section measurement.

$$N = L \times \sigma$$

event rate (pointing to N), Cross section (pointing to σ), Luminosity (pointing to L)

- For **Absolute Luminosity measurement at a collider**, we need a detector that can measure the event rate and can be calibrated in the Van der Meer (VdM) Scan. The LUCID detector is the main luminosity provider of the ATLAS experiment which can be calibrated in the VdM Scans to provide absolute Luminosity measurement.

$$\mathcal{L}_b = \frac{f_r n_1 n_2}{2\pi \Sigma_x \Sigma_y} = \frac{\mu_{\text{vis}} f_r}{\sigma_{\text{vis}}}$$

- For **Relative Luminosity measurement at a collider**, we need a detector that can measure the event rate and can be cross calibrated to a VdM calibrated detector. **ATLAS-TPX network**, Calorimeter subsystems (FCal, EMEC, Tile) and Inner Detector provide the relative luminosity measurements in ATLAS.

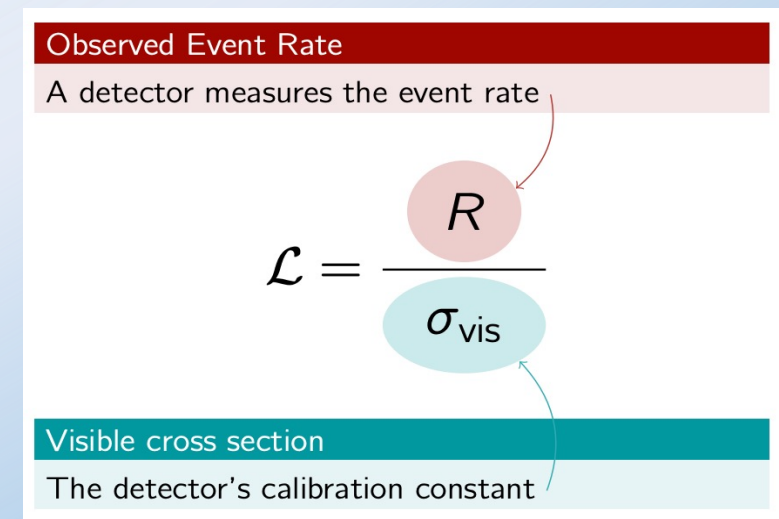

Luminosity Measurement in ATLAS

- Precision measurements of both the online and offline luminosity are a critical component of the LHC physics programme.
- Online luminosity with accuracy of $\sim 5\%$ was achieved in Run 2: required for operating the accelerator and the experiments to achieve physics goals (e.g. for performance optimization, trigger optimization).
- Precise offline luminosity measurement is important for all analyses, particularly for precision cross section measurements.
- Typical running conditions for physics:

13 TeV high- μ

Parameter	2015	2016	2017	2018
Maximum number of colliding bunch pairs (n_b)	2232	2208	2544/1909	2544
Bunch spacing (ns)	25	25	25/8b4e	25
Typical bunch population (10^{11} protons)	1.1	1.1	1.1/1.2	1.1
β^* (m)	0.8	0.4	0.3	0.3–0.25
Peak luminosity $\mathcal{L}_{\text{peak}}$ ($10^{33} \text{ cm}^{-2} \text{ s}^{-1}$)	5	13	16	19
Peak number of inelastic interactions/crossing ($\langle \mu \rangle_{\text{peak}}$)	~ 16	~ 41	$\sim 45/60$	~ 55
Luminosity-weighted mean inelastic interactions/crossing	13	25	38	36
Total delivered integrated luminosity (fb^{-1})	4.0	38.5	50.2	63.4

ATLAS-TPX Network Overview

- Network of 15 double-layer Timepix detectors was installed in the ATLAS cavern at different positions (for LHC Run-2) as the successor of the Medipix network (LHC Run-1).
 1. Measurement of Radiation field composition (including neutrons, responsible for induced radioactivity)
 2. Luminosity studies
- ALL Timepix detectors will be replaced with Timepix3 detectors in ATLAS for Run-3.

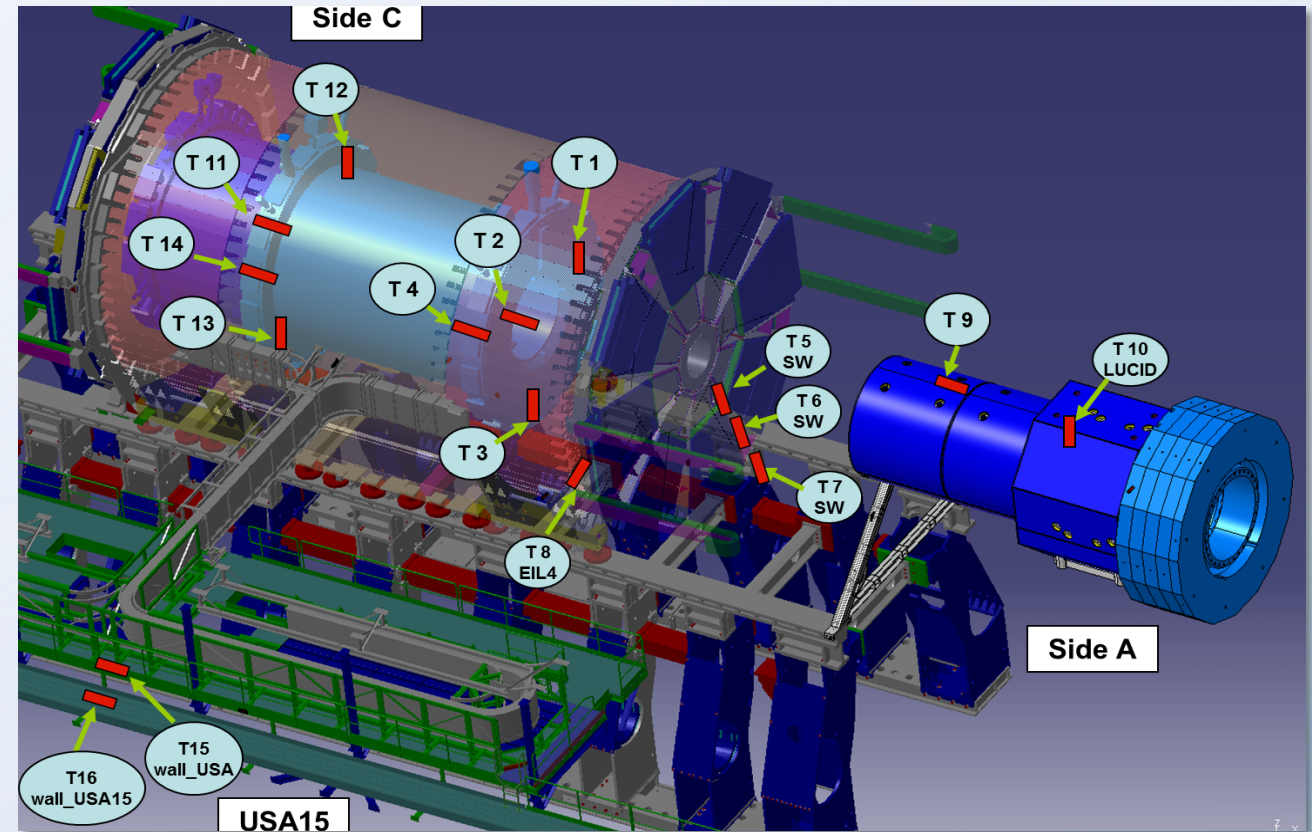

Overview of Timepix detectors positions in the ATLAS detector (partial illustration) and in the ATLAS experiment cavern.

[10.1088/1748-0221/11/10/P10002](https://doi.org/10.1088/1748-0221/11/10/P10002)

ATLAS-TPX Detector

- Silicon sensor area of $1.4 \times 1.4 \text{ cm}^2$ is segmented into 256×256 pixels with a pixel pitch of $55 \mu\text{m}$.
- Frame Based readout system.
- Bi-layer detector ($300 \mu\text{m}$ and $500 \mu\text{m}$).
- Equipped with neutron converters (^6LiF and polyethylene) for neutron detection.
- Three modes of operation : **ToA** (Time of arrival), **ToT** (Time over threshold), **Hit counting** modes.
- A particle interaction in the silicon sensor leaves a cluster, whose shape depends on the particle type, energy and incident angle.

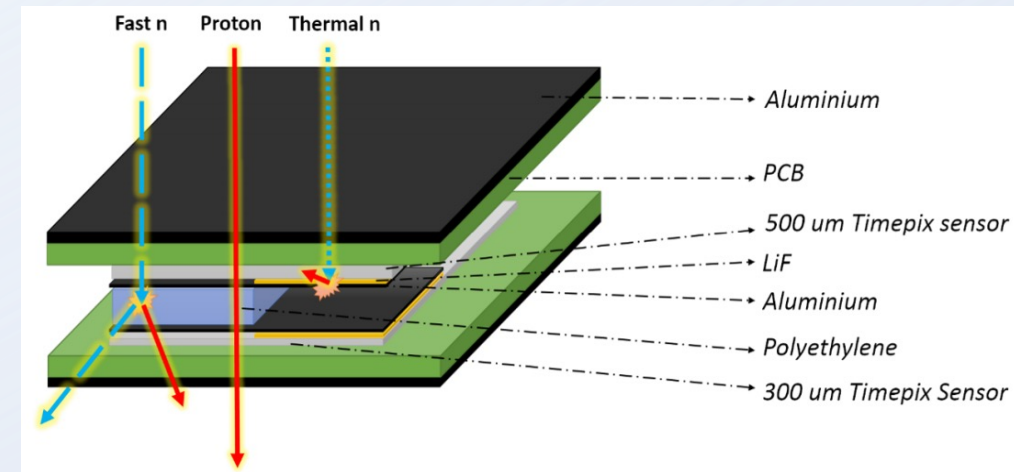
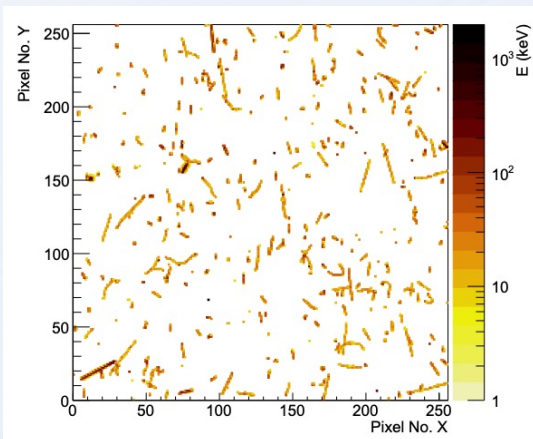
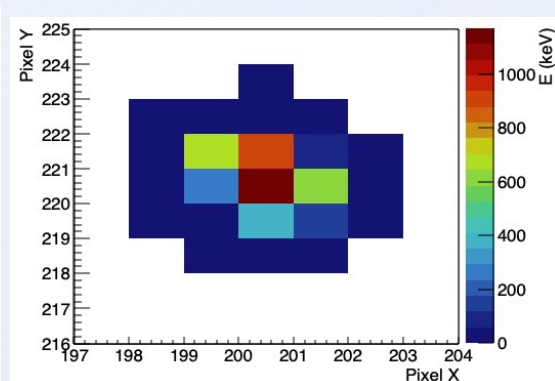

Diagram of ATLAS-TPX detector



Visualisation of raw data measured by an ATLAS-TPX detector



Heavy Blob from heavy ionising particles with short range (alpha particles, protons)

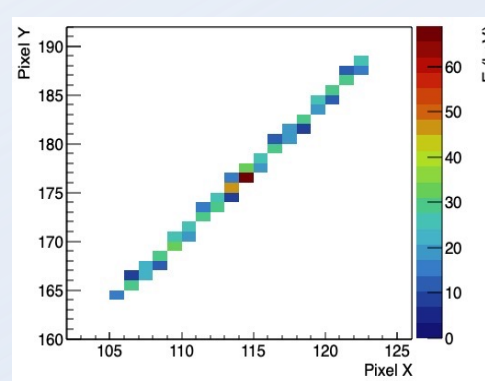

Straight track from Energetic light charged particles (mips, muons...)

<https://cds.cern.ch/record/2780463/files/ATL-SOFT-PROC-2021-019.pdf>

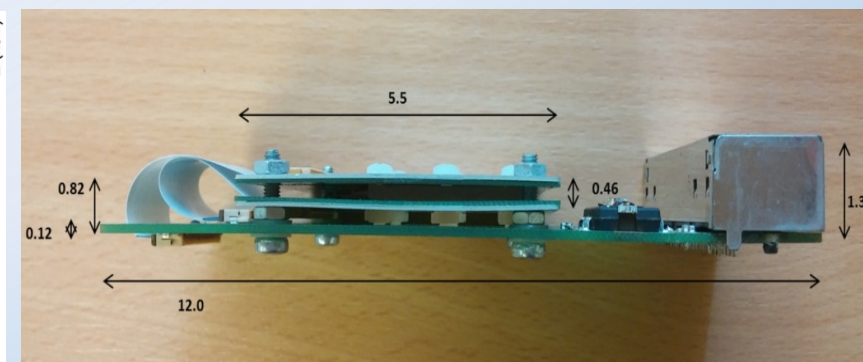

Timepix (TPX) hodoscope using two TPX sensors, operated at the Large Hadron Collider (LHC) Run-2. Distances are given in cm.

TPX Luminosity Analysis Strategy

- Separate Luminosity Measurement for both layers of each detector.

- Normalizing TPX Data to LiveTime (TPX detectors only)

- **Algorithms for Luminosity Measurements with TPX**

1. Hit Counting (with detectors operating in ToT, ToA and Hit counting mode)
2. Cluster Counting (with detectors operating in ToT and ToA counting mode)
3. Total Deposited Energy in Detector (with detectors operating in ToT mode)
4. MIPs (Minimum Ionizing Particles) Counting (with detectors operating in ToT and ToA mode).
5. Thermal Neutron Counting (with detectors that have thermal neutron converters)

- Cross Calibrate each detector and algorithm to the LUCID detector.

LiveTime Normalization =
 $(\text{TotalCounts}/\text{TotalFrames}) * (\text{LumiBlockSize}/\text{Frame Duration})$

Cluster Counting Algorithm

- Integrated total number of tracks (clusters) generated by ionizing radiation in the sensor layers.
- Graphs below show the Percentage Difference between LUCID and TPX Luminosity measurements for the Run 305618.

Run 305618 (Before Track Overlapping Correction)

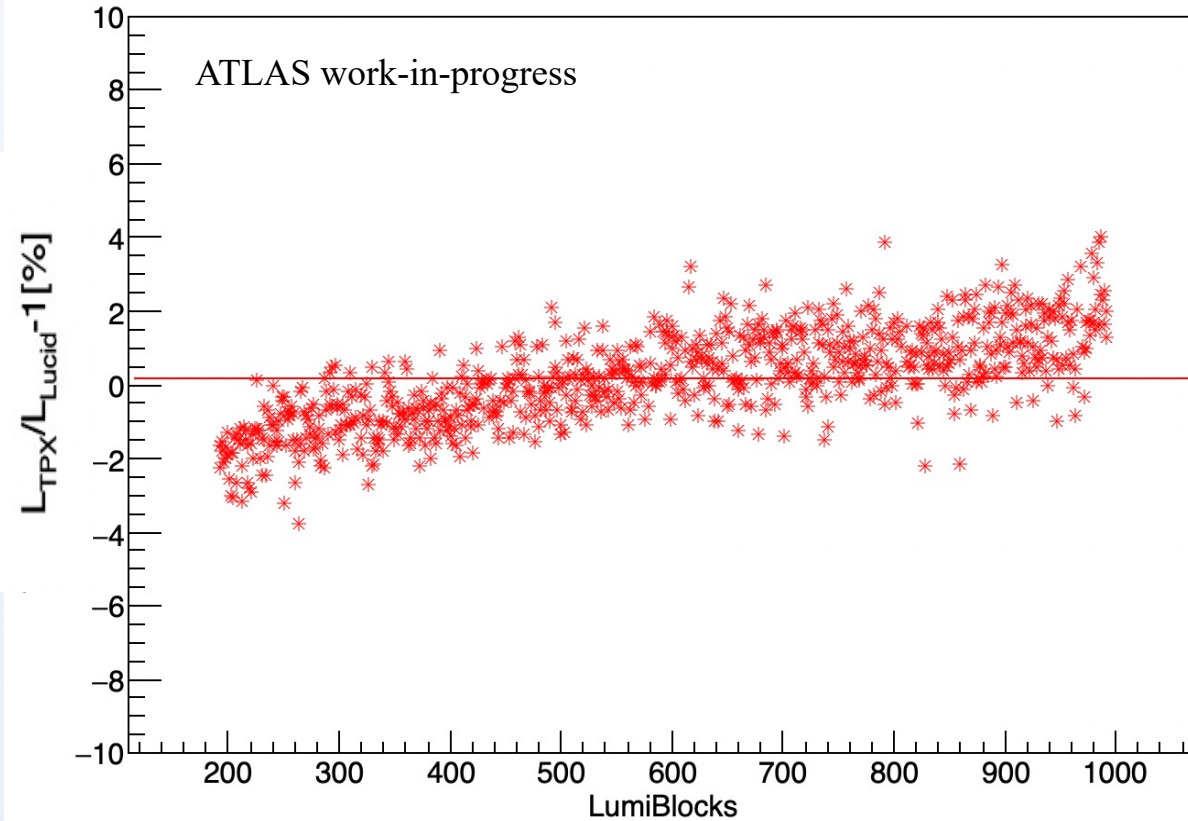

Run 305618 (After Track Overlapping Correction)

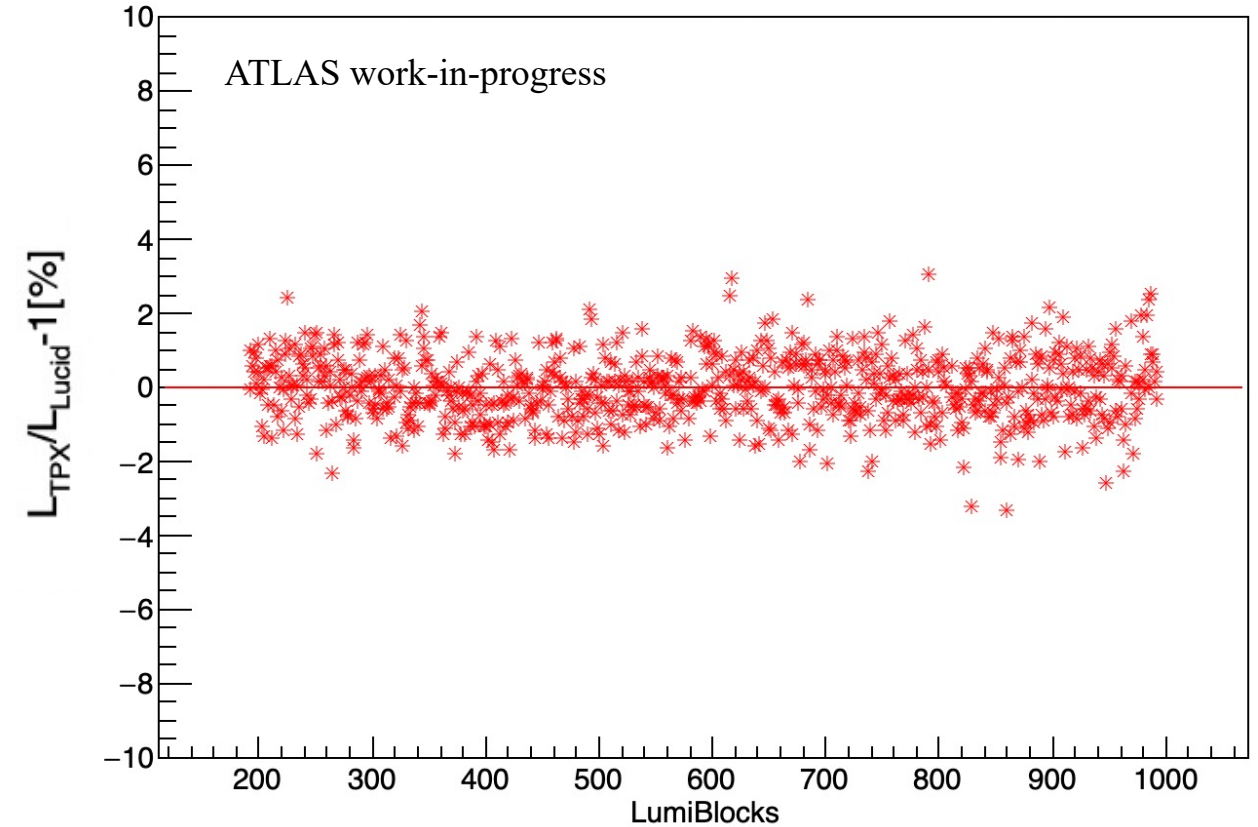

- At high Luminosity, the track (cluster) overlapping corrections need to be applied to cluster counting algorithm.

Hit Counting Algorithm

Integrated total number of pixel hits generated by ionizing radiation in the sensor layers.

- Graphs below show the Percentage Difference between LUCID and TPX Luminosity (Hit Counting and Energy Algorithm).

Energy Algorithm

Integrated total energy deposited by ionizing radiation in the sensor layers.

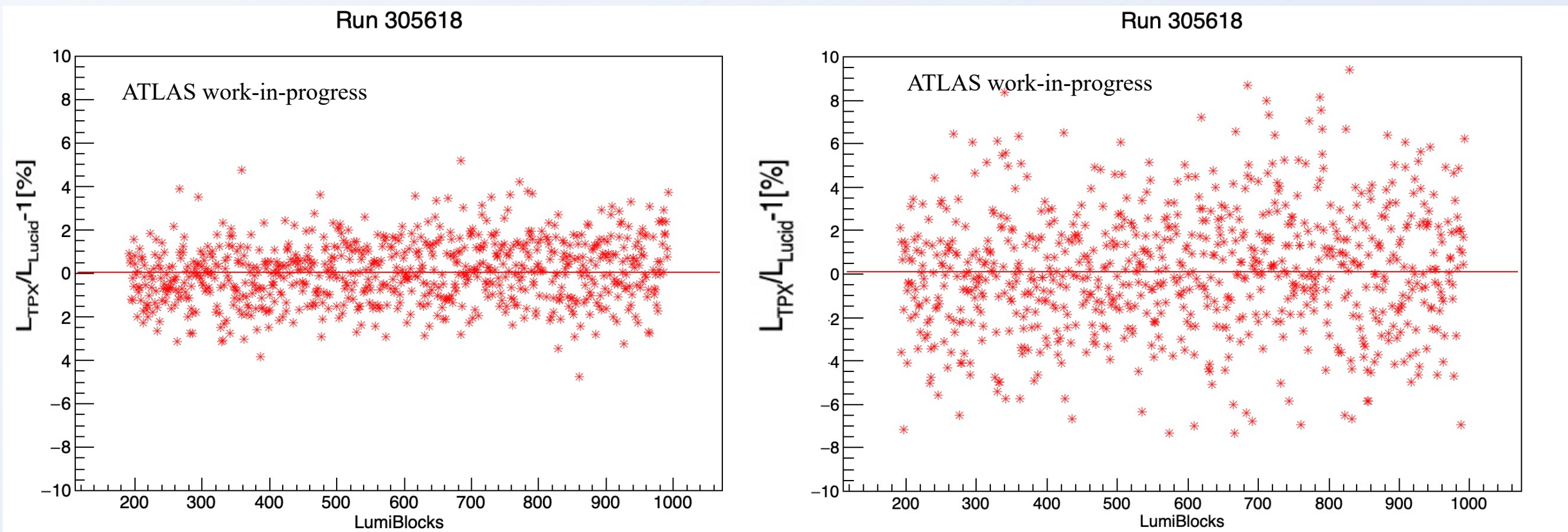

- Some Algorithms have more statistical Fluctuations than other algorithms.

Long Term Stability Studies

2016 Long Term Stability Studies

- Long Term Stability studies were performed with all TPX detectors.
- The TPX Luminosity measurement show agreement within 1% of the other Luminometers.
- TPX Detectors closer to interaction point show better results due to smaller statistical error.
- ATLAS-TPX detectors and algorithms in general seem stable in 2016 and throughout the run-2.

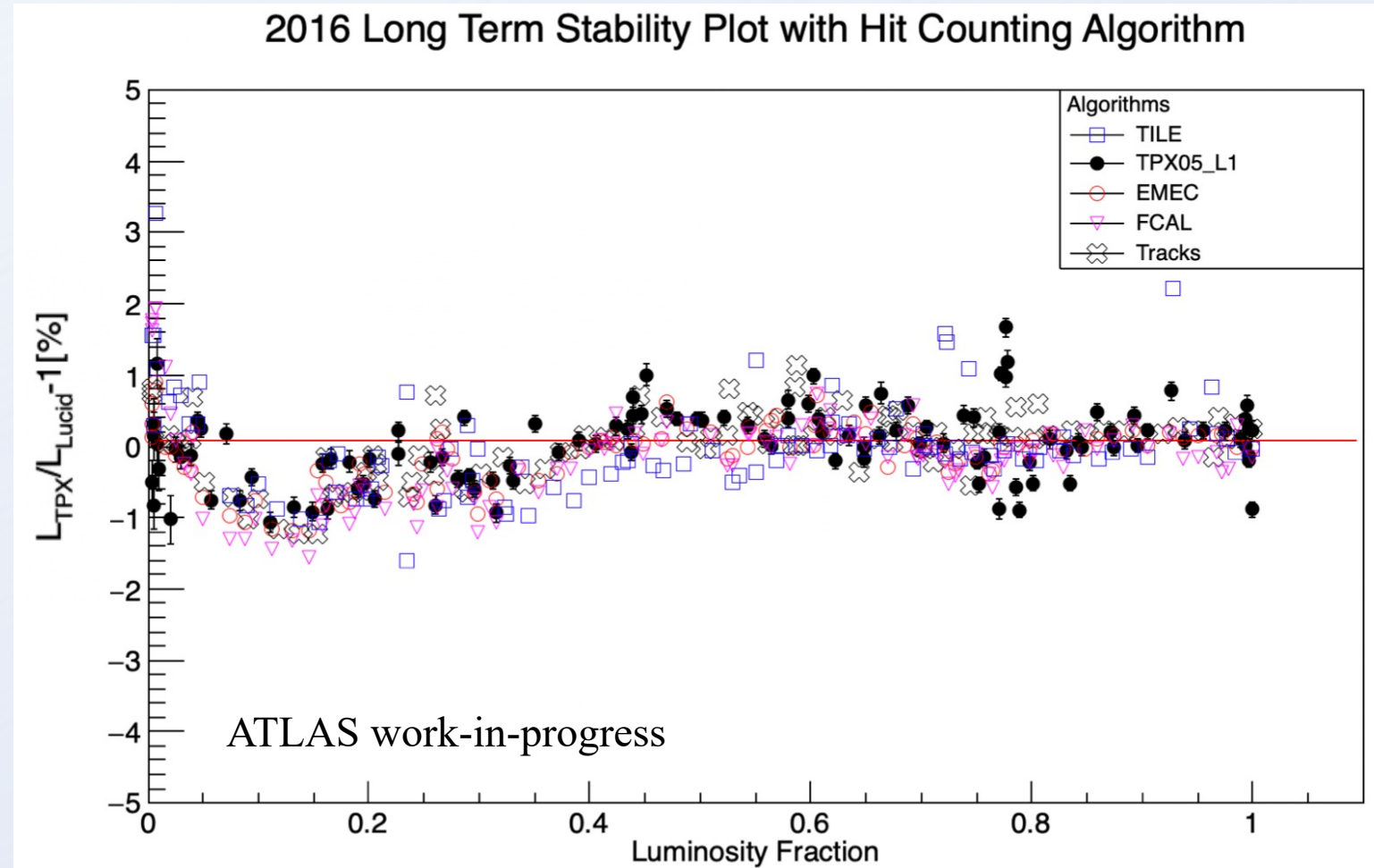

2018 Long Term Stability Studies

2018 Long Term Stability Plot with Cluster Counting Algorithm

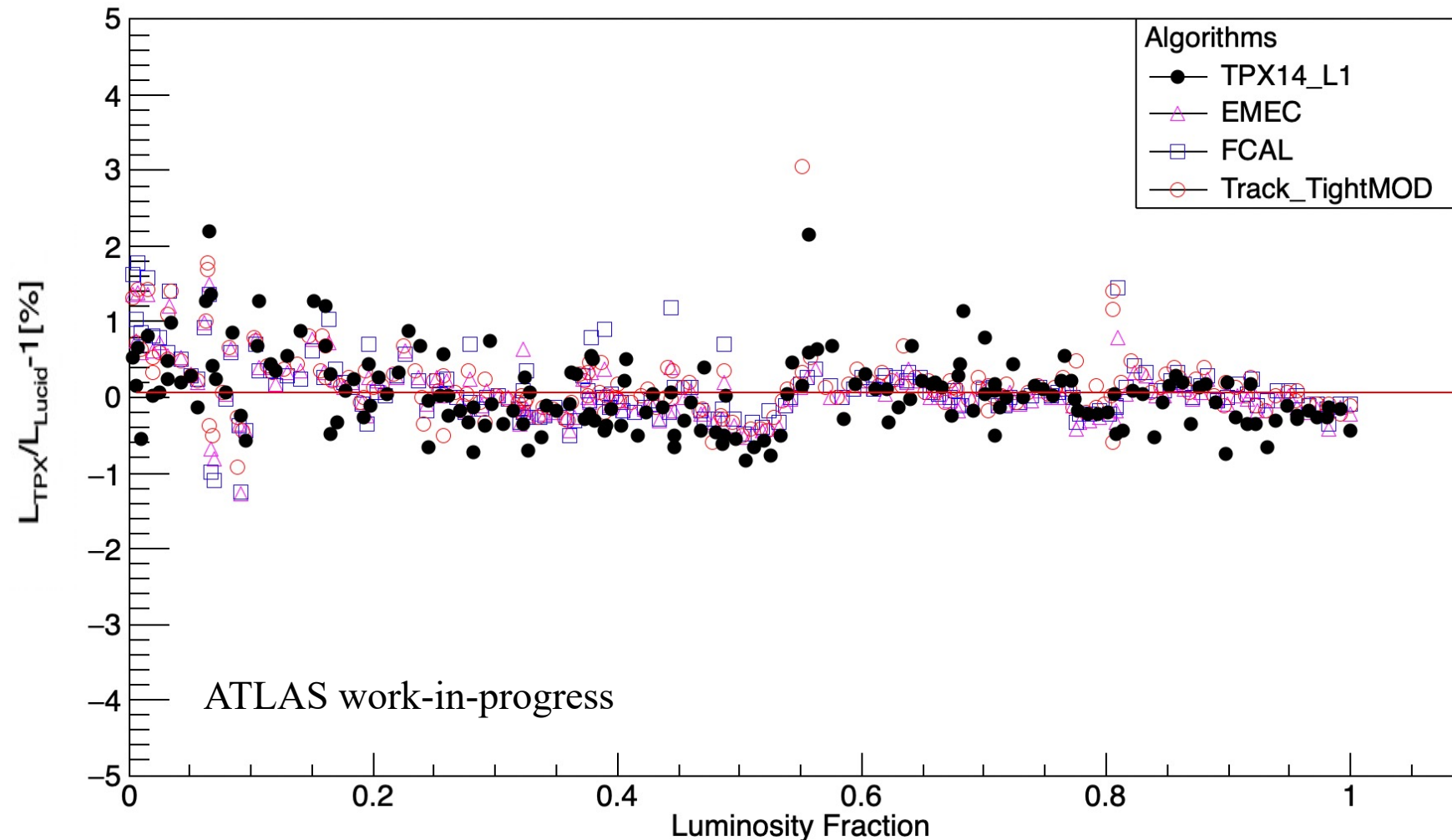

ATLAS-Timepix3 Network for Run-3

- For Run-3, the network is upgraded with the latest hybrid pixel detector developed by the Medipix3 collaboration i-e Timepix3.
- Noticeable improvements in detector technology for Run-3:
 - Time granularity: 1.56 ns.
 - Data-driven readout scheme.
 - ToF and ToA can be measured simultaneously.
 - Hit rates of $40 \text{ Mhits s}^{-1} \text{ cm}^{-2}$ can be achieved.
 - All devices are synchronized with the LHC orbit clock.
 - Much smaller deadtime to lifetime ratio 0.4%.
 - Energy Threshold : 3 keV
- Timepix3 were already tested in ATLAS during Run- 2.



Timepix-3 detector for Run-3

Next Steps



- Currently focusing on concluding the Run-2 studies before the Run-3 starts.
- There is always room for improvement : Development of new techniques to improve algorithms.
- Studies to remove the contribution from background and systematic errors in the signals : Activation and Cluster overlapping studies.
- Contribution to Pixel Cluster Counting Luminosity algorithm which is being developed for Pixel Luminosity Ring (Luminosity measurement detector for HL-LHC).

Acknowledgement

- The project is a collaboration between the Group of Particle Physics, University of Montreal and IAEP Czech Technical University in Prague.
- Special thanks to Professor Claude Leroy (Montreal) and Dr. Thomas Billoud (IEAP Prague) for their guidance throughout the project.

Thanks

Backup Slides

Cluster Overlapping Correction

- Timepix detectors have frame based readout system.
- At high luminosity, ATLAS-TPX detectors suffer from cluster (track) overlapping due to large number of clusters in one frame.
- Many overlapped clusters are counted as a single cluster by the clustering software. This results in lower measurement of count rate than actual count rate.
- We have worked on a simple manual technique to estimate the deviation in the count rate due to cluster overlapping at high luminosity.

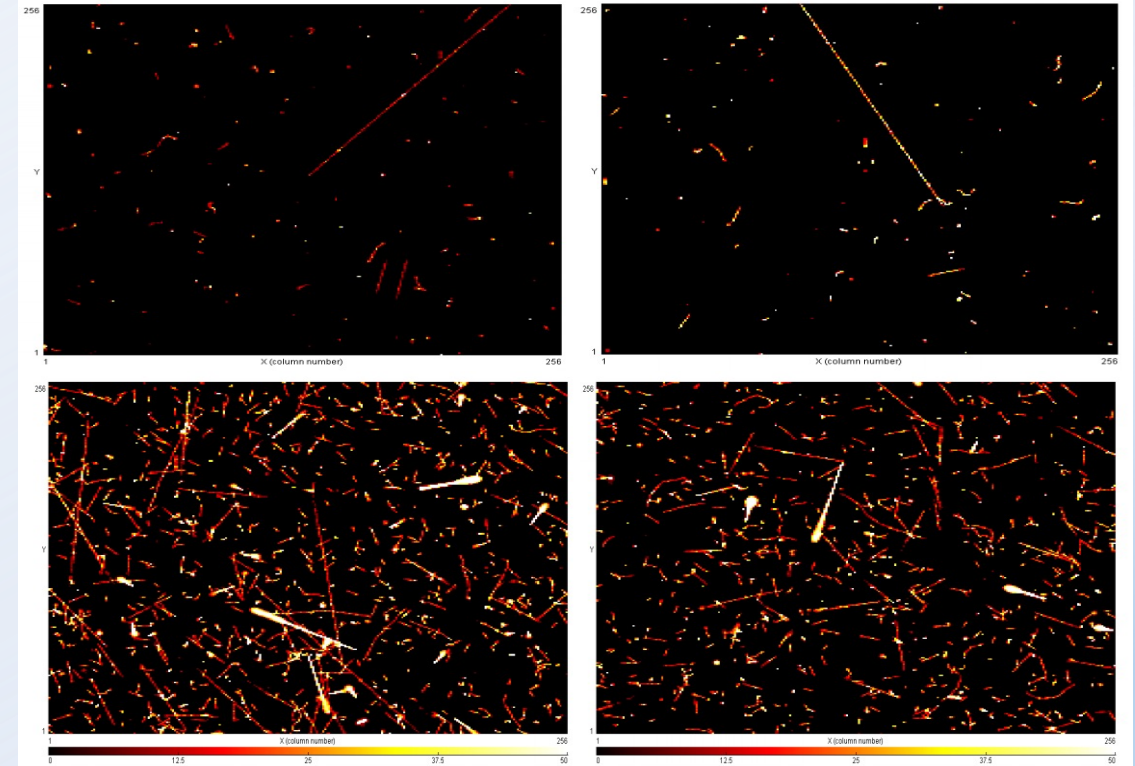

Visualization of different read out frames from data taken at LHC at low and high Luminosities. As the number clusters increase in a single readout frame at high Luminosity, the cluster overlapping takes place.

Correction Methodology:

- Choose some frames from ATLAS data that have low occupancy (To make sure that clusters are not overlapping in these frames).
- Keep adding the frames on top of each other (by giving them same timestamp) and run the clustering software at each step.
- Plot original number of clusters against the number of clusters that are counted by the clustering software.
- Calculate the correction factors. Fit the data.
- Graphs on the right show the percentage difference between LUCID and TPX Luminosity measurements before and after the application of methodology explained above.

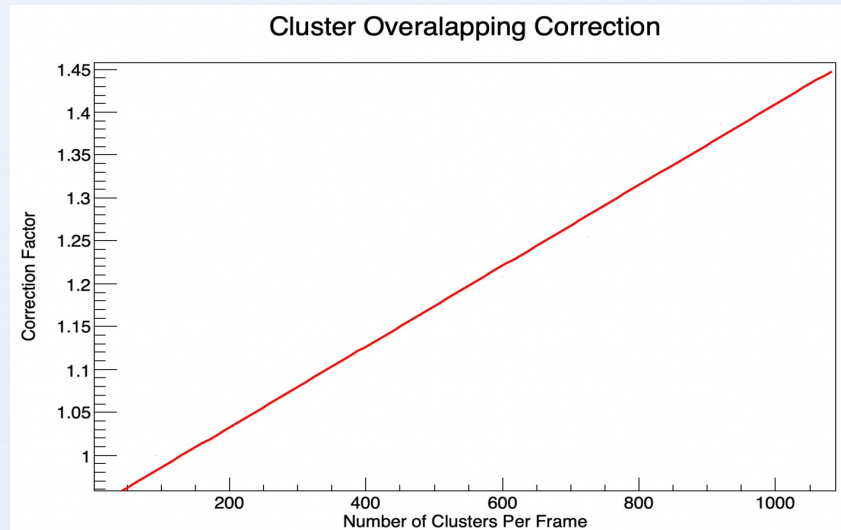

Correction factor as a function of the number of the clusters

