

TRIUMF's Canadian Centre for quantum & precision measurements

We identify 2 major shortcomings for quantum and precision (Q&P) work at TRIUMF

- (1) lack of scientific exchange between Q&P experts across different TRIUMF departments and across the country; there is a large opportunity for knowledge gain from cutting-edge AMO / quantum labs to accelerator facilities
- (2) lack or too small availability of support personnel, resources and laboratory space to pursue Q&P work effectively

TRIUMF's Canadian Centre for quantum & precision measurements

Example 1: RadMol

- entirely novel, multidisciplinary research field which requires scientific expertise from fields which are usually not working together (RIB science, AMO precision experiments, quantum chemistry, particle physics phenomenology, AMO & nuclear theory, etc.)

⇒

critical to connect existing excellence within Canada (and international) to

- ➔ build strong collaboration and
- ➔ to master the technical and scientific challenges when translating AMO precision techniques to rare isotope science (short $T_{1/2}$, small sample sizes, temperature, etc.)

- requires development of novel experimental techniques 'from scratch'

⇒

TRIUMF-local technical support and resources indispensable

- ➔ cryogenics, electronics, DAQ, laser systems, mechanical design, hardware control (EPICS integration), gas and cryogenic handling, detectors, etc.
- ➔ cannot afford to reinvent the wheel on established techniques; need to focus on the truly novel experimental challenges
- ➔ we face these challenges already now, e.g. lack cryogenic designer!

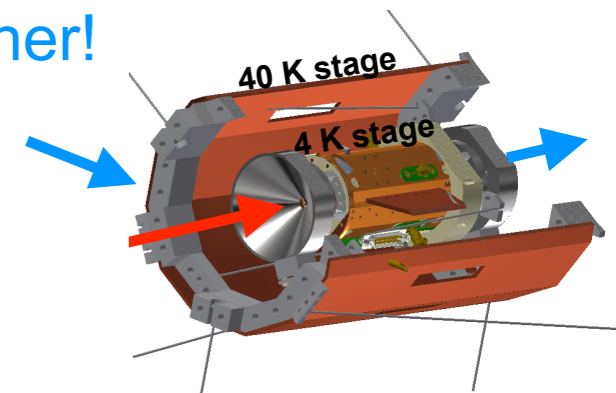

Q&P centre will provide solutions to both

TRIUMF's Canadian Centre for quantum & precision measurements

Example 2: HAICU-ALPHA

- ALPHA is interdisciplinary; essentially an atomic experiment which uses techniques from different fields (tracking detectors, AI/Machine learning, lasers, microwaves, precision clocks, cryogenic, vacuum, ion & atom traps, superconducting magnets ...)
- HAICU aims to develop modern quantum techniques for antimatter using hydrogen as proxy; **also provides opportunities to advance hydrogen and other physics (muonium, tritium, molecules etc)**
- **Enhanced TRIUMF support and expertise would be valuable:**
 - ➔ **Experimental space!**
 - ➔ **Expertise in cryogenics, Mechanical, Laser, Microwaves, Magnets, VUV Photon detection. Ion detection...**
 - ➔ **Also traditional areas: detectors, DAQ, software, Monte Carlo, Machine learning...**

TRIUMF's Canadian Centre for quantum & precision measurements

Example 3: PIONEER (nEXO)

- PIONEER is a major new experiment addressing emerging SM anomalies in flavor physics. It will contribute to augmenting the TRIUMF science program in precision physics.
- Particle physics experiments using emerging technologies (LGADs, VUV SiPM, LXe etc) and **has needs overlapping with several fields for: fast timing detectors, high energy resolution calorimetry , LXe light detection, noble gas purification, cryogenic**
- Enhanced TRIUMF support and expertise would be valuable for:
 - ➔ Pooling of infrastructure and knowledge for Silicon detector testing and characterization (including in LXe)
 - ➔ Framework for sharing existing or future infrastructures
 - ➔ Long-term sustained technical expertise in VUV light detection, cryogenics etc.
 - ➔ Development and operation of cryogenic apparatus for testing, prototyping etc.
 - ➔ Space for hosting common infrastructures & new detector developments
 - ➔ Knowledge sharing in other fields: detectors, DAQ, software, Monte Carlo, Machine learning...

TRIUMF's Canadian Centre for quantum&precision measurements

A centre for quantum&precision (Q&P) measurements will overcome both short-comings

(1) lack of scientific exchange between Q&P experts across different TRIUMF departments and across the country

⇒

establish platform to connect the Canadian (and international) researchers in quantum and precision experiments in fundamental science

(2) lack or too small availability of support groups, resources and laboratory space to be shared between different projects to pursue Q&P work effectively

⇒

provide common space, relevant expertise and resources to be shared among Q&P projects for their successful&effective advancement

TRIUMF's Canadian Centre for quantum & precision measurements

Q&P centre as platform for connecting Canadian (and international) researchers in quantum and precision (Q&P) experiments in fundamental science with the goals of

- strengthening the communities & cross-fertilisation
- identify, help and support in founding and funding of new initiatives in the field of Q&P
- complement (Canadian) quantum initiative in the fundamental sciences
- help to identify synergies and collaboration
- transfer knowledge from cutting- edge AMO / quantum labs to TRIUMF for larger-scale Q&P experiments
- connect in-house expertise at TRIUMF, currently spread over different departments
- promote Q&P work within TRIUMF and Canadian science landscape to TRIUMF and Canada (“common Q&P voice” across different fields, researchers, and institutions)
- at TRIUMF and in the larger Canadian landscape: ensure continued resources in this field in science and operation (in particular hires - also joint appointments with universities: several universities want to “invest” in this field)
- having common experimental & office space including support personnel

TRIUMF's Canadian Centre for quantum & precision measurements

These goals are achieved through

- P&Q seminar series at TRIUMF
- organisation of Workshops and Schools to connect different researchers and field
- availability of funding and support for
 - ➔ workshops; kick-off meetings; first collaboration meetings, etc.
 - ➔ to hire personnel to explore a new idea
 - ➔ seed funding for new initiatives (e.g. CFI contribution)
- connect to TRIUMF management and other decision makers
- provide and host library of resources for experimental techniques adapted to Q&P work
e.g. code library to operate standard equipment, design library, etc.
(‘avoid to reinvent the wheel within each research group or project)
- Specific building space dedicated to the field and dedicated technical personnel (in collaboration with existing S&T department): laser, cryogenics etc (cf Detector Initiative as well)
- establish and operate ‘metrology laboratory’ at TRIUMF (e.g. frequency comb.)

TRIUMF's Canadian Centre for quantum & precision measurements

P&Q possible synergies with other fields

- Detectors: photons, charged particles, cryogenic operation
Combine with detector development center?
- Positronium at ARIEL?
- Neutrinos: direct mass measurement with tritium?
- CMMS: beta-NMR, muonic atoms, muonium physics
- Accelerators: ARIEL THz source, Laser ionized RIB source, advanced magnets, power supplies, superconducting RF, cryogenics, vacuum
- “Benefits to Society”, e.g.
 - ➔ Quantum sensors, e.g. diamond NVC magnetometers
 - ➔ Quantum information: e.g. quantum logic spectroscopy
 - ➔ New lasers & microwave systems
 - ➔ New type of magnets
 - ➔ New frequency standards: e.g. optical clocks
 - ➔ Air, water monitors (Fabrice, Akira)

TRIUMF's Canadian Centre for quantum & precision measurements

Why a Q&P centre is good for TRIUMF:

- boost for existing and planned Q&P projects to lead internationally
- accumulation and sustainability of skills, knowledge and expertise
- release general pressure on space and resources at TRIUMF
- provide expertise and resources for Q&P at universities
- TRIUMF visibility to the public in 'Quantum Science'

!!! THIS is the TIME !!!

if we don't initiate this now, the opportunity might be lost

(if we wait until FYP2030-35, such a centre will no longer be competitive internationally)

TRIUMF's Canadian Centre for quantum & precision measurements

Structure?

- rather not a new TRIUMF department
- but platform to connect people from different platforms
- Board with rotating chair ?
- with representation of management