

# Feedback From SRF Operations at JLAB

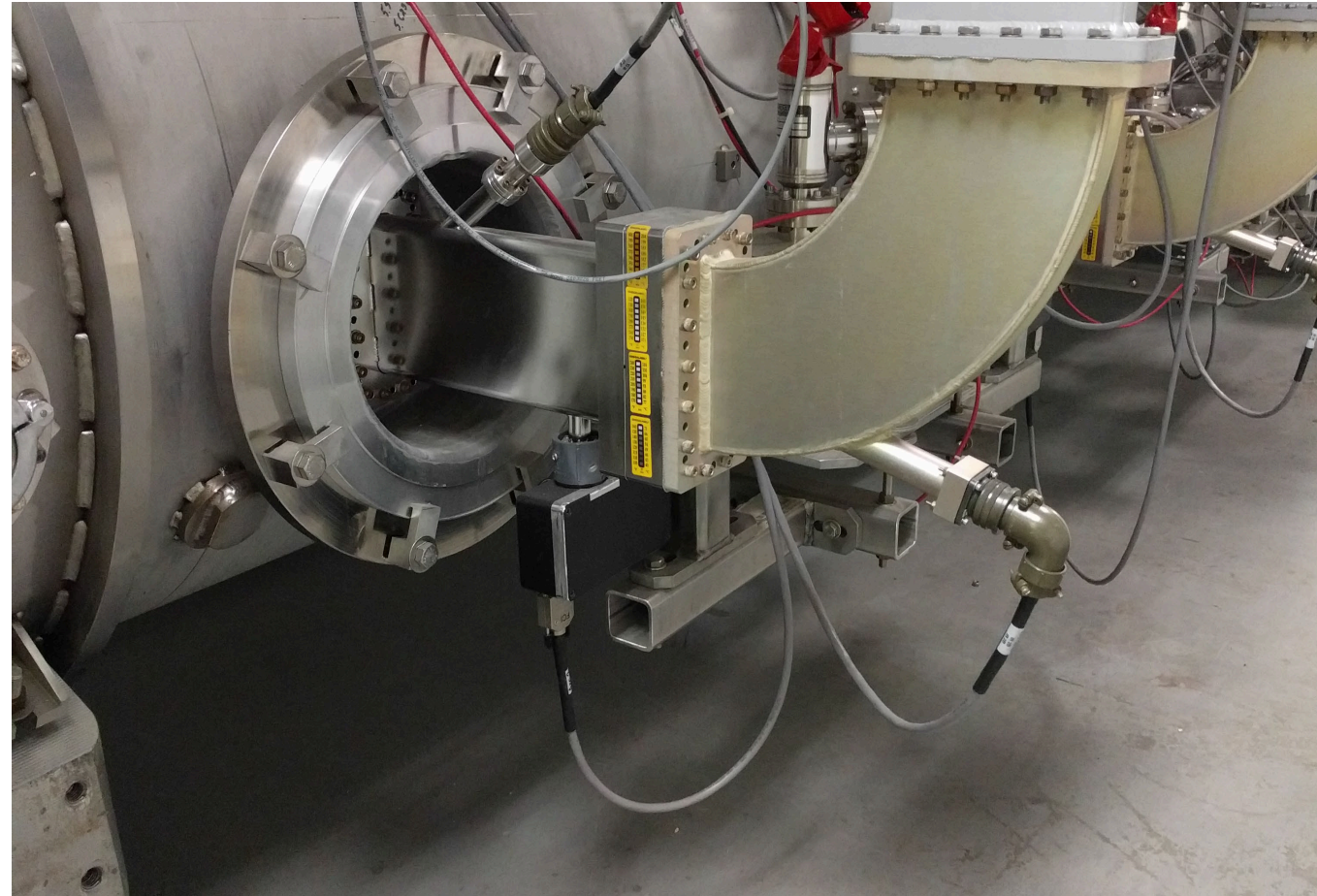

**Tom Powers**

eLinac Reliability Workshop

9 May 2022

 Jefferson Lab

## Cryomodule Interlocks

- **NEVER OPERATE A CRYOMODULE WITH HIGH POWER RF AND THE COUPLER INTERLOCKS BYPASSED ! ! ! !**

- **Coupler Interlocks**

- Arc detector(s)
- Coupler vacuum
- Window temperature
- Water flow (If water cooled)
- Electron probe (Useful but not required)
- Water temperature (Useful but not required)

- **Cryomodule**

- Cavity vacuum
- Helium level
- Helium pressure (Useful but not required depending on cryo plant)
- Insulating vacuum (Useful but you only look at it after you find out that you can not maintain liquid level.)

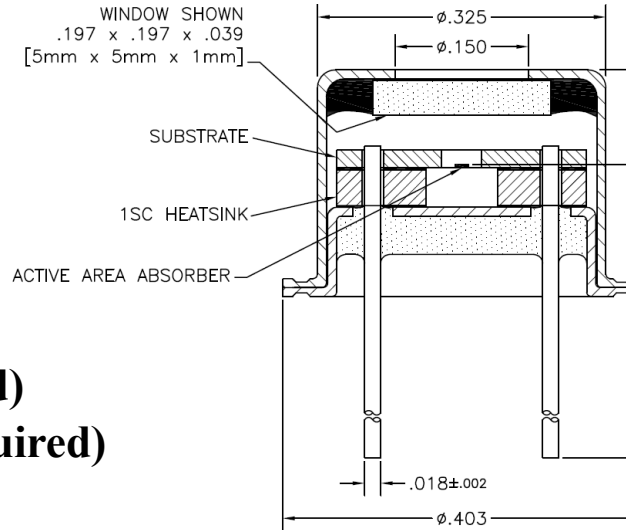

**Thermopile detector used as temperature monitor**

Reference from TTC-2019 held at Triumf which has details from other labs, T. Powers Talk on Coupler Interlocks  
[https://indico.desy.de/event/21337/contributions/42635/attachments/27293/34392/TTC\\_Feb2019\\_coupler\\_Interlocks\\_tjp1.pdf](https://indico.desy.de/event/21337/contributions/42635/attachments/27293/34392/TTC_Feb2019_coupler_Interlocks_tjp1.pdf)

## Coupler, RF windows, etc. should be tested at full power as part of production

- A coupler failure that vents the coupler vacuum but not the beam line vacuum means that you will lose the ability to use that cavity for days or months and will shut down your machine for at least a few day. Be prepared with a plan and hardware for blanking off a failed coupler.
- A coupler failure that vents the beamline will probably take your machine down for months and you can expect to have substantially degraded performance in that cryomodule forever.
- My experience is that failure that involves a catastrophic beam line vacuum failure will degrade the usable gradient by 30% to 50%.

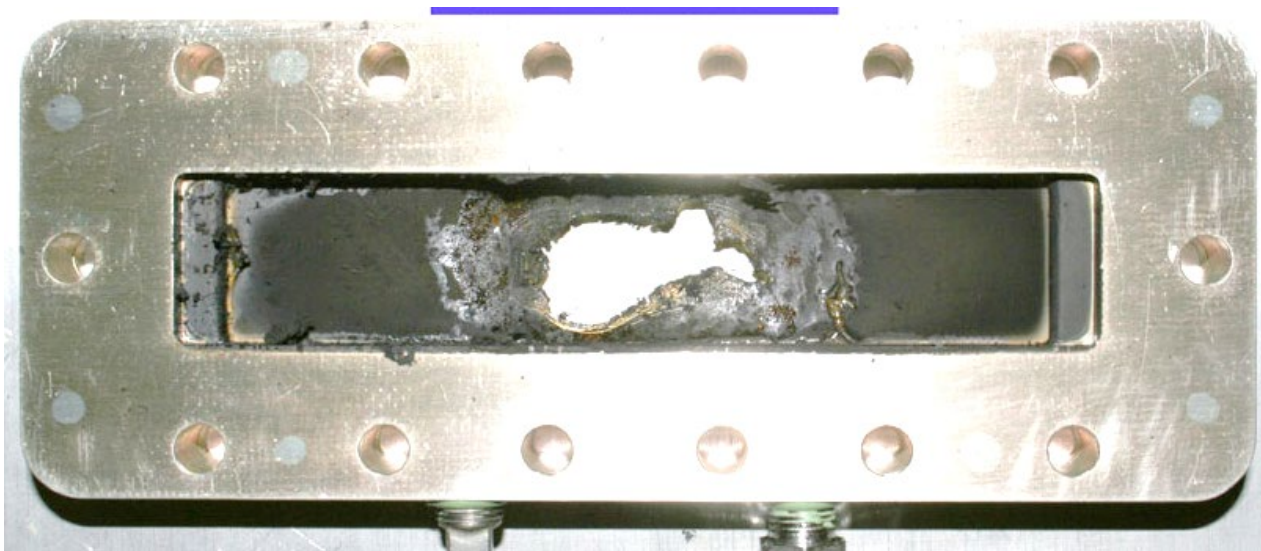

**Rexolite window that was operated with no interlocks. It was tested to 12 kW in a vertical configuration but installed horizontally Trapped gas due to horizontal placement caused failure at power much less than 12 kW**

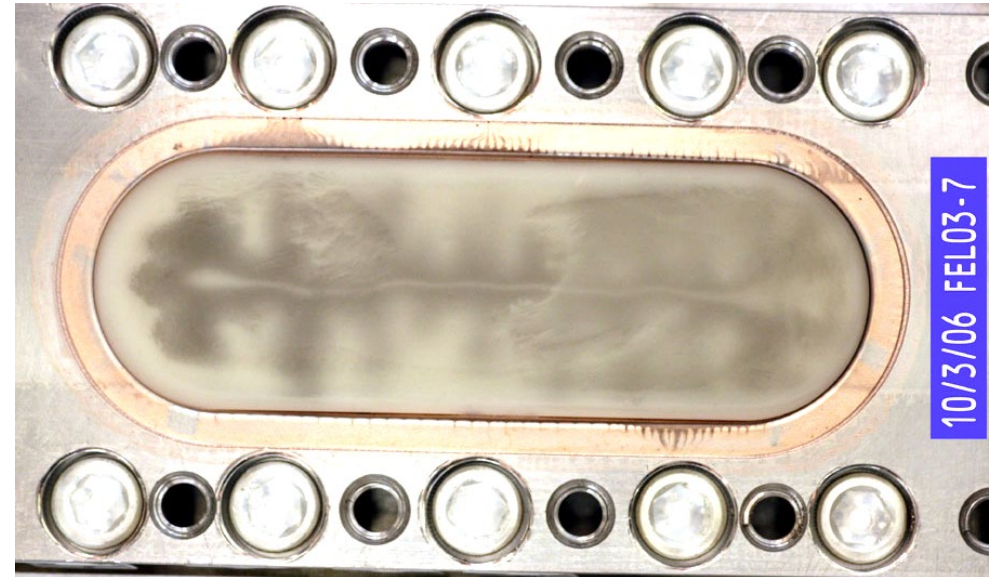

**Ceramic window with soot embedded from the same event. After checking with an IR camera and RF we continued to use the cryomodule for 14 Years before it was rebuilt.**

# Quench Protection

- Quench protection has to be done in the RF system.
- Machines with a loaded-Qs below  $10^6$  a quenched cavity can become an exciting event as excessive power can be deposited into the helium bath. For example at SNS a quenched cavity can put on the order of 10 kW average power into the bath.
- Two types of interlocks.
  - During normal operation look for an unexplained reduction in gradient 10% or 15% is enough but by then the RF system has probably already tripped for other reasons.
  - In self excited loop mode look for a cavity that has a very low gradient and “excessive” difference between forward and reflected power. This may require that you “calibrate” the reflected power by turning the RF on in tone mode with the cavity “detuned.”

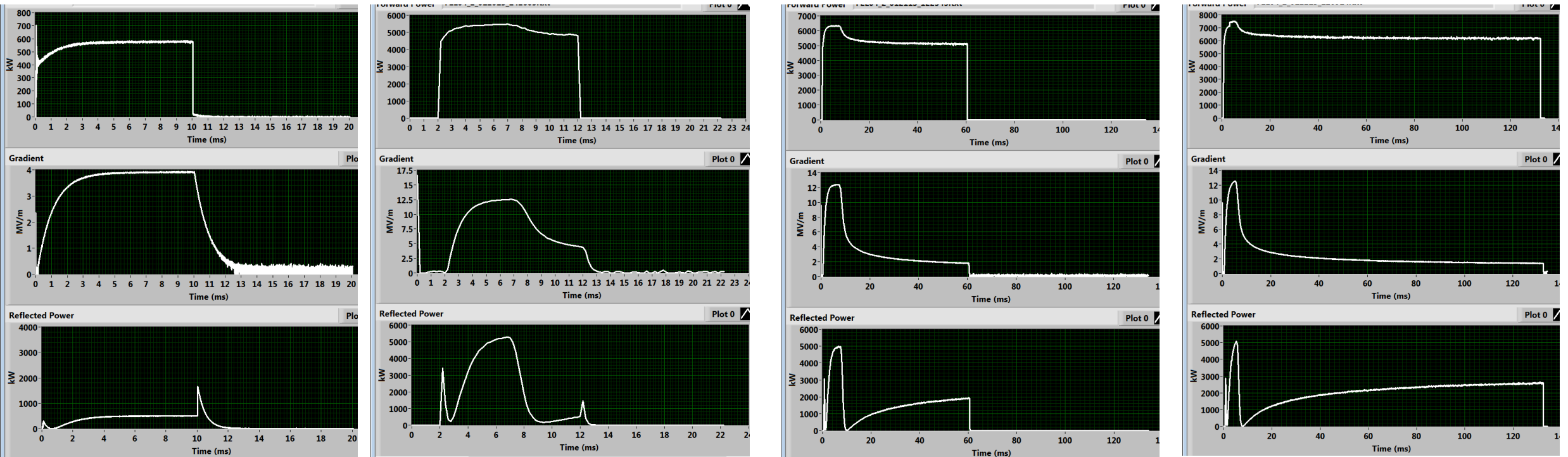

Normal pulsed operation

Partial quench during 10 ms pulse

Quench during 60 ms pulse

Quench during 130 ms pulse

All data in fixed input power frequency tracking mode (SEL mode)



## Other events that lead to quenched cavities

- During normal operations one determines the prompt quench field of each cavity and sets up the maximum gradient to slightly less than that gradient. At JLAB we use an 0.5 MV/m margin.
- For cavities with conduction cooled end groups like ILC, LCLS II, and JLAB C100 cavities
  - End group heating effects with long time constants can lead to cavity quenches.
  - These quenches can take a few hundred milliseconds to seconds build up in the cells once the end group quenches.
- Sometimes cavities will trip for a different reason and end up quenched
- Sometimes transients in the RF controls can lead to quenches by accidentally driving a cavity up to its prompt quench value.
- For a closed loop CW system it can be difficult to tell if it was really a quench.

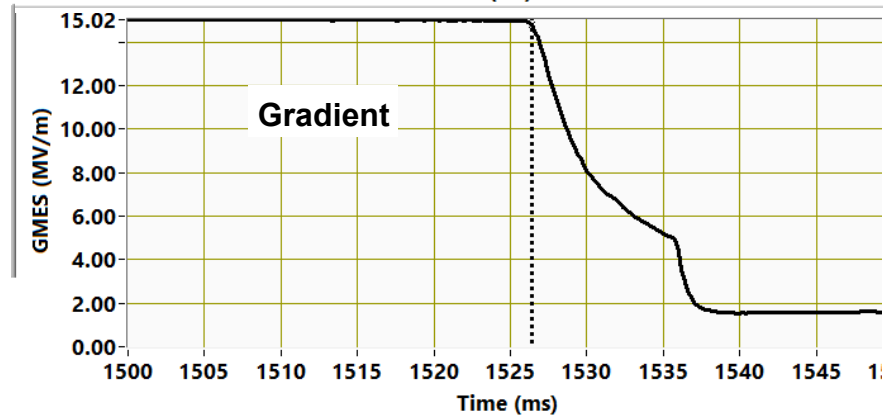
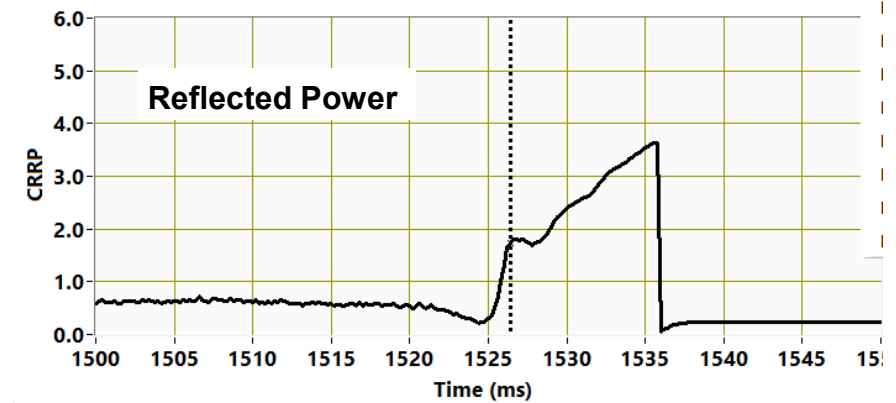
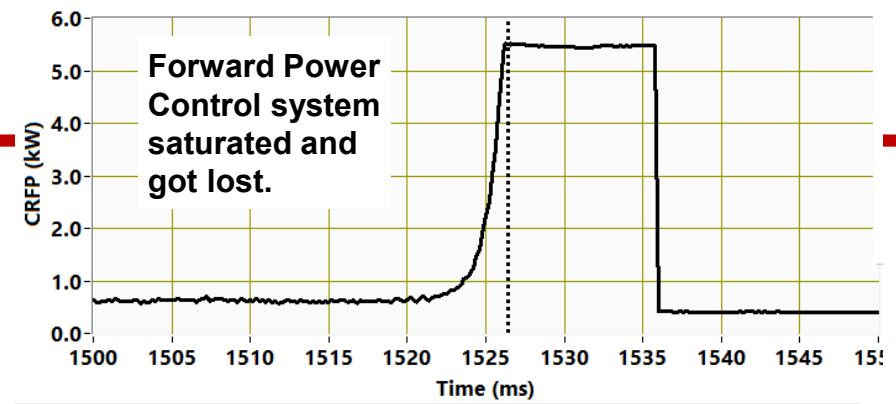
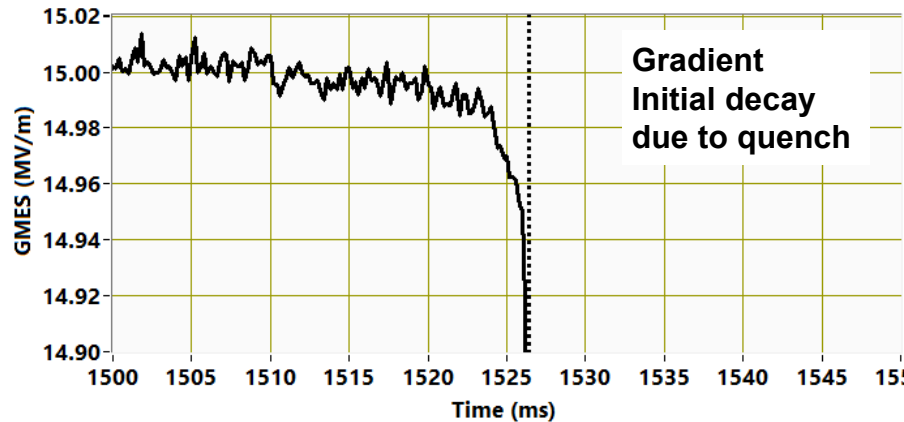

System with closed loop gradient and phase control. The cavity stayed quenched in SEL mode until the RF was turned off.

# Sources of Energy Jitter

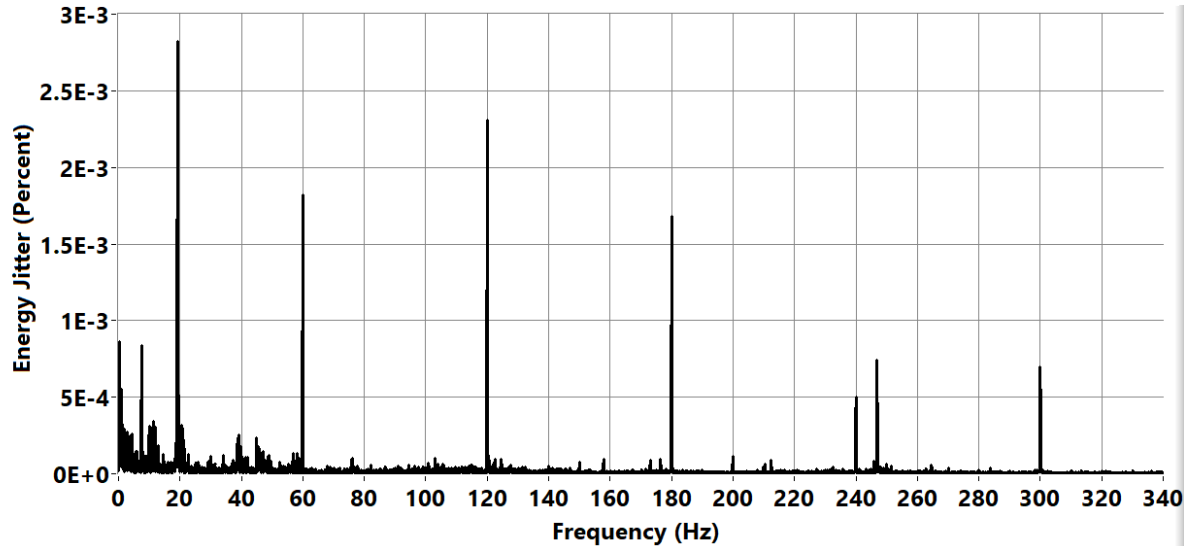

## CEBAF Injector 18 cavities

- 10 Hz and 20 Hz and 40 Hz due to microphonics in the C100 cryomodule which provides 77% of the injector energy.
- 10 Hz half of the cavities go up in frequency while the other half go down thus they cancel somewhat.
- At 20 Hz half the string goes up and down synchronously. However, each half of the string has a slightly different frequency and magnitude.
- 40 Hz individual cavity modes are all slightly different.
- Line harmonics are from the ripple in the 5 kW and 8 kW klystron power supplies which are 12 phase SCR supplies.

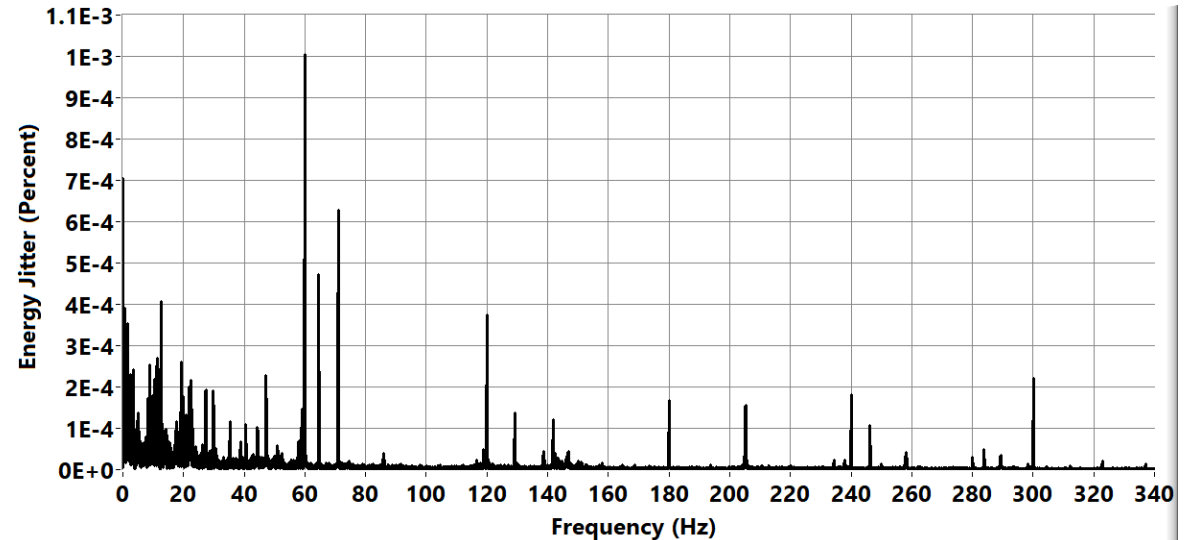

## Hall A beamline multipass beam appx. 400 cavities

- 9 Hz through 50 Hz are modes from the C100 cryomodules each cryomodule is at a slightly different frequency.
- Line harmonics are from the ripple in the 5 kW and 8 kW klystron power supplies. The line harmonic energy jitter was there before the C100 cryomodules were installed.
- Line harmonics addressed using an energy and position “fast” feedback system.

**Cavity feedback control systems can only reduce gradient and phase errors by a finite amount.**

# Field Emission: Particles found in a cavity after appx 8 years in CEBAF

Steel – EDS Spot 3

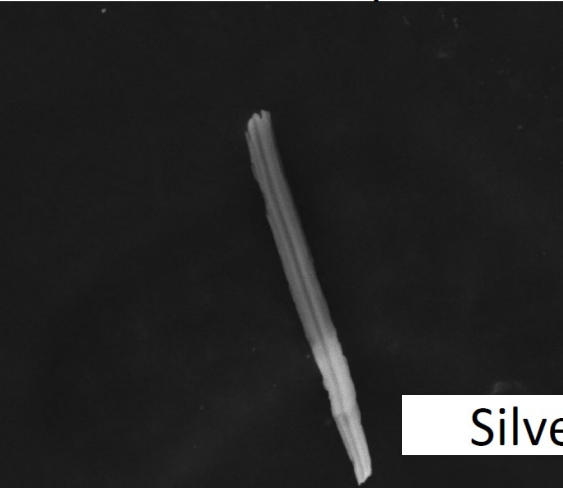

- Even if you start out with clean cavities particles “migrate” into the cavities during operations.
- We are now doing all inter-cryomodule beam line (known as girders) assembly in the clean room with the same care as cavity strings.
- We switched to two-compartment clean rooms for any girder beam line work in the tunnel.

Copper – EDS Spot 2

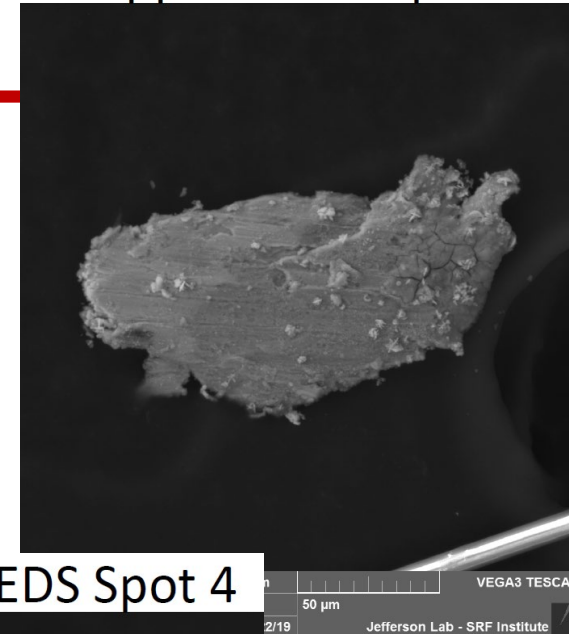

Silver – EDS Spot 5

SEM HV: 30.0 kV WD: 17.21 mm  
View field: 150 µm Det: SE 20 µm  
SEM MAG: 1.84 kx Date(m/d/y): 02/22/19 Jefferson Lab - SRF Institute

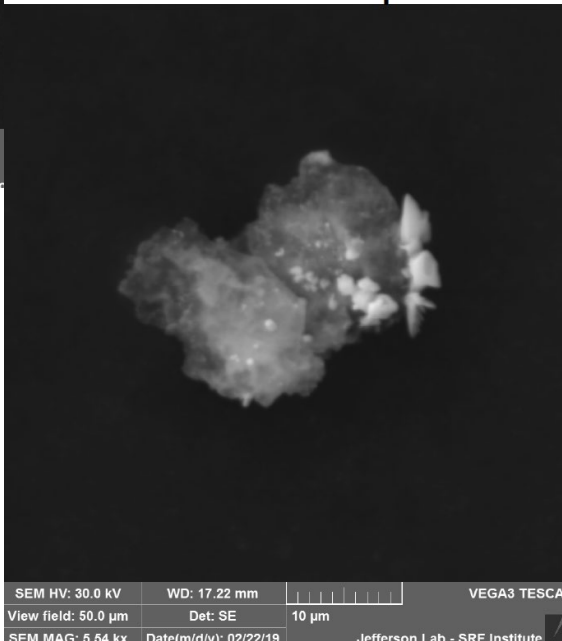

Fiber – EDS Spot 8

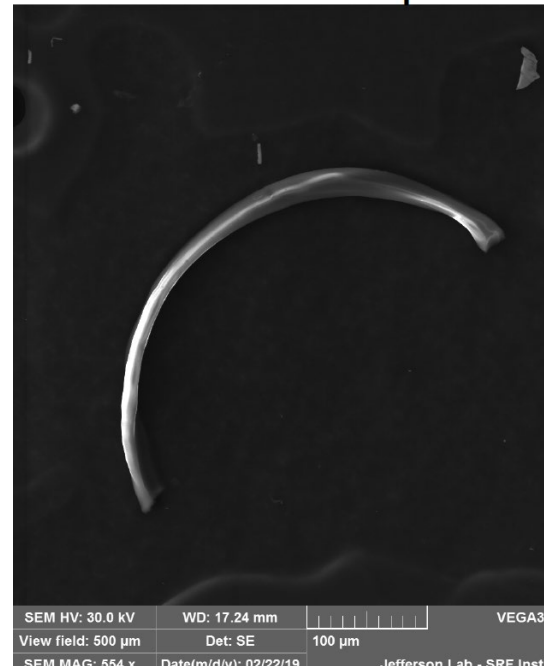

Titanium – EDS Spot 4



Reece et. al. SRF2019 <https://doi.org/10.18429/JACoW-SRF2019-WETEB2>

# Radiation Damage

## JLAB Free Electron Laser

- In the JLAB FEL days we optimized the cryomodule operating voltage for maximum voltage with radiation levels in the linac of 1 R/hr. (0.01 Sv/hr) This was done to protect the wiggler magnets. For this reason we had no problem with radiation damage.

## CEBAF

- We have to push the cavities harder in order to make the energies required by physics. There is a program to rebuild and upgrade cryomodules to increase the field emission free gradients and increase our energy margin.
- For years there was little regard for radiation levels around the cryomodules and measured dose rates on the order 1 kR/hr (10 Sv/hr) were not unusual. These levels led to damaged hardware, mostly the wiring in the girders but eventually cryomodule hardware.
- More recently we installed neutron/gamma detectors between the cryomodules and we optimize the gradients to reduce the neutron dose. Pavel Degtiarenko NDX: Neutron Dose Rate Meters with Extended Capabilities, <https://zh.booksc.eu/dl/83212566/99046b>

## CEBAF Beamline Valve Failures

- In addition to multiple valves that developed leaks over the years we had two valves that had catastrophic failures after about 10 years of operation in high a radiation environment.
- In both cases the two cavities adjacent to each valve could no longer be operated.
- Reprocessing the cavities from these cryomodules was problematic and required that they be electropolished.



Normal Valve

eLinac Reliability Workshop 9 May 22, T. Powers



Valve from CM 1L25

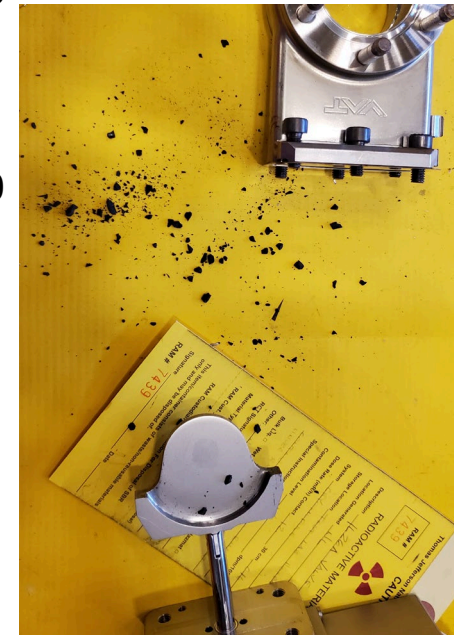

Valve removed from CM 1L26

Jefferson Lab



# Field Emission Mitigation

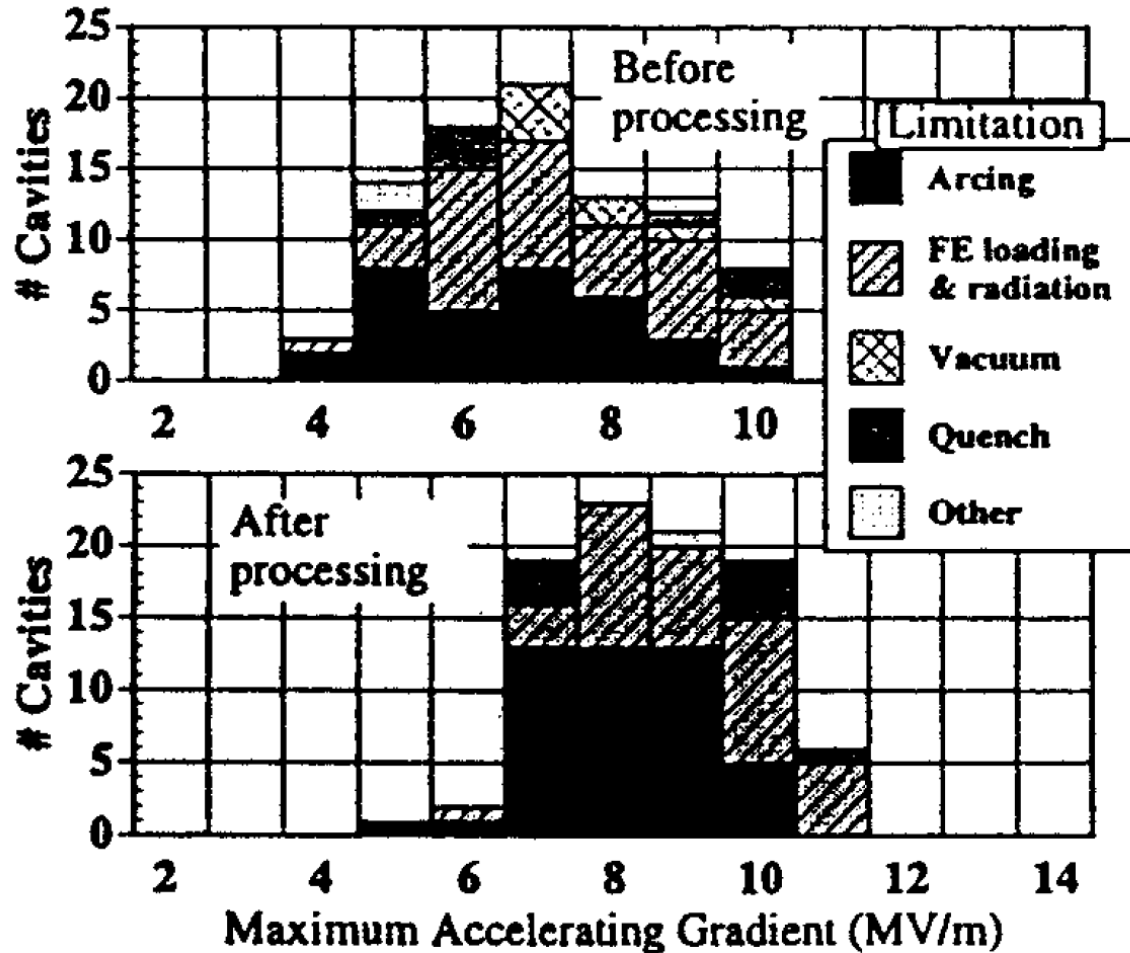

Helium processing was performed after an uncontrolled warmup of CEBAF due to hurricane Isabel. Reece, et. al. Pac 2004

## Helium Processing\*

- 2K processing followed by 30K thermal cycle
- Helium gas at  $4e-4$  Torr
- Process cavity to quench working increasing the gradients up. Typically 4 hours per cavity
- Using the same level of RF power as normal operation
- Mechanism ion bombardment of FE particles
- Typical improvement 1 MV/m per cavity
- We still helium process cryomodules on occasion but have not done a large number during a given maintenance period since 2004.

# Field Emission Mitigation

SNS Improvement in Operating Gradient After Plasma Processing Average 2.5 MV/m, N=32

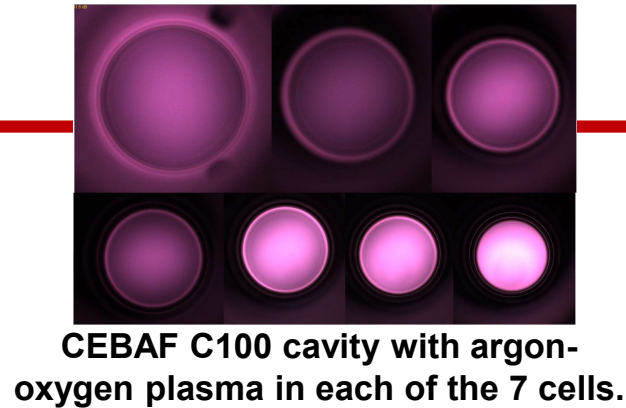
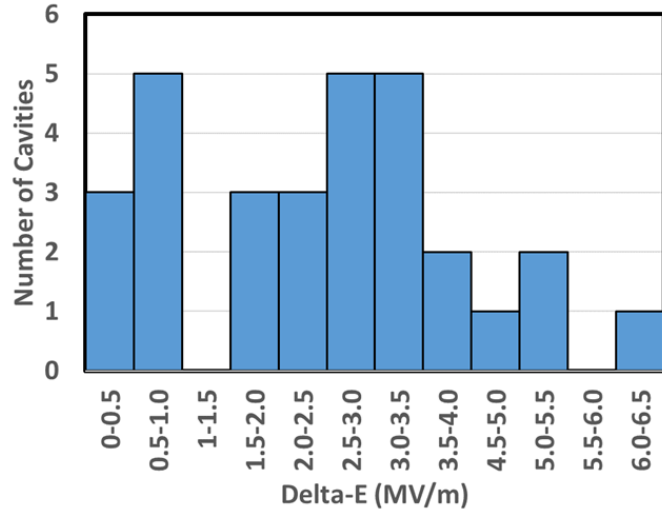

CEBAF C100 cavity with argon-oxygen plasma in each of the 7 cells.

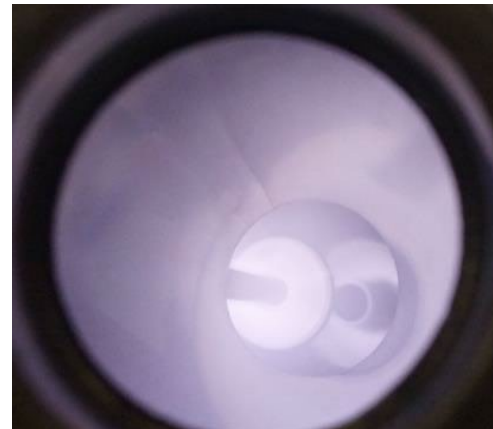

WiFEL Gun with He/O<sub>2</sub> plasma

## Plasma Processing

- Room temperature processing with a mixture of a noble gas and oxygen.
- Pressure between 0.05 and 0.25 Torr
- RF power 15W to 400W depending on cavity and gas
- Mechanism: Free oxygen breaks down hydrocarbons on the surface which increases the work function and decreases the secondary emission coefficient.
- Example improvements
  - SNS average 2.5 MV/m out of 36 cavities to date. (M. Doleans)
  - WiFEL SRF gun cathode fields improved from 6 MV/m to 26 MV/m. (B. Legg)

Review Paper M. Martinello, et.al., SNOWMASS, <https://arxiv.org/abs/2203.12442>

C100-86 16 Nov 21, 8, 15, 22 Apr. 2022, After Last Round of Processing, Then Methane/Argon Plasma, then 1% O<sub>2</sub> Processing, Then Processing With Experimental Gas Mixture

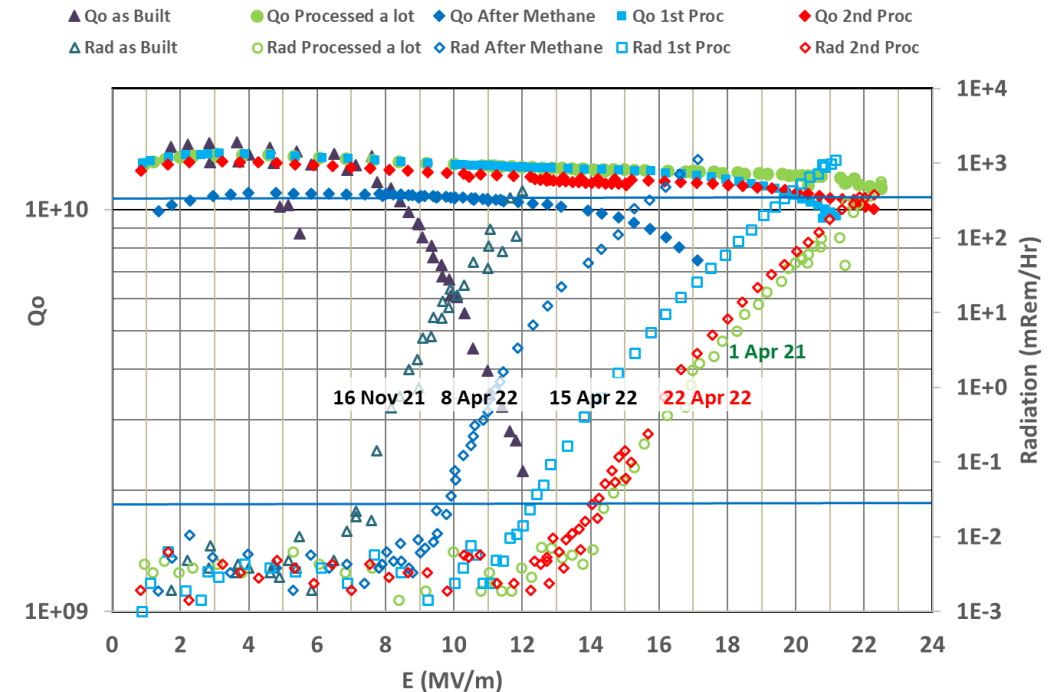

## JLAB recent vertical test results

- FE onset out of the clean room 7.5 MV/m
- Processed several times the last time with a new gas mixture to get to the 1 April results (Green) FE onset 14.7 MV/m
- Methane plasma used to deposit hydrocarbons on the surface and reset the FE onset to 10 MV/m
- Plasma using 1% oxygen and experimental gas mixture used in order to repeat the results of FE onset at 14 MV/m
- FE at operating gradient of 18 MV/m improved from >1 Rem/hr to less than 0.008 Rem/hr.

We plan on processing a cryomodule in the test lab prior to it being rebuilt in about 3 weeks.

# JLAB IR and UV FEL

- 3 cryomodules with 8 cavities and an 2 cavity injector cryomodule.
- Analog monitoring system and video switching system, allowed us to monitor the health of the RF systems and beam properties.
- RF systems, magnet power supplies, and most diagnostics were copies of the original CEBAF hardware.
- RF systems, 24ea 8kW klystrons (linac), 1ea 2 kW klystron (buncher) and 2ea 100kW klystrons (injector)
- The system was decommissioned about 7 years ago. The injector and one cryomodule still exists as does most of the magnets and associated power supplies.

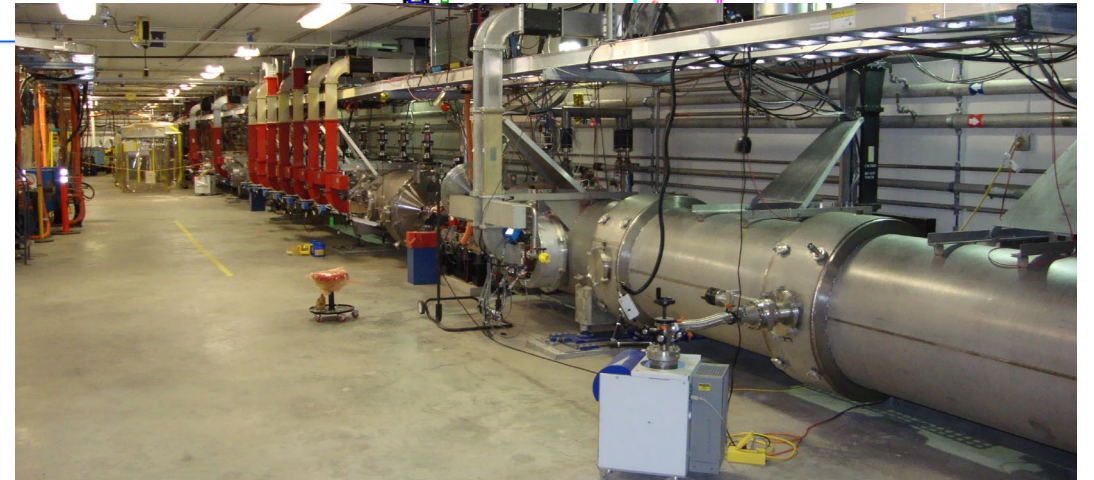
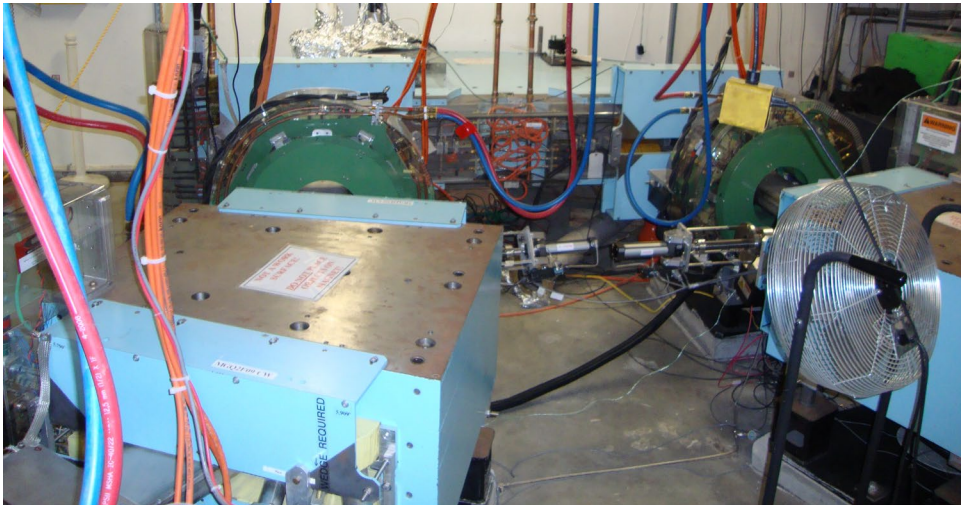
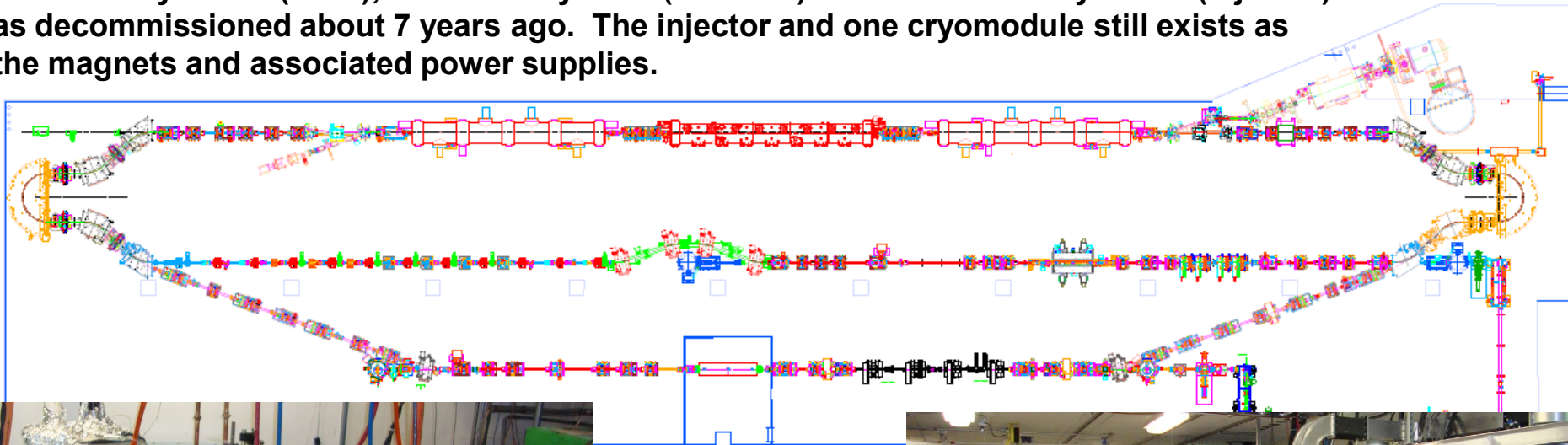

# A week in the life of the FEL when the CEBAF control center is manned

- **Monday 4 to 6 hours from open access to lasing (three to four people)**
  - Sweep the machine (2 sweepers and one safety system operator)
  - Bring the safety system to beam permit
  - Bring the machine up from everything off to lasing
- **Weekday end of shift go to hot standby**
  - Cavities set to 5 MV/m
  - Gun and arc-dipole magnets ramped down to an off state
  - The main control room takes overnight responsibility for the machine
- **Tuesday – Friday less than one hour to restore operation (one or two people)**
  - Ramp up the gun
  - Ramp up and cycle the dipoles
  - Ramp up the SRF cavities
  - Turn on the beam and check the phasing in the injector.
  - Adjust the laser cavity mirrors to establish lasing
- **Friday end of shift**
  - Ramp down the gun and dipole magnets
  - Turn off the SRF cavities and klystron power supplies
  - Survey the machine for activated components
  - Put the machine into open access

**Record for taking the machine from controlled access for a tour to lasing was 15 minutes**

---

**Questions?**

# 0R04 cryomodule 11.5 and 19 Hz and 21 Hz Microphonics

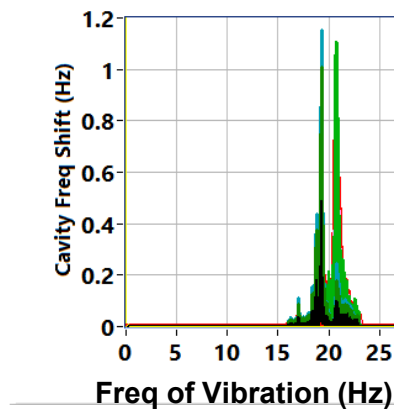
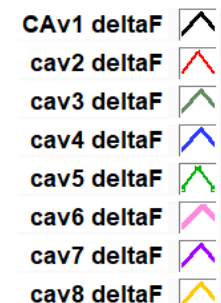
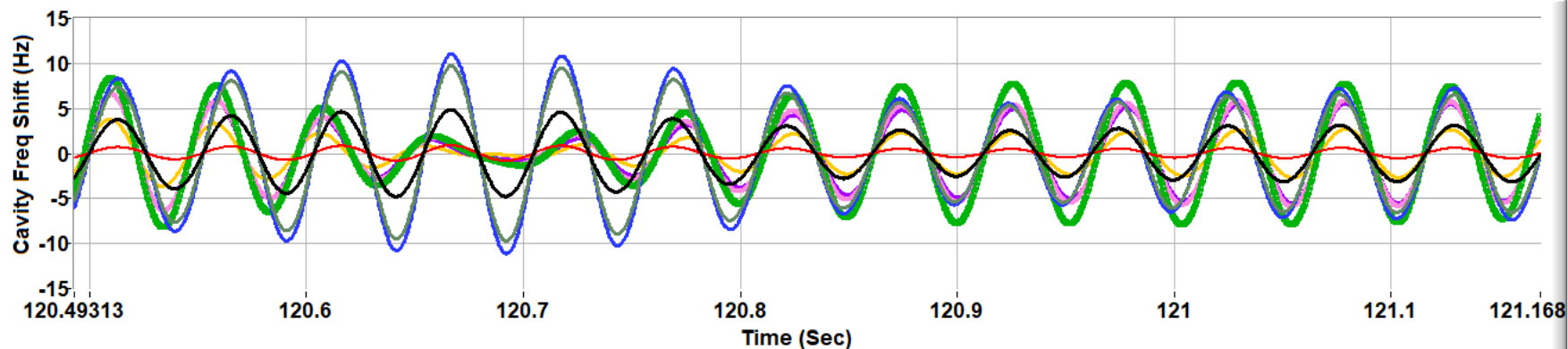
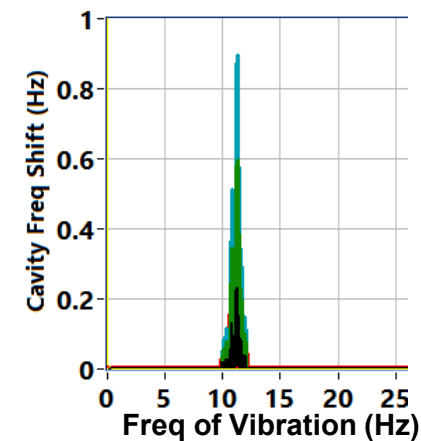
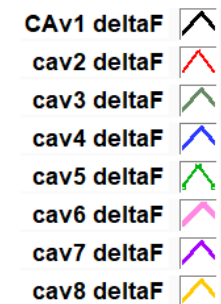
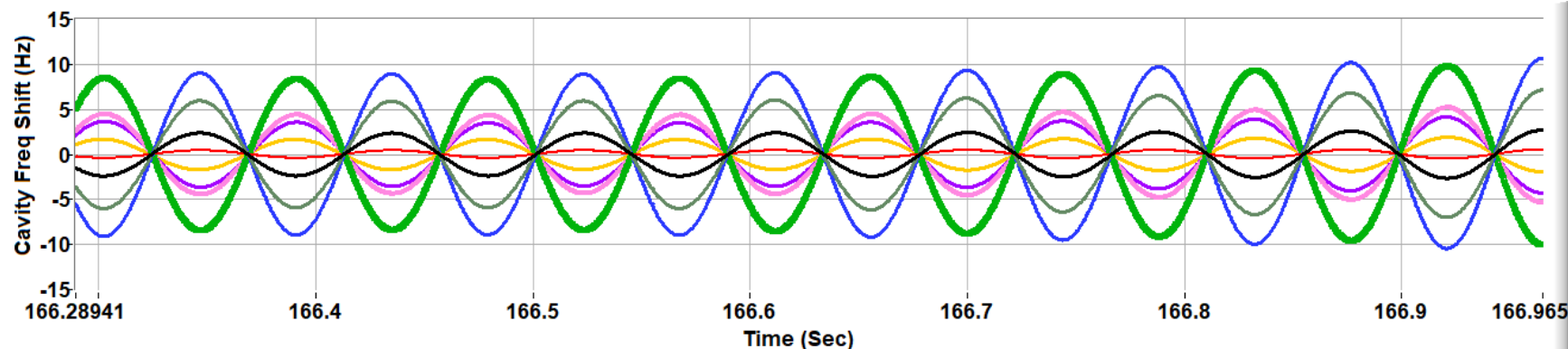

# NDX Detector

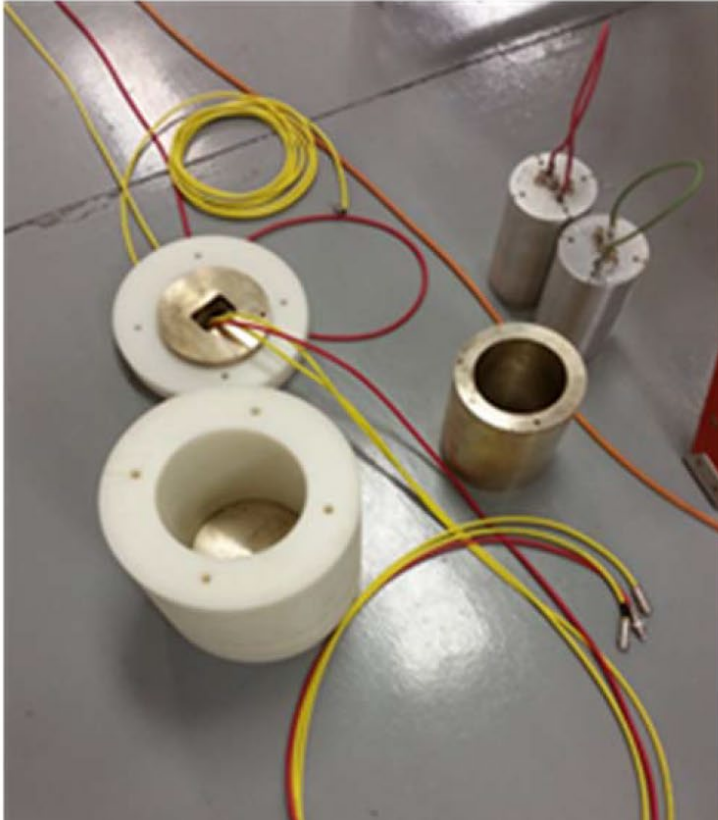

Pavel Degtiarenko NDX: Neutron Dose Rate Meters with Extended Capabilities, <https://zh.booksc.eu/dl/83212566/99046b>