



# Feasibility Study of High Intensity Lithium Beam Production for Directional Pulsed Neutron Flux Generation

Masahiro Okamura

Sep. 18, 2023

ICIS'23 Victoria, BC, Canada





Masahiro Okamura, Shunsuke Ikeda, Takeshi Kanesue, Brookhaven National Laboratory, New York 11973, USA  
Antonino Cannavò, Giovanni Ceccio, Department of Neutron Physics, Nuclear Physics Institute of CAS, Prague, Czech Republic  
Kazumasa Takahashi, Department of Electrical Engineering, Nagaoka University of Technology, Niigata 940-2188, JAPAN



# Why compact neutron generator

After Fukushima incident, almost no plan to build a new research nuclear reactor.

**However**, neutron's demand is increasing for nondestructive analysis and medical field.

- civil constructions (bridge, tunnel, building,,)
- metal manufacturing
- border protection (cargo inspection)
- mine sweeper
- investigations for airplane and train parts (residual stress analysis)
- boron neutron capture therapy (BNCT)

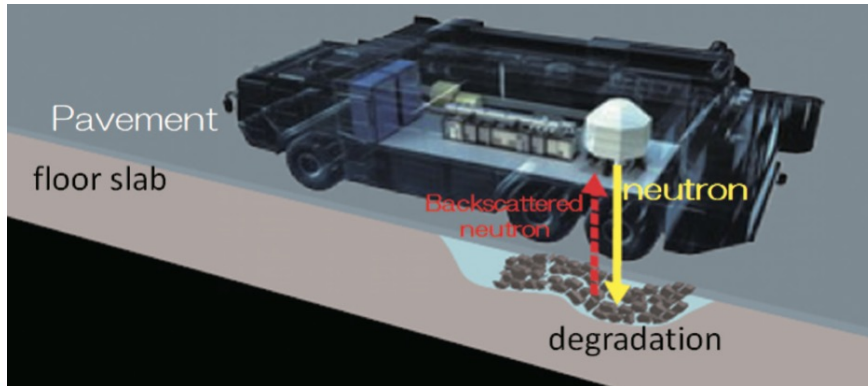

3

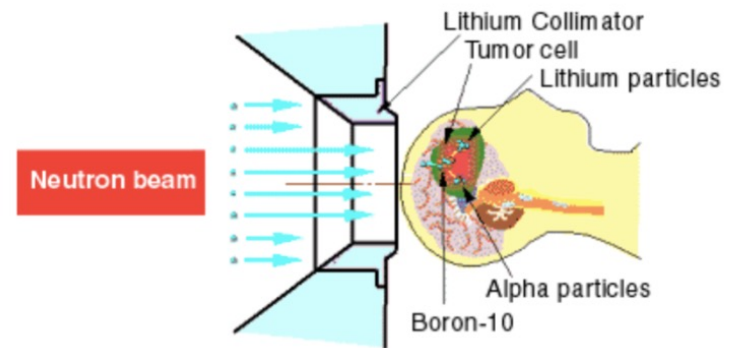

<https://rap.riken.jp/en/labs/aptdg/nbtt/>

<http://www.jaea.go.jp/jaeri/english/press/991025/fig03.htm>

# Background

- Kinematic focusing of neutron is very effective for a compact generator.
  - use **lithium beam** instead of proton beam
- BNL has developed high current highly charged ion source.
  - direct plasma injection scheme (DPIS) ,  
comparable peak current to proton accelerators
  - laser ion source has provided stable beams for more than 9 years
- By combining kinematic focusing and laser ion source,  
a novel **compact neutron generator** can be realized.

# Why lithium beam?

## Neutron yield and driver beam energy

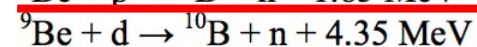
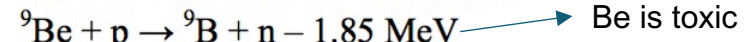
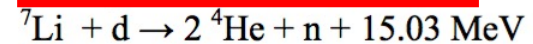
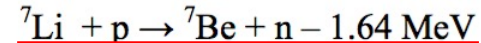
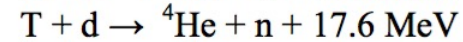
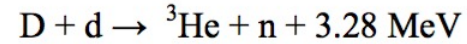
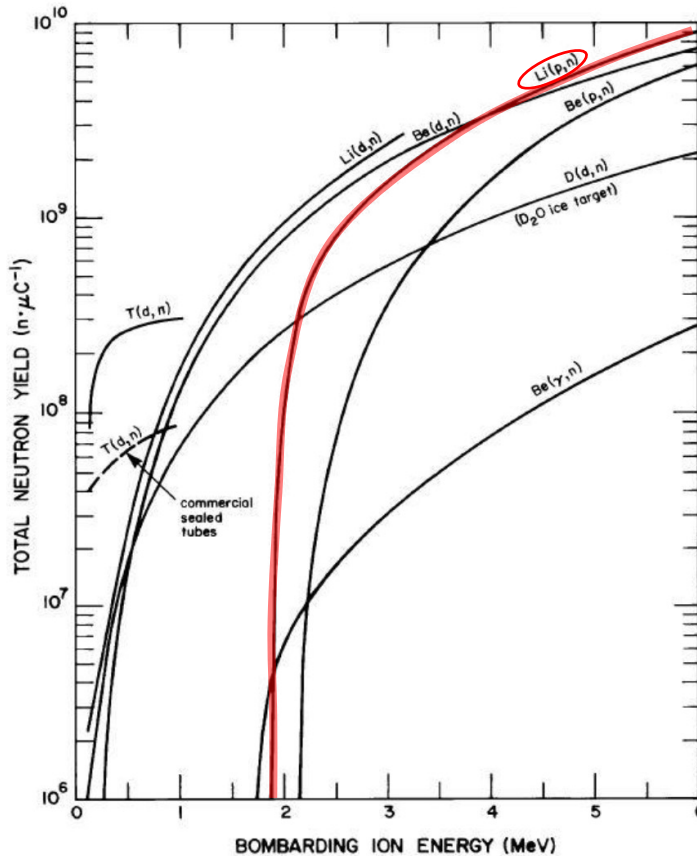

Be is toxic

Endothermic reaction (negative energy emission)

Fig. 1. The thick target neutron yield as a function of bombarding ion energy for various low energy nuclear reactions [1].

Yubin Zuo et al. / Physics Procedia 60 (2014) 220 – 227

# Neutron production with proton beam

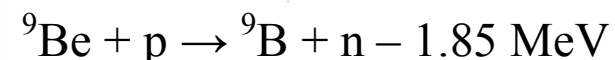
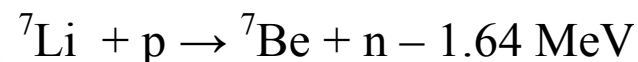
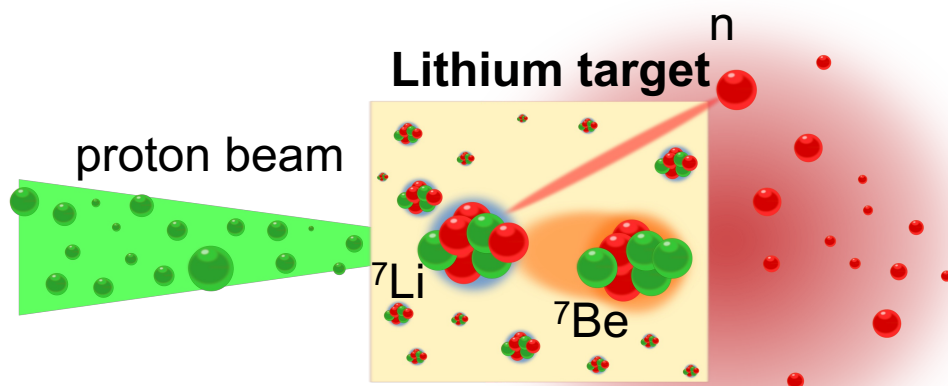

Isotropic neutron production

- These reactions are endothermic and undesired radiations could be reduced if beam energy is near the thresholds.
- However, since the proton is lighter than target atoms, the neutrons are produced almost isotropically and only small fraction can be used.
- Therefore, higher beam energy is used to increase neutron flux. (causing undesired radiations)

# Neutron source with heavy ion driver

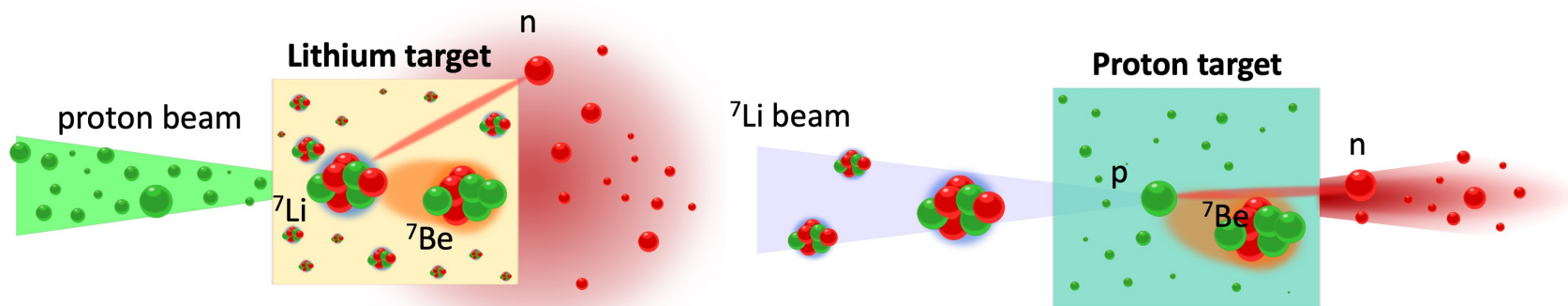

Isotropic neutron production

High directivity neutron

- When heavy ions are delivered, neutrons are directed to forward because of the high gravity center velocity.
- Neutron flux can be increased while beam energy is kept near the threshold.



## Development of a kinematically focused neutron source with the $p(^7\text{Li},n)^7\text{Be}$ inverse reaction

M. Lebois <sup>a,\*</sup>, J.N. Wilson <sup>a</sup>, P. Halipré <sup>a</sup>, B. Leniau <sup>a</sup>, I. Matea <sup>a</sup>, A. Oberstedt <sup>c,d</sup>, S. Oberstedt <sup>b</sup>, D. Verney <sup>a</sup>

<sup>a</sup> Institut de Physique Nucléaire d'Orsay, 15 Rue G. Clémenceau, 91406 Orsay Cedex, France  
<sup>b</sup> Institute for Reference Materials and Measurements, Retieseweg 111, 2440 Geel, Belgium  
<sup>c</sup> CEA/DAM Ile-de-France, 91297 Arpajon Cedex, France  
<sup>d</sup> Fundamental Physics, Chalmers University of Technology, 41296 Göteborg, Sweden

### • Advantage

The kinematic focusing technique clearly offers some distinct advantages over standard isotropic quasi-monoenergetic sources:

1. The focusing enhances the available neutron flux by a factor of between 25 and 100.
2. The lack of neutron emission at most angles results in much lower fast and thermal scattered neutron backgrounds in the experimental hall.

### • Disadvantage

available beam current of  $^7\text{Li}$  is much lower than that available for protons in the non-inverse reaction, because of the relative difficulty of extraction of  $^7\text{Li}$ -ions from the ion source. Secondly,

#### 3.1. Target heat evacuation

For conventional, isotropic neutron sources using the non-inverse reaction solid targets are usually thermally coupled to the beam stop and many tens of Watts of power must be evacuated. Target cooling with a flow of air or water is essential. However, in inverse kinematics the  $^7\text{Li}$  beams have very much reduced power (factor of 100) so the amount of heat to be evacuated from the target is significantly decreased. Therefore, a thermal coupling between target and beam stop is no longer required. With a thermally decoupled target only a few tens of milliwatts will be deposited and thus radiative cooling will be sufficient without large rises in target temperature. For example, 100 nA of  $^7\text{Li}$  on 4.4  $\mu\text{m}$  of polypropylene or 1–3  $\mu\text{m}$  of  $\text{TiH}_2$  leads to a deposited power of 16 mW. The most pessimistic assumption is that the target undergoes a radiative cooling process only. In that case, the temperature depends only on the material emissivity and the temperature at thermal equilibrium can then be calculated. Considering an environment with an ambient temperature of 293 K, for both targets the equilibrium temperature is around 5 degrees higher at 298 K. This value is small compared to the melting point of the target and thus heat generation in the target is not a major problem and a cooling system is not required.

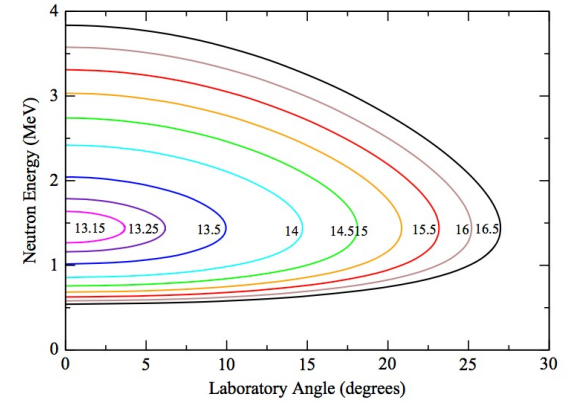

**Fig. 1.** Kinematic curves relating the angle of neutron emission to neutron energy in the laboratory frame for different  $^7\text{Li}$  bombarding energies from 13.15 to 16.5 MeV, calculated using two-body relativistic kinematics.

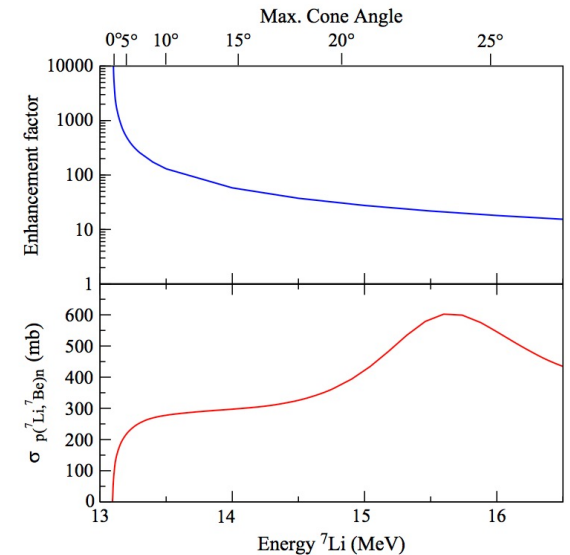
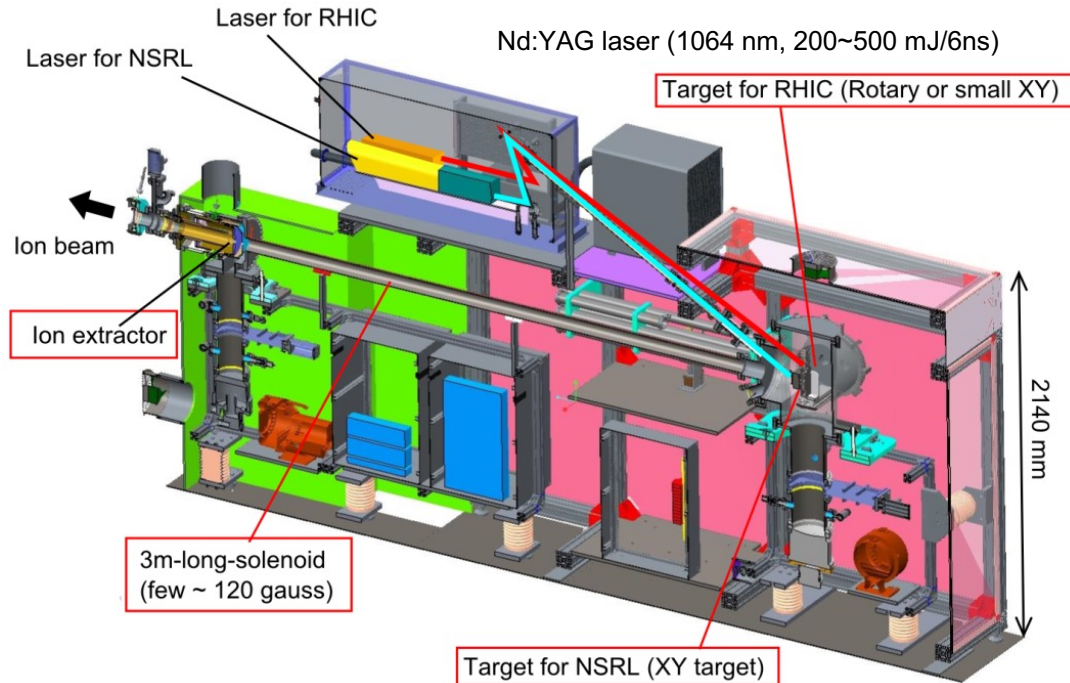

**Fig. 2.** The top panel shows the enhancement factor of the neutron flux between the inverse kinematic and the direct kinematic reaction as a function of  $^7\text{Li}$  bombarding energy. The bottom panel shows the  $p(^7\text{Li},^7\text{Be})n$  reaction cross-section over the same energy range.



BNL has a long experience for providing stable beams from a laser ion source.

## Laser Ion Source development at BNL



- The first beam in 2014 (since then no major maintenances on beam extractors)
- Pressure <math> < 10^{-4}</math> Pa
- Species switching within a few second, more than 20 species.
- No coupling between beam for RHIC and NSRL

## Advantages of laser ion source (LIS)

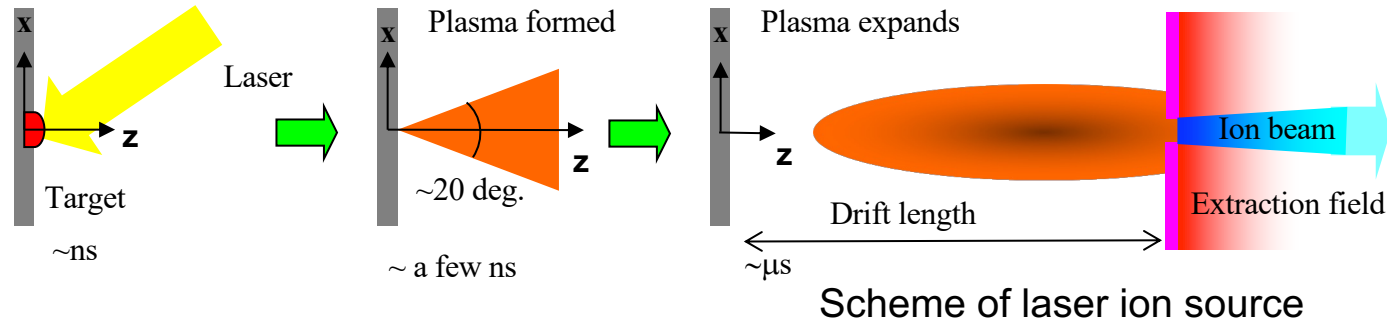

- High density plasma created from a solid.
- Fast switching target materials.
- Low temperature after adiabatic expansion.
- Uniform density of beams.

# Solenoid plasma guide plus DPIS

APPLIED PHYSICS LETTERS **105**, 193506 (2014)



## Laser ion source with solenoid field

Takeshi Kanesue,<sup>1,a)</sup> Yasuhiro Fuwa,<sup>2,3</sup> Kotaro Kondo,<sup>4</sup> and Masahiro Okamura<sup>1</sup>

<sup>1</sup>Collider-Accelerator Department, Brookhaven National Laboratory, Upton, New York 11973, USA

<sup>2</sup>Graduate School of Science, Kyoto University, Kitashirakawa, Sakyo, Kyoto 606-7501, Japan

<sup>3</sup>RIKEN, 2-1 Hirosawa, Wako, Saitama 351-0198, Japan

<sup>4</sup>Research Laboratory for Nuclear Reactors, Tokyo Institute of Technology, 2-12-1 Ookayama, Meguro, Tokyo 152-8550, Japan

(Received 27 August 2014; accepted 27 October 2014; published online 12 November 2014)

Pulse length extension of highly charged ion beam generated from a laser ion source is experimentally demonstrated. The laser ion source (LIS) has been recognized as one of the most powerful heavy ion source. However, it was difficult to provide long pulse beams. By applying a solenoid field (90 mT, 1 m) at plasma drifting section, a pulse length of carbon ion beam reached  $3.2 \mu\text{s}$  which was 4.4 times longer than the width from a conventional LIS. The particle number of carbon ions accelerated by a radio frequency quadrupole linear accelerator was  $1.2 \times 10^{11}$ , which was provided by a single 1 J Nd-YAG laser shot. A laser ion source with solenoid field could be used in a next generation heavy ion accelerator. © 2014 AIP Publishing LLC. [<http://dx.doi.org/10.1063/1.4902021>]

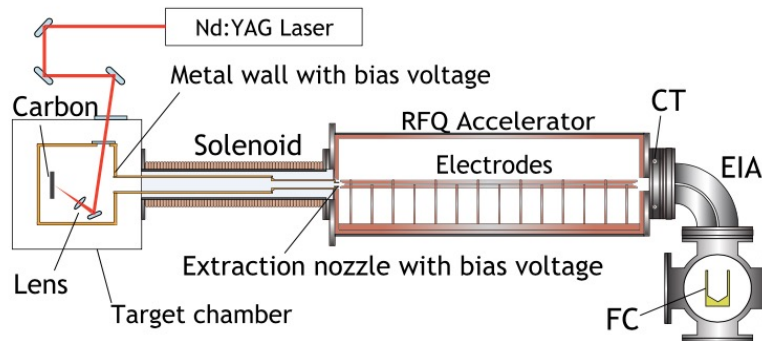

FIG. 3. Setup for ion acceleration by RFQ.

We have demonstrated that  $1.2 \times 10^{11}$  of  $\text{C}^{4+}$  can be provided by a single laser shot.

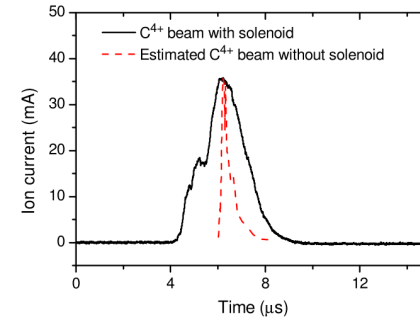

FIG. 5.  $\text{C}^{4+}$  beam with and without solenoid under the same laser irradiation condition. The wave form without solenoid is estimated based on the plasma measurement.

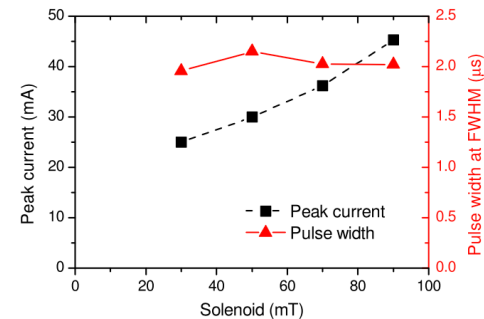

FIG. 6. CT peak current and pulse width at FWHM as a function of solenoid field.

## New electrodes were designed

To demonstrate acceleration of high current lithium beam, we developed RFQ electrodes. It was predicted that the RFQ accelerates 40 mA of  ${}^7\text{Li}^{3+}$  beam.

Basic parameters of RFQ

Parameter	Value
Structure	4 Rod
Frequency	100 MHz
Input energy	22 keV/n
Output energy	204 keV/n
Input beam current	50 mA
Transmission	80%
RFQ length	1977 mm

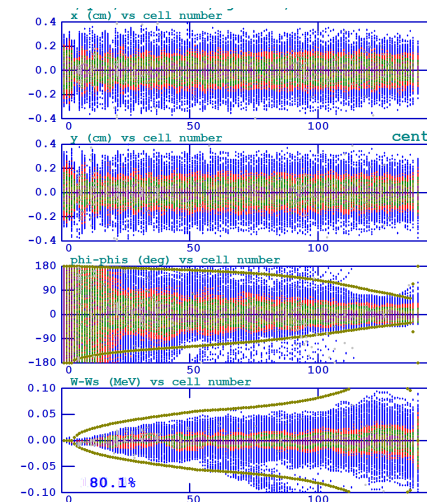

## RFQ ready for Li beam

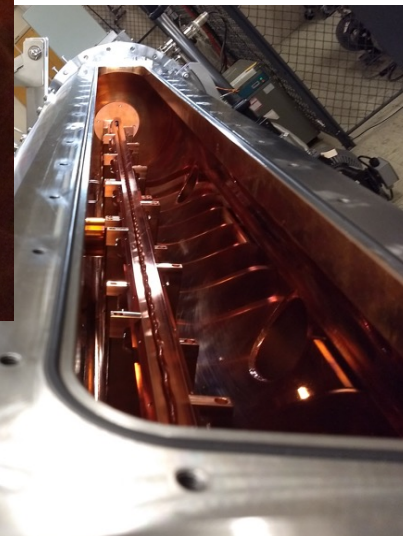
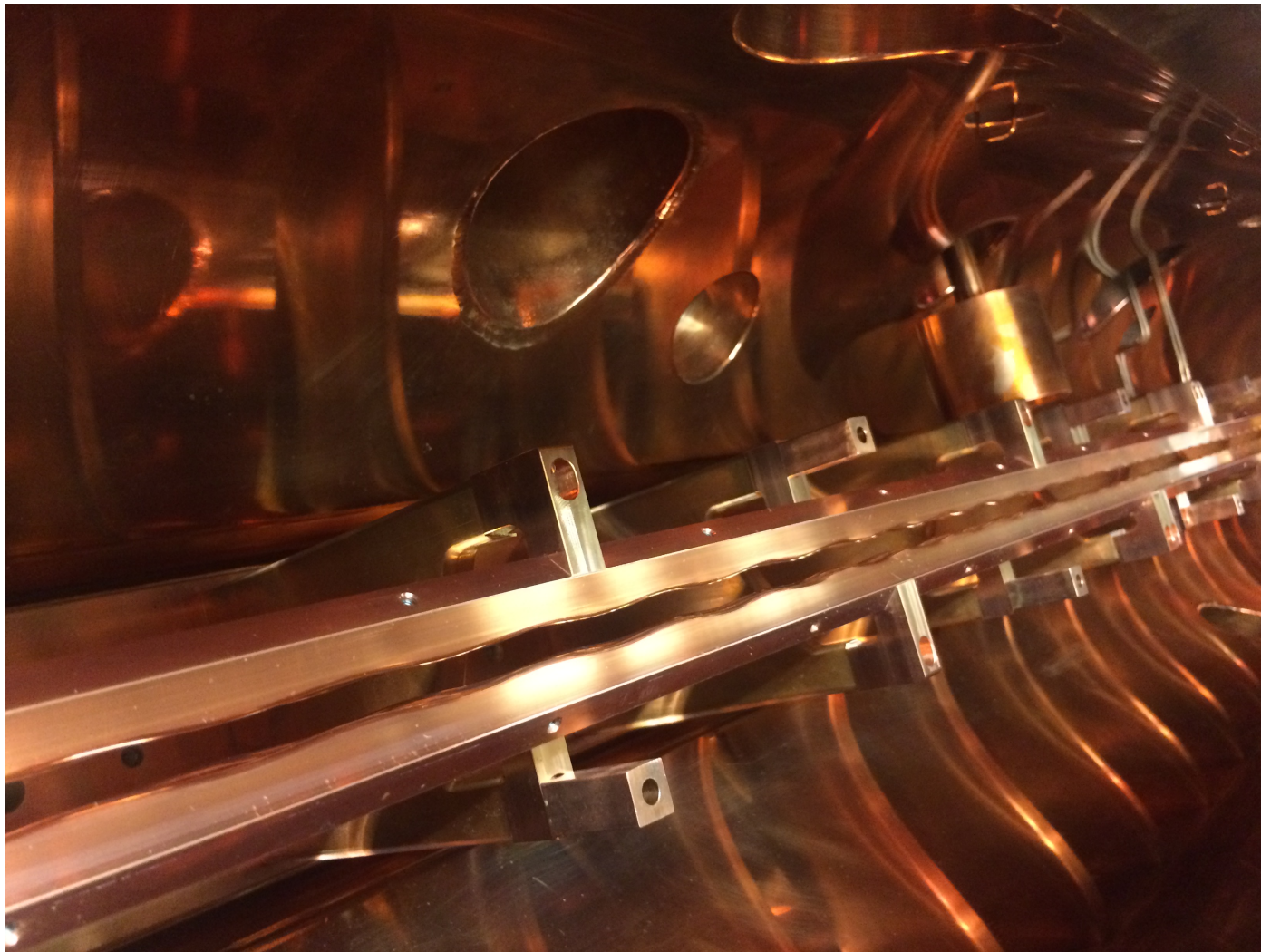

## Analyzing beam line with the RFQ

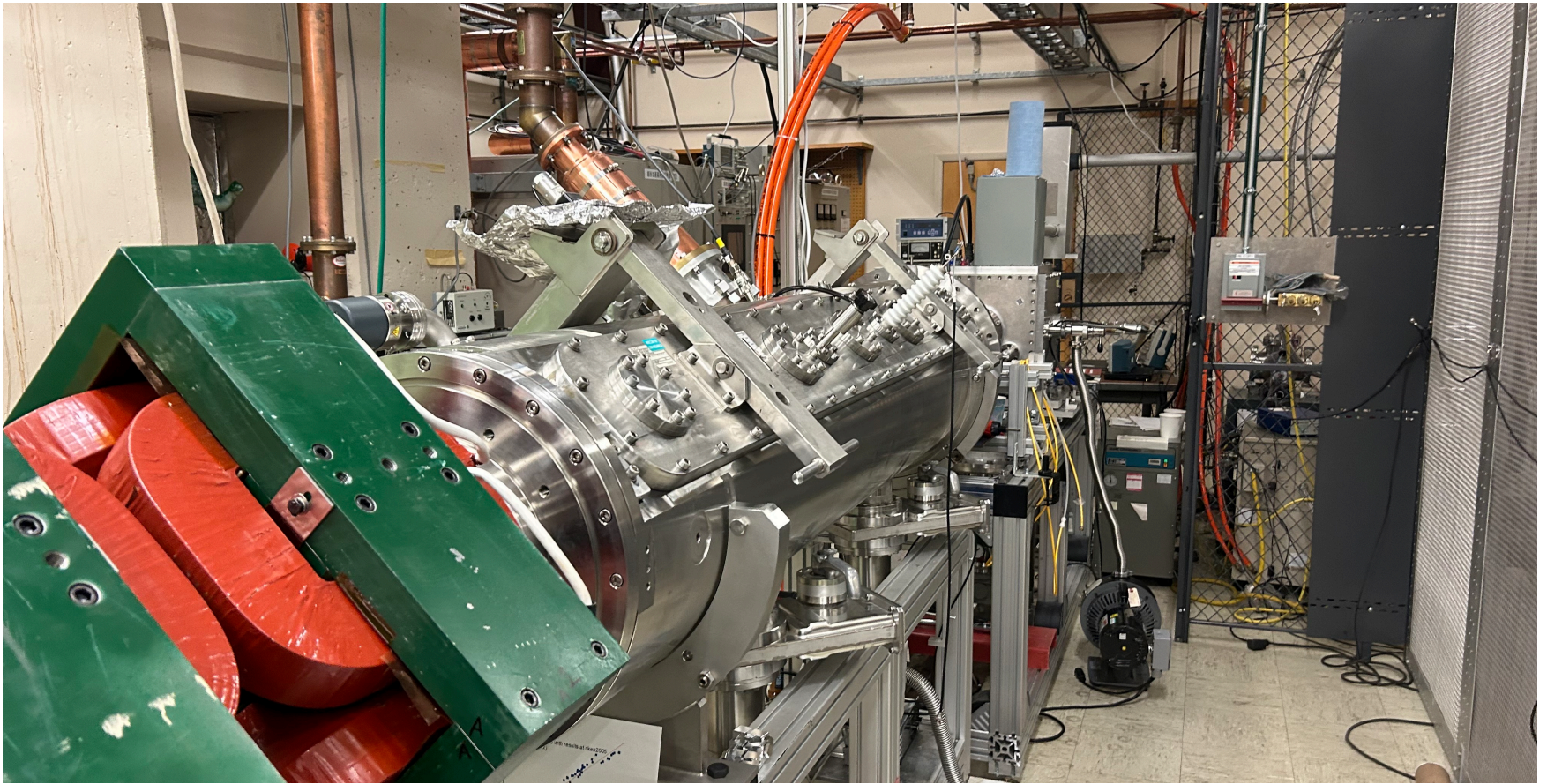

## Li target fabrication

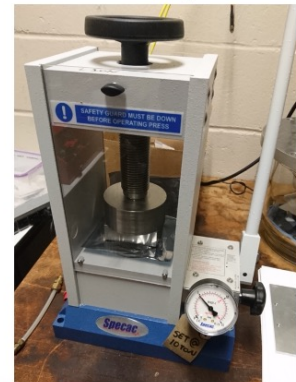

- Glove bag filled with Ar was used.
- Li was cut and contained in pouch without exposure to air.

Li in pouch was pressed to have flat surface

## Li target installation

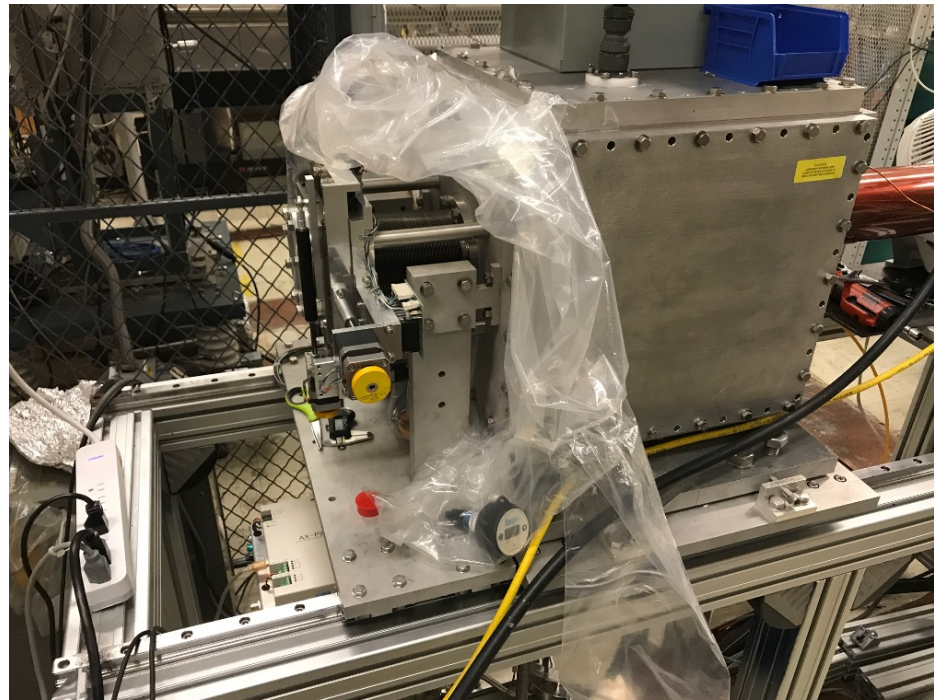

- Plastic bag with manipulation gloves was attached between flange and chamber.
- Li was taken out from pouch and mounted on target stage in plastic bag.
- Flange was closed and pumping started without breaking seal.
- Li was not exposed to air at all during this process.



# Lithium target exposed to the air

6 min



30 min





Contamination of target due to chemical reaction in air

LiOH and Li<sub>3</sub>N are formed on target

- $\text{Li} + \text{H}_2\text{O} \rightarrow \text{LiOH} + 1/2\text{H}_2$
- ${}^6\text{Li} + \text{N}_2 \rightarrow 2\text{Li}_3\text{N}$
- $\text{Li}_3\text{N} + 3\text{H}_2\text{O} \rightarrow \text{NH}_3 + 3\text{LiOH}$

Q/A of  ${}^7\text{Li}^{3+}$ ,  $\text{O}^{7+}$ , and  $\text{N}^{6+}$  are close

$\text{O}^{7+}$ , and  $\text{N}^{6+}$  may be contained in accelerated beam

# Acceleration test setup

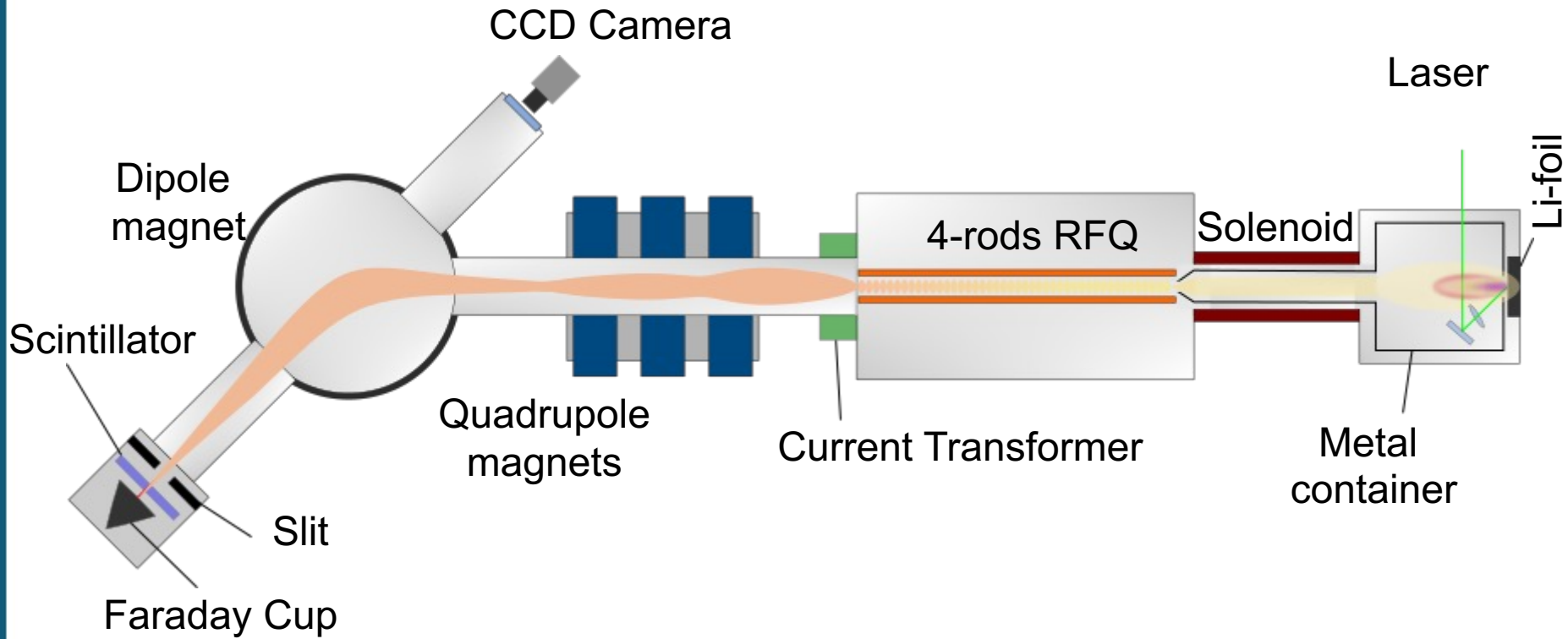

# Accelerated $7\text{Li}^{3+}$ beam (parameters from target to FC were optimized for $7\text{Li}^{3+}$ )

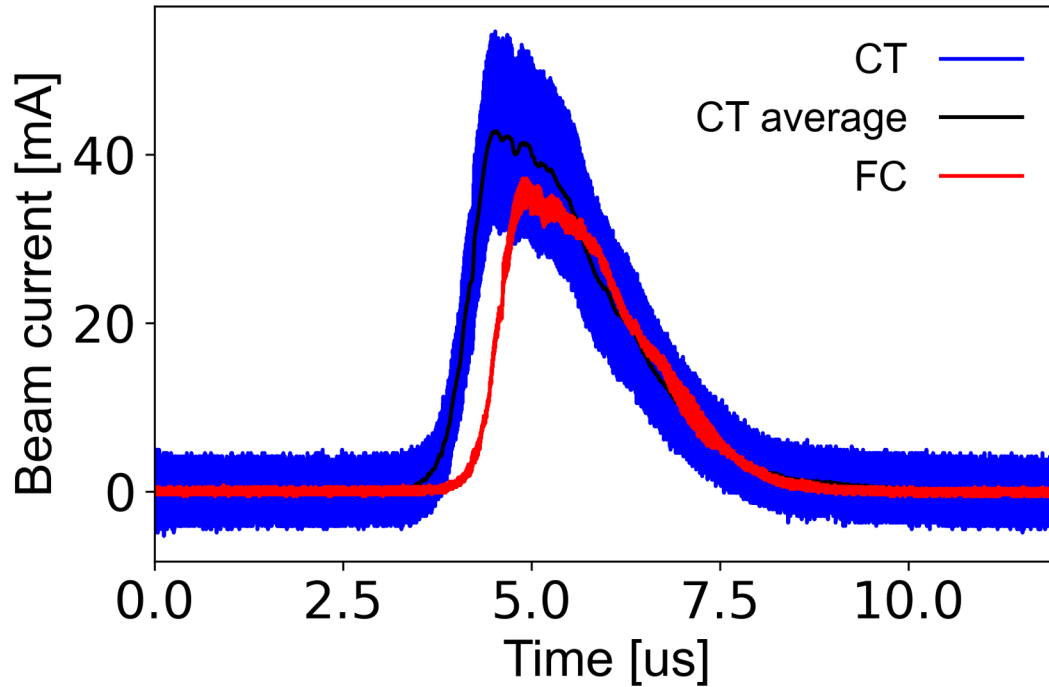

- Laser
  - Thales
  - QS220 us,
  - 1.6 J at laser exit (~0.8 J at target)
- Solenoid : 15 A (790 G)
- Extraction voltage : 52 kV
- RF power : ~ 100 kW
- Q1 : 8A
- Q2 : 13.2 A
- Q3 : 6.8 A
- Dipole : 110 A (2.7 kG)
- Ring bias : -400 V

CT peak : 43 mA, 95 nC  
FC peak : 35 mA, 74 nC  
FWHM : 2.0 us

# Analyzed beam

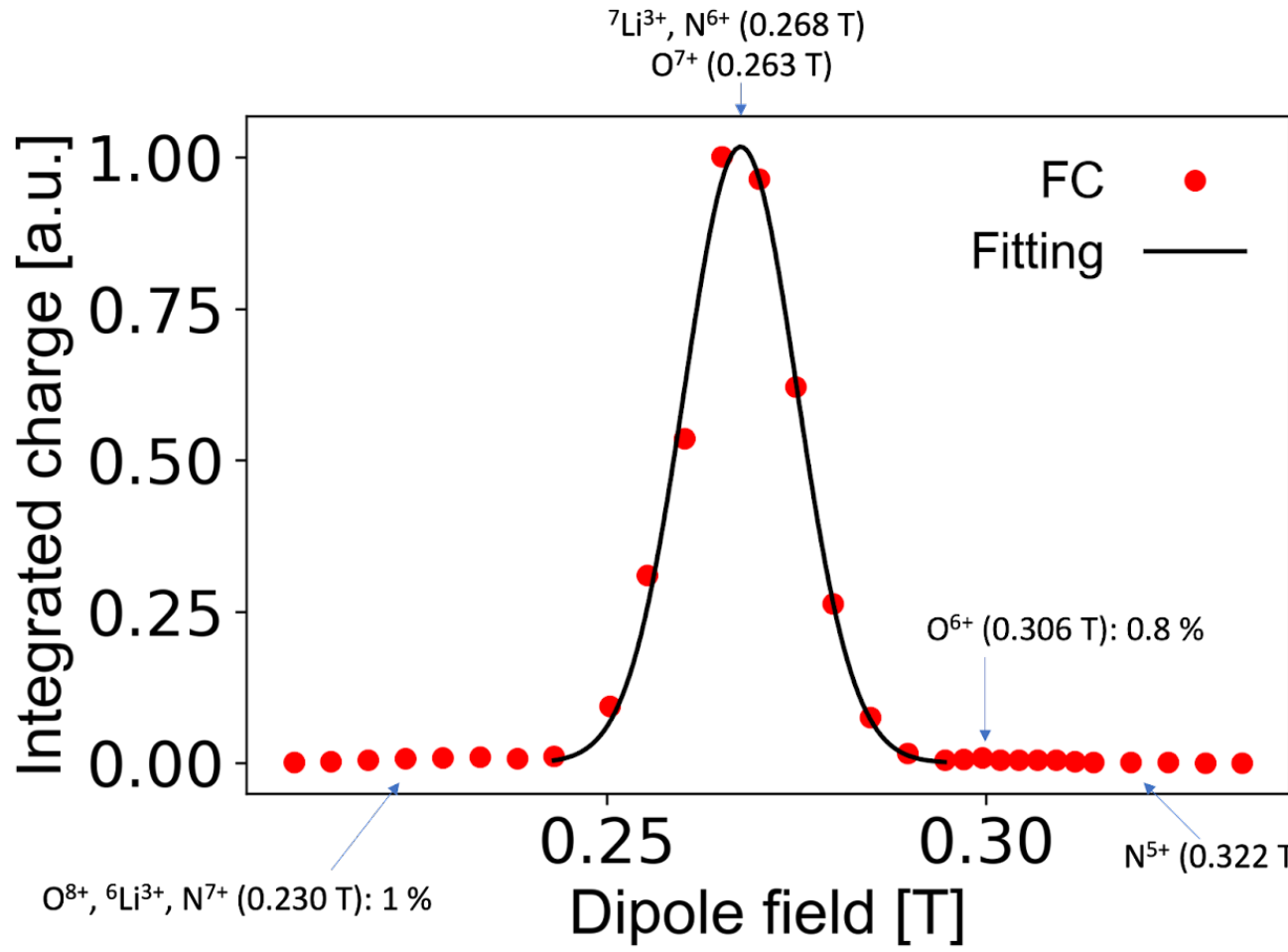

Ion	Q/A
$\text{O}^{8+}$	0.500
${}^6\text{Li}^{3+}$	0.500
$\text{N}^{7+}$	0.500
$\text{O}^{7+}$	0.438
${}^7\text{Li}^{3+}$	0.429
$\text{N}^{6+}$	0.429
$\text{O}^{6+}$	0.375
$\text{N}^{5+}$	0.357
${}^6\text{Li}^{2+}$	0.333
$\text{O}^{5+}$	0.313
${}^7\text{Li}^{2+}$	0.286
$\text{N}^{4+}$	0.286

➡ Contamination ~ 2 %

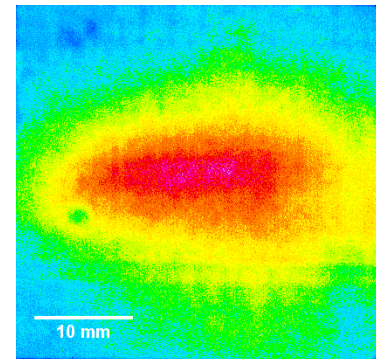

# 14 MeV lithium driver neutron generator

Next step

- Design of high current IH linac
- Neutron simulation based of realistic beam parameters
- Design of neutron generation chamber
- Estimate required shielding

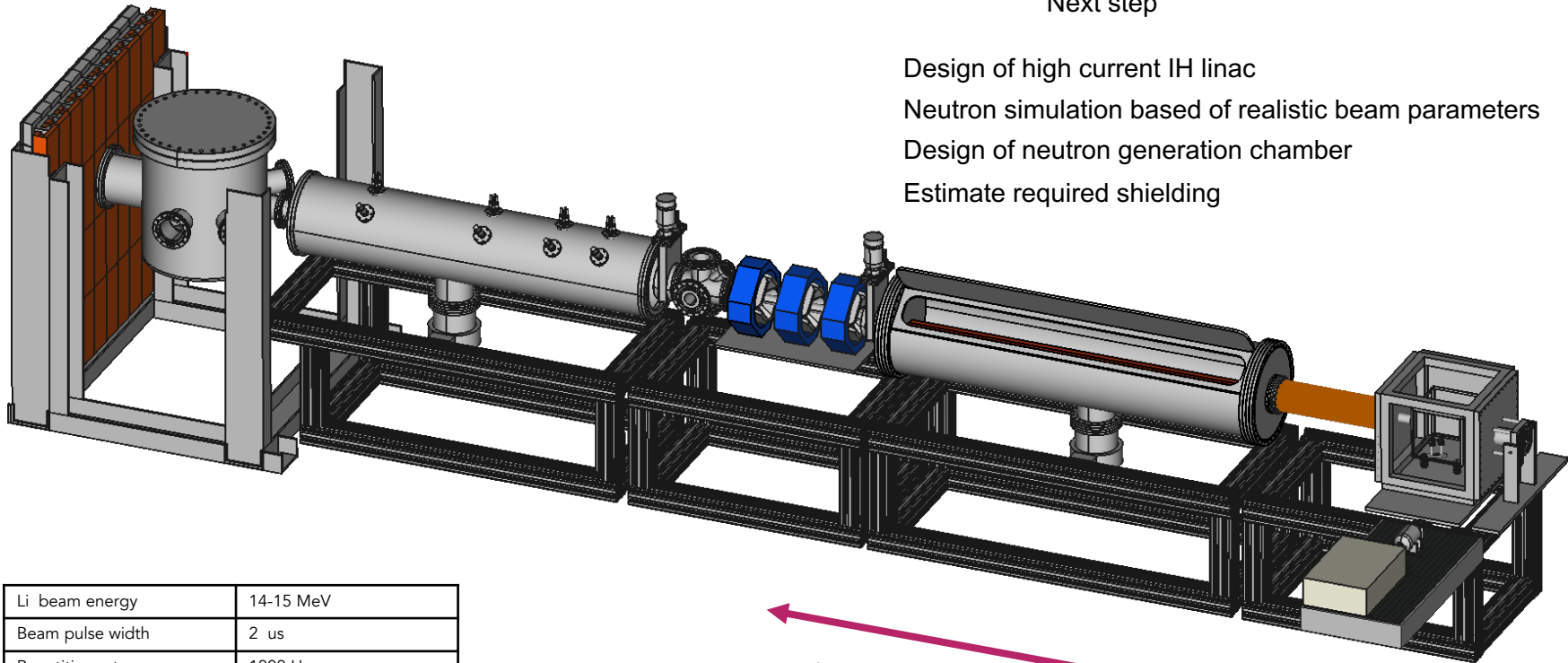

*This part was completed*

Li beam energy	14-15 MeV
Beam pulse width	2 $\mu$ s
Repetition rate	1000 Hz
Peak ion beam current	35 mA
Average ion beam current	70 $\mu$ A
Neutron energy	1 MeV - 5 MeV
Average neutron flux	$7 \times 10^9$ n/s/sr

# Recent study 1: New controlled plasma extraction nozzle

Taper nozzle electrode

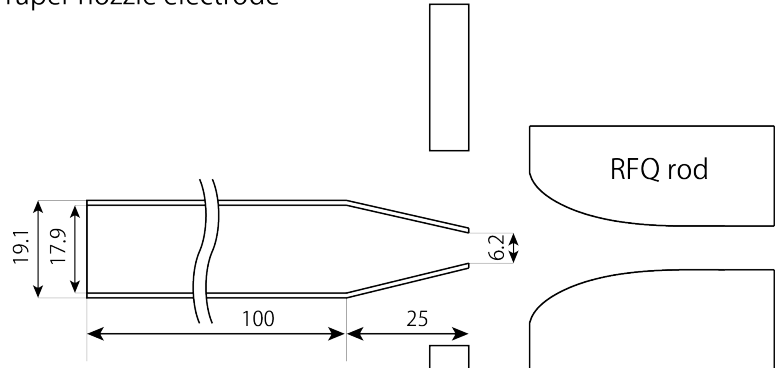

ID 6.2 mm  
Extraction Area 30.18 mm<sup>2</sup>

Concave surface nozzle electrode

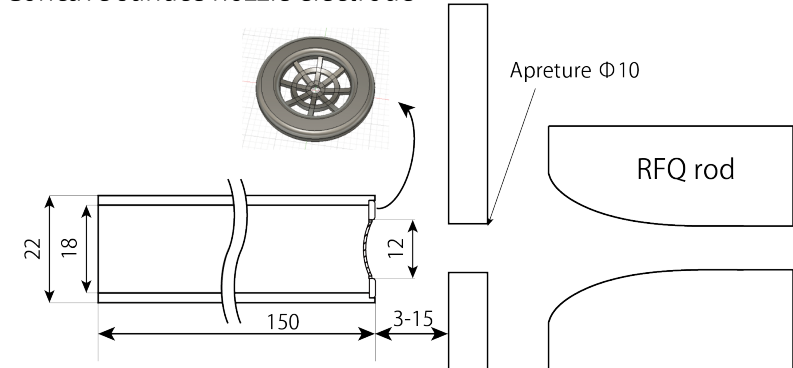

ID 12 mm  
Extraction Area 64.77 mm<sup>2</sup>





# Recent study 2: New Radial Matching Section of RFQ

Trying to simulate beam capture

- In DPIS, DC extraction voltage is applied between nozzle and RFQ rods.
- This is not considered in parmteq simulation.
- Shapes of nozzle and rods were optimized to maximize ion capture with IGUN and OPERA3D+GP

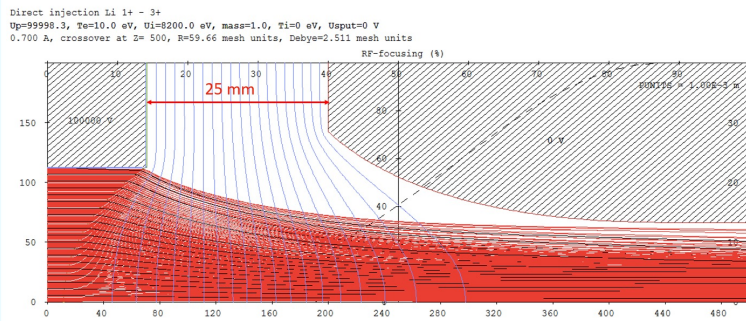

Iteration

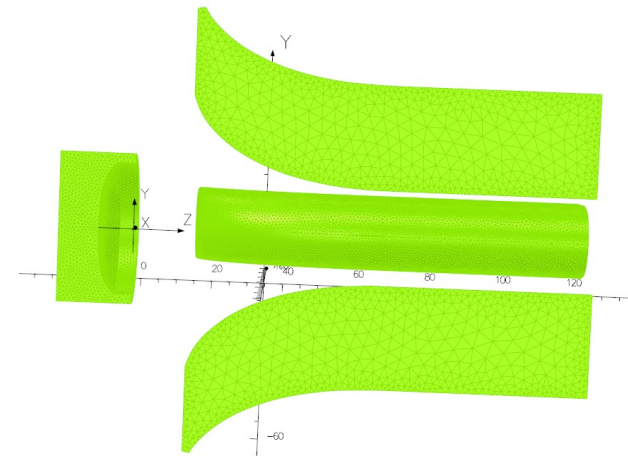

- IGUN simulation for plasma boundary calculation
- Axisymmetric + no RF
- Parameter = Aperture and gap distance

- OPERA3D and GPT simulation for ion capture
- No plasma boundary calculation  
(defined emitting surface)
- Parameter: Rod diverging shape

L = 25 mm, dt = 100 ns, I<sub>peak</sub> = 1 A - 1.3 A, 4.2 keV initial kinetic energy

Simulation condition

OPERA Formula  
t = 6.67e-09

GPT + OPERA/Formula  
10 RF periods

x [mm]

- red 6Li1
- green 6Li2
- blue 6Li3
- magenta 7Li1
- cyan 7Li2
- black 7Li3

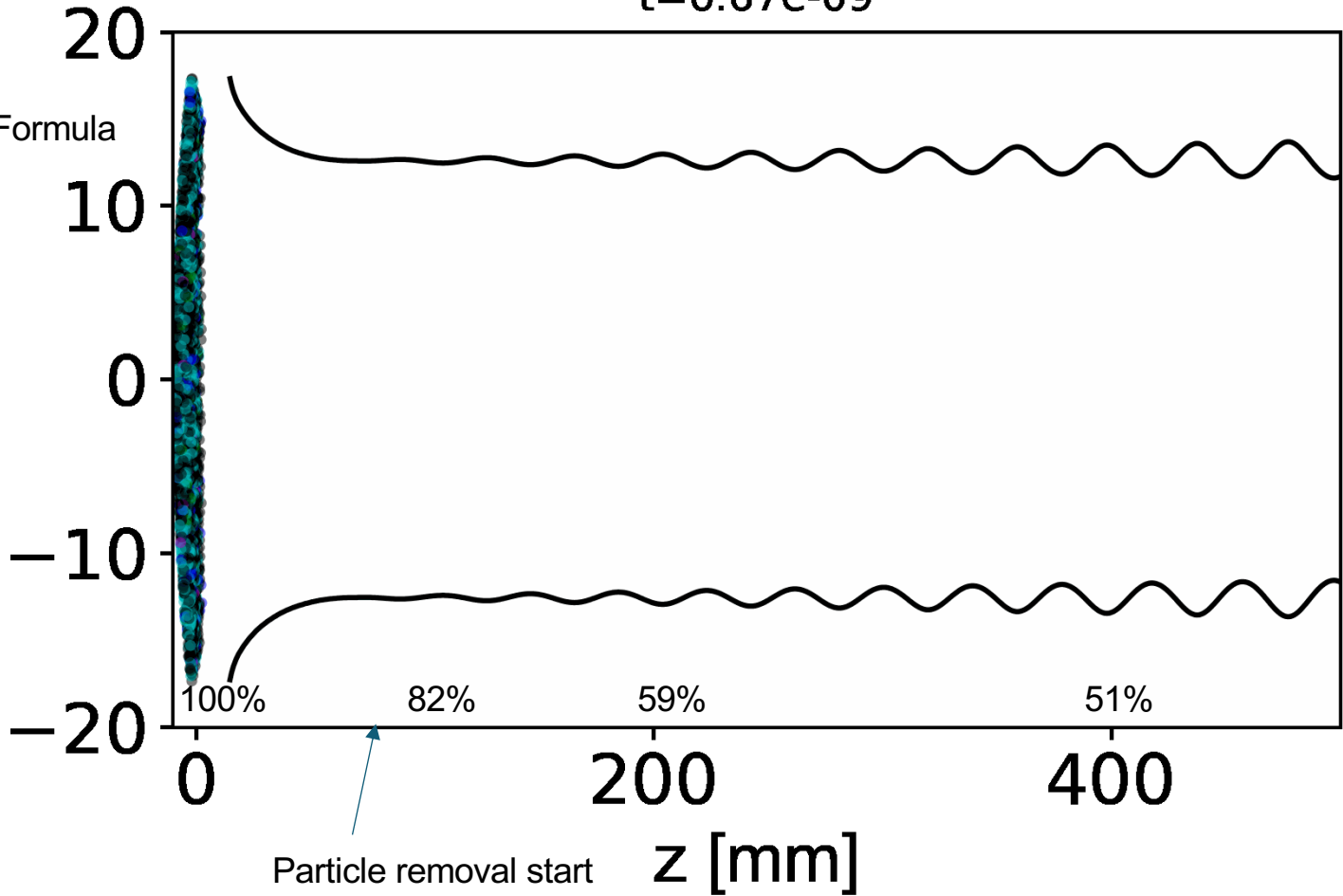

Output current

- 7Li3 : 350 mA
- Others : almost no ions accelerated

# Recent study 3: Liquid lithium target for laser ion source

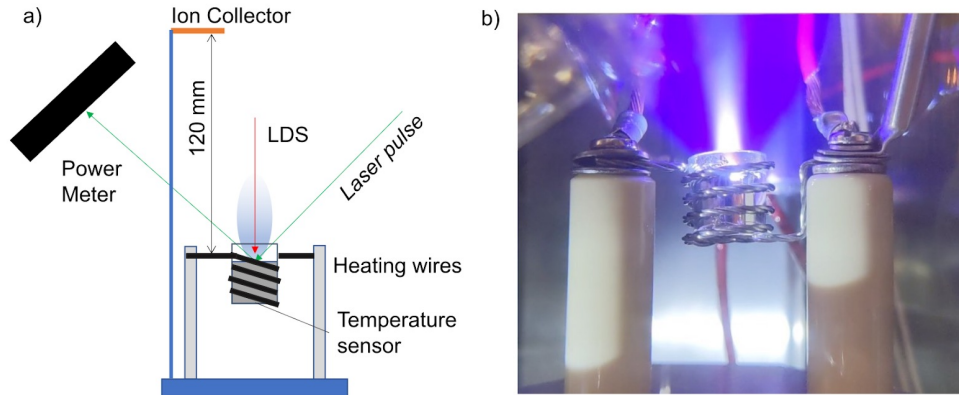

- Liquid Ga was tested
- Vapor deposition of Lithium was tested
- Vertical plasma diagnosis beam line is being fabricated

Test with melted Ga.

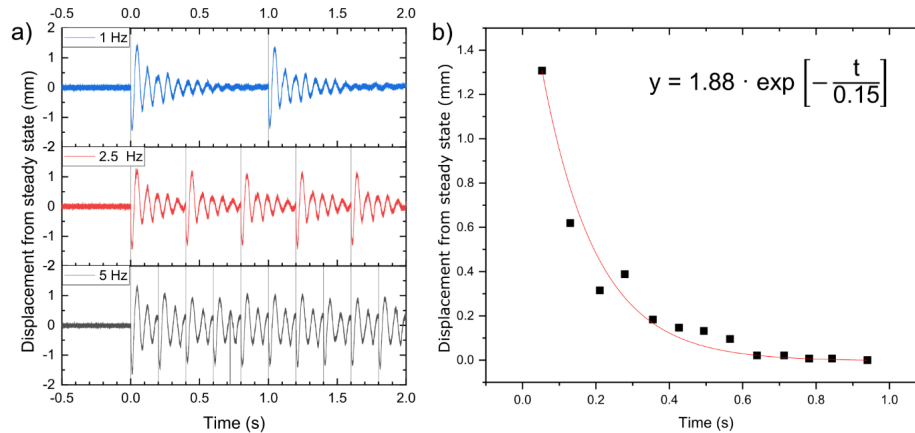

Wave induced by a laser shot on melted Ga surface

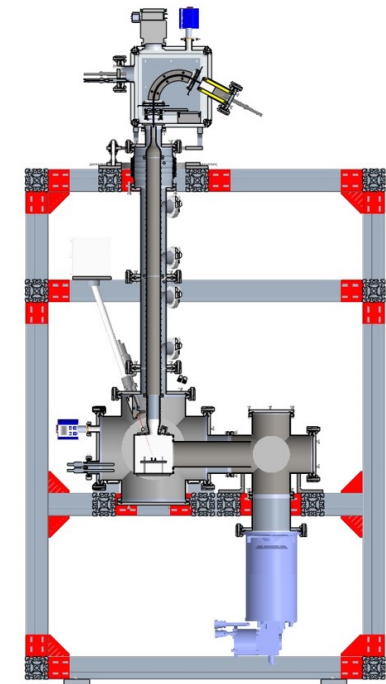

Vertical test line

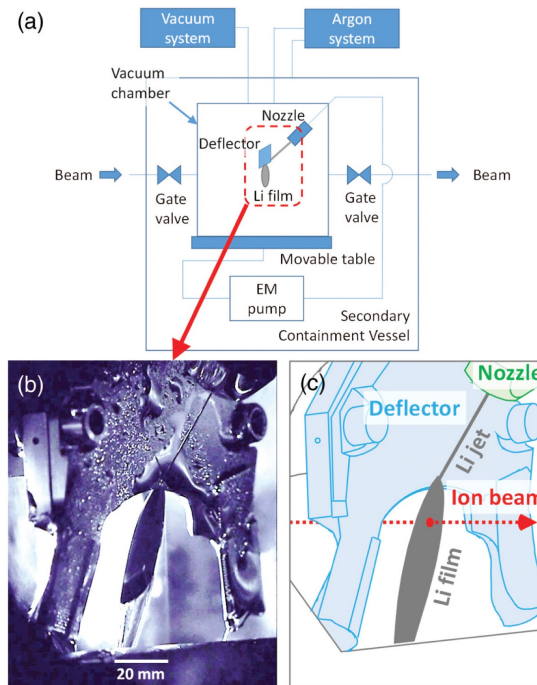

FIG. 1. Schematic of liquid lithium charge stripper system and lithium film. (a) Schematic illustration of the LLCSS system, area indicated by red-dot line with more details shown in (b) and (c). (b) Photograph of the liquid lithium film formed in the LLCSS vacuum chamber. The extremely smooth surface of the lithium film appeared as a mirror. (c) Illustration of the liquid lithium film with labels for clarity.

PHYSICAL REVIEW LETTERS 128, 212301 (2022)

## FRIB established lithium curtain system

This device could be used as a laser target as it is.

## Summary

Neutron generator based on intense lithium beam driver was proposed as a clean compact source.

RFQ linac was designed and tested with  $\text{Li}^{3+}$  ions.

- 35 mA (peak) beam was accelerated
- Almost no contamination

**Feasibility of lithium driven neutron generator was verified.**

A higher beam current is achievable by studying plasma injection region.

Design work of an IH-linac and Neutron generation target are started.

Collaboration for BNCT with ANSTO, Wollongong University, Tokyo Medical Dental University and Columbia University.

FRIB type lithium curtain could be used as a lithium laser target.

**Thank you for your  
attention**