



science  
week / 23  
JUL 31 - AUG 4



SCIPP  
SANTA CRUZ INSTITUTE  
FOR PARTICLE PHYSICS  
UC SANTA CRUZ

# LGADs for particle, nuclear physics and beyond

Dr. Simone M. Mazza (SCIPP, UC Santa Cruz)  
**TRIUMF science week 2023**



# Talk overview

- I. LGAD technology, timing and 4D tracking
- II. Radiation resistant LGAD design
- III. High granularity LGADs
- IV. LGAD applications in HEP and NP
- V. X-ray detection with LGADs
- VI. Gain suppression effects

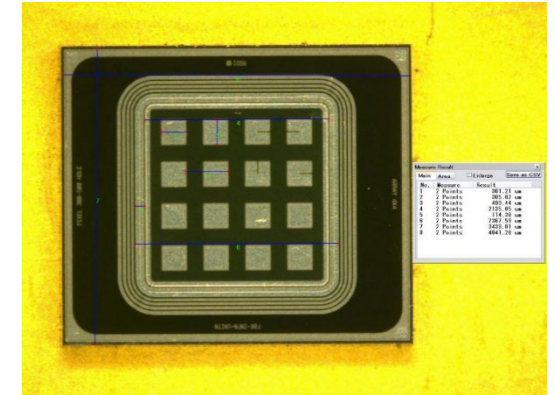
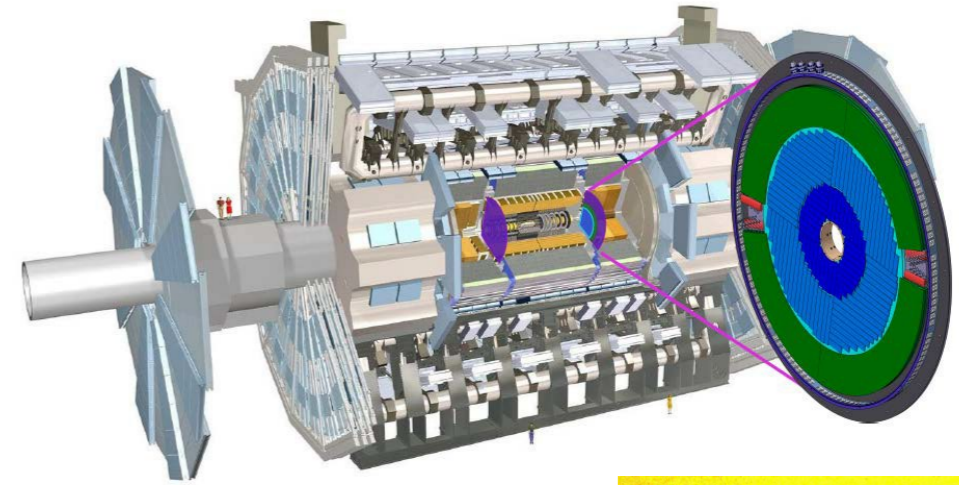

# I. LGAD technology

---

Time resolution challenge

# Low Gain Avalanche Detectors

- LGAD: silicon detector with a thin ( $<5 \mu\text{m}$ ) and highly doped ( $\sim 10^{16} \text{ P}^{++}$ ) multiplication layer
  - High electric field in the multiplication layer
  - Field is high enough for electron multiplication but not hole multiplication
- LGADs have intrinsic modest internal gain (10-50)
  - $\text{Gain} = \frac{Q_{\text{LGAD}}}{Q_{\text{PiN}}}$  (collected charge of LGAD vs same size PiN)
  - Not in avalanche mode  $\rightarrow$  controlled tunable gain with applied bias voltage
- **Great hit time resolution:  $<20 \text{ ps!}$**
- Several producers of experimental LGADs
  - CNM (Spain), HPK (Japan), FBK (Italy), BNL (USA), NDL (China)

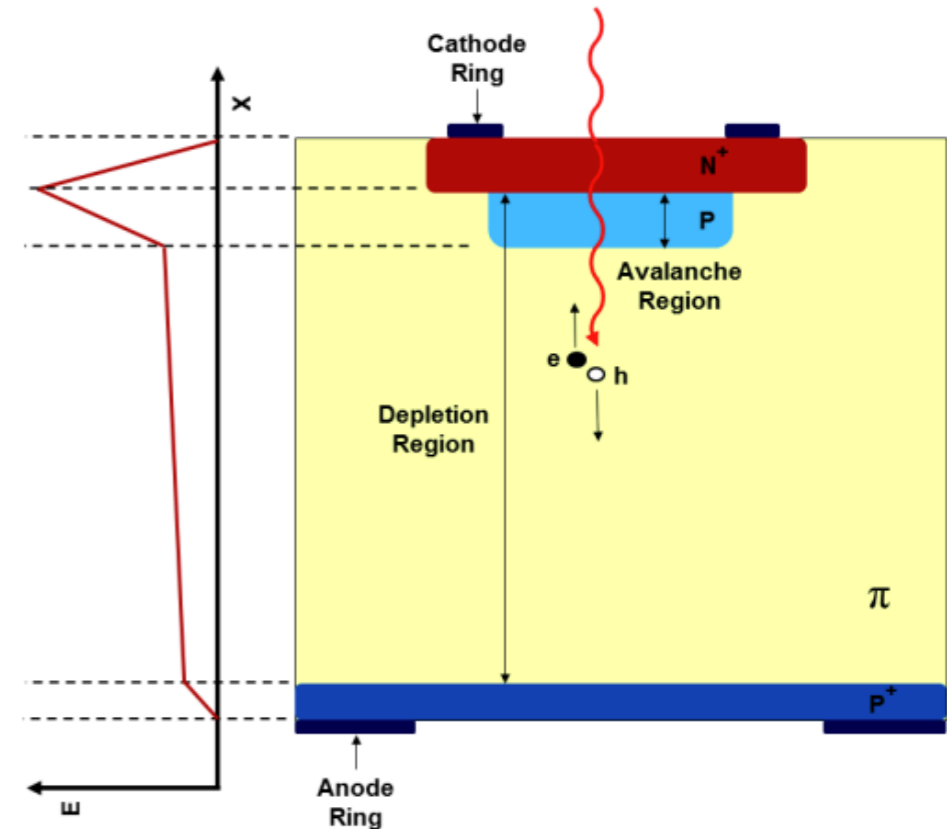

[Nucl. Instrum. Meth. A765 \(2014\) 12–16.](#)

[Nucl. Instrum. Meth. A831 \(2016\) 18–23.](#)

# Time resolution

## Sensor time resolution main terms

$$\sigma_{\text{timing}}^2 = \sigma_{\text{time walk}}^2 + \sigma_{\text{Landau noise}}^2 + \sigma_{\text{Jitter}}^2 + \sigma_{\text{TDC}}^2$$

- **Time walk:**

- Minimized by correcting the time of arrival using pulse width or pulse height (e.g., use 50% of the pulse as ToF)

- **Jitter:** from electronics

- Proportional to  $1/\frac{dV}{dt}$
- Reduced by increasing S/N ratio with gain

- **TDC term:** from digitization clock (electronics)

- **Landau term:** proportional to silicon sensor thickness

- Reduced for thinner sensors
- Dominant term at high gain

- **Bottom line: thin detectors with high S/N**

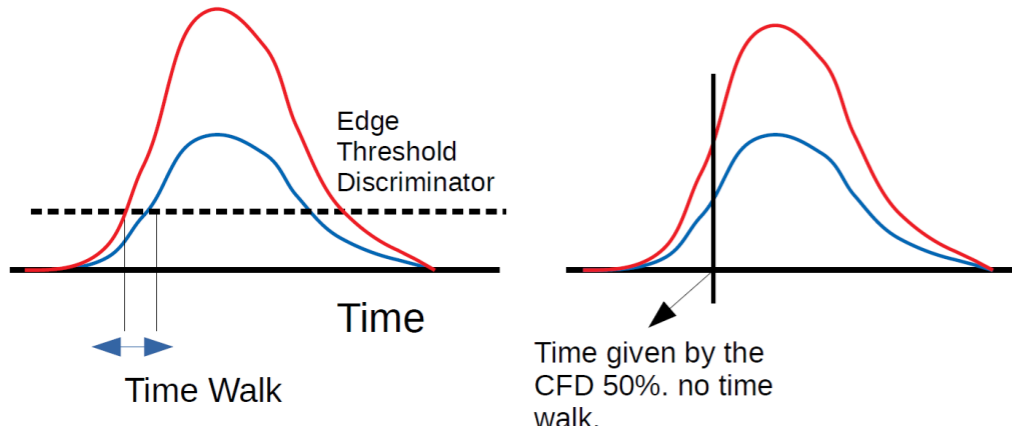

Landau variations

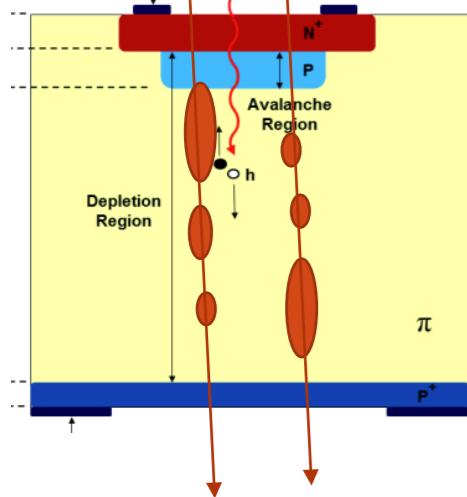

Noise on top of the signal.

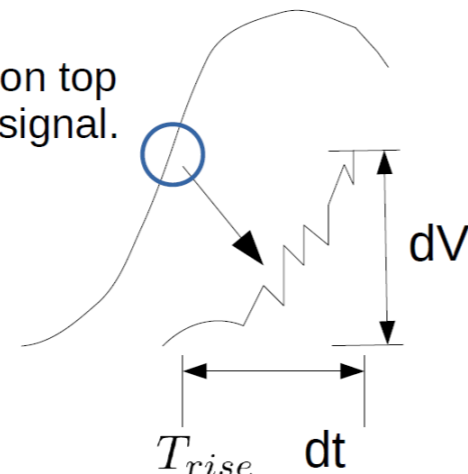

$$\sigma_{\text{Jitter}} = \frac{\text{Noise}}{dV/dt[\text{CFD}\%]} \approx \frac{T_{\text{rise}}}{\text{SNR}} dt$$

# Silicon detector

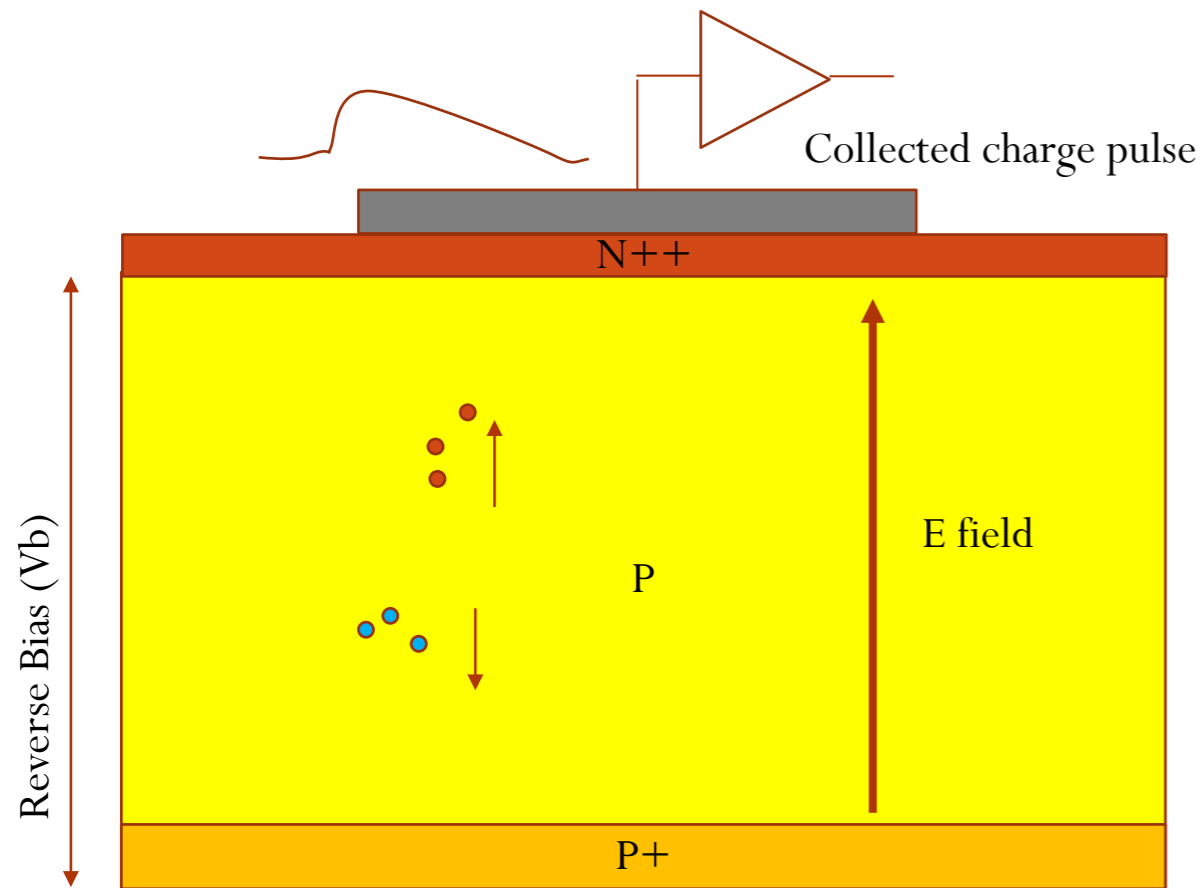

# LGAD

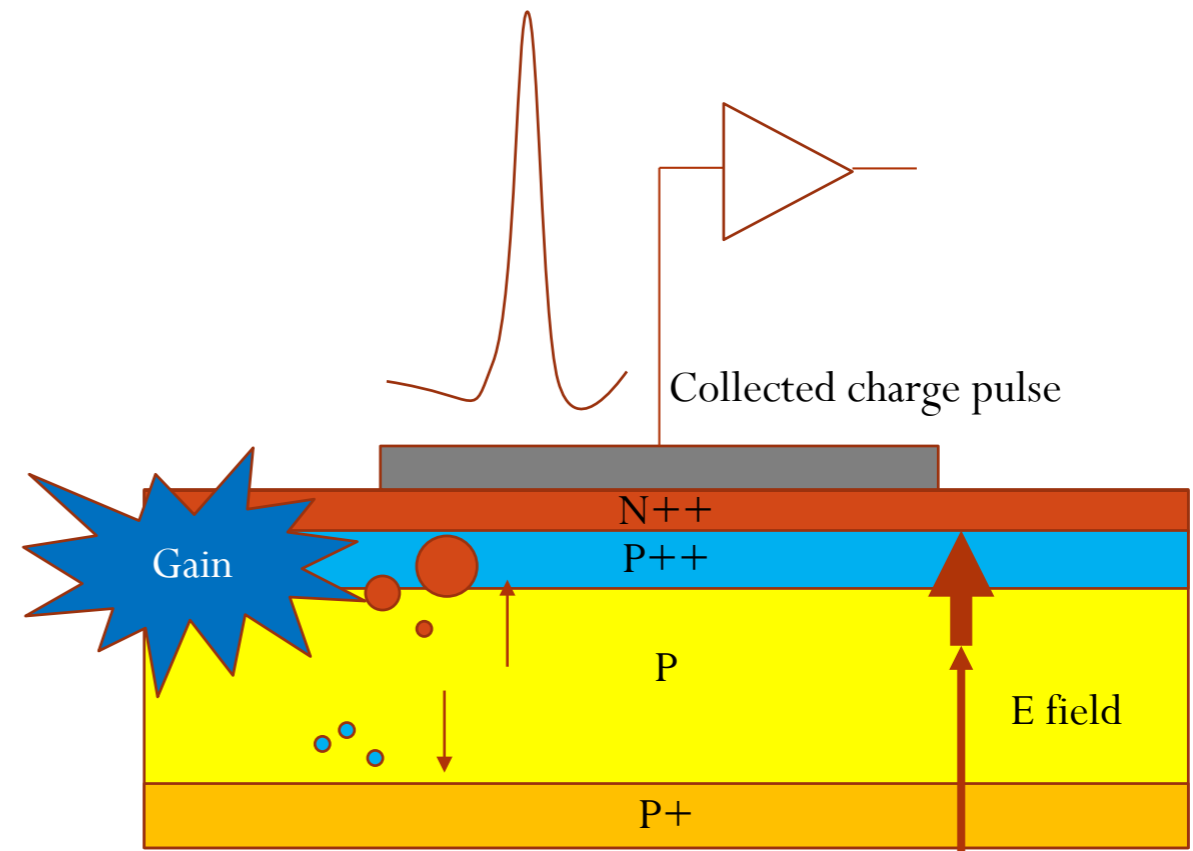

- Collected charge from a MiP is proportional to sensor thickness: a standard silicon detector needs to be a few 100s um thick to get a decent S/N
- **Thanks to gain LGADs can be thinner, with a shorter pulse with better S/N**

# Time resolution vs thickness

- When sensor has high gain there's **very low jitter contribution** to the time resolution, ultimately driven by Landau component → **Depends on sensor thickness**

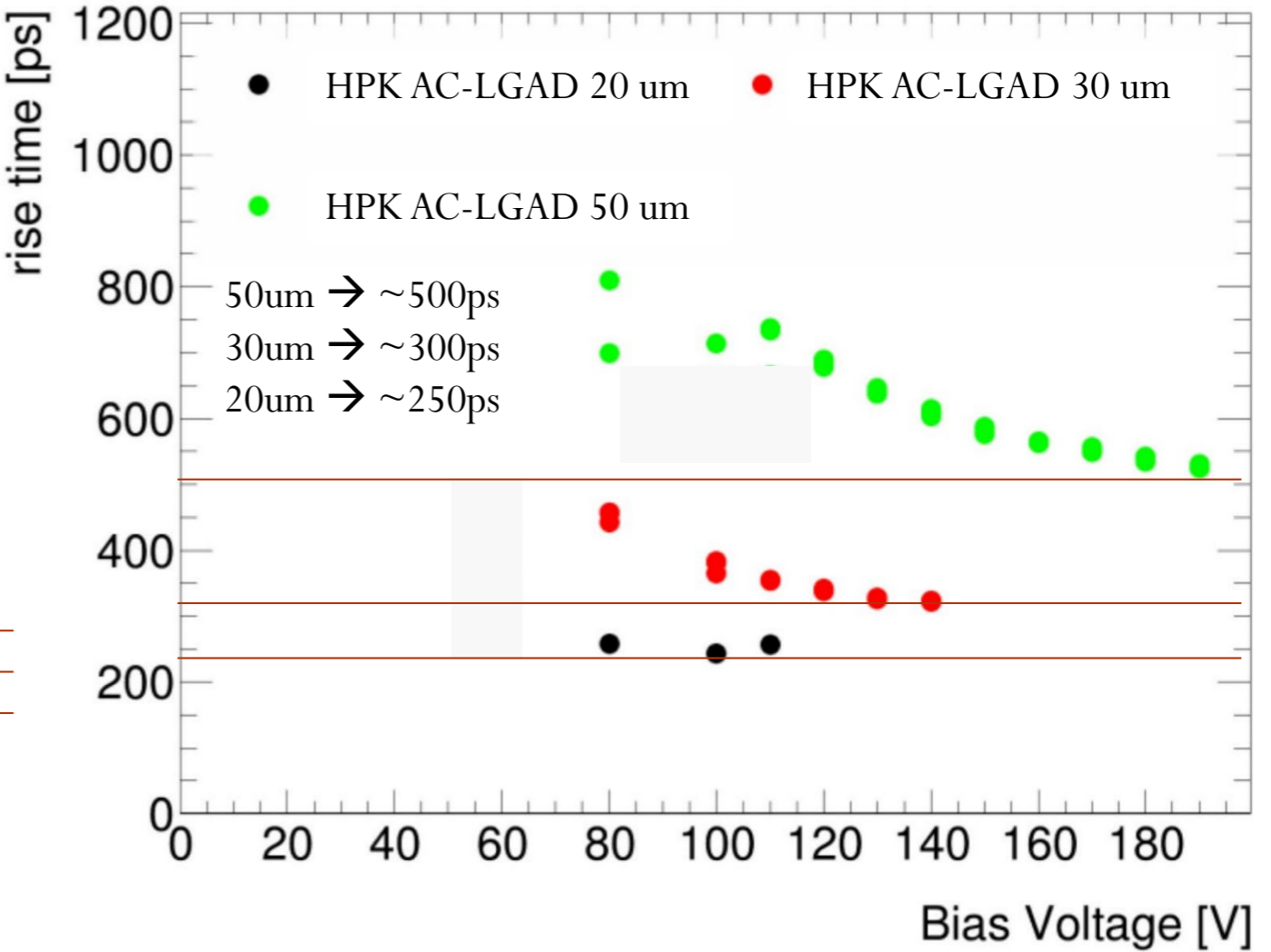
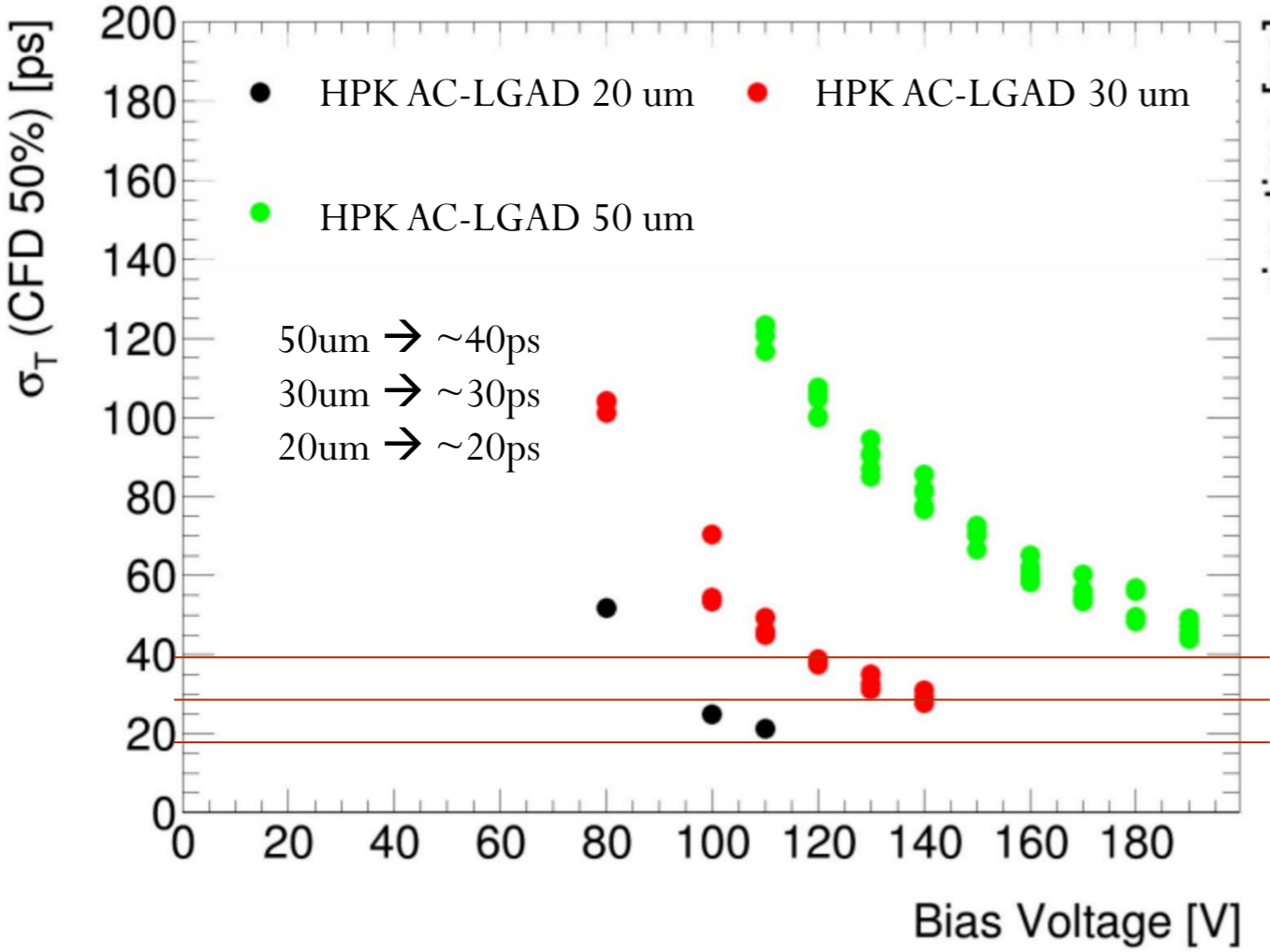

# 4D tracking - concept

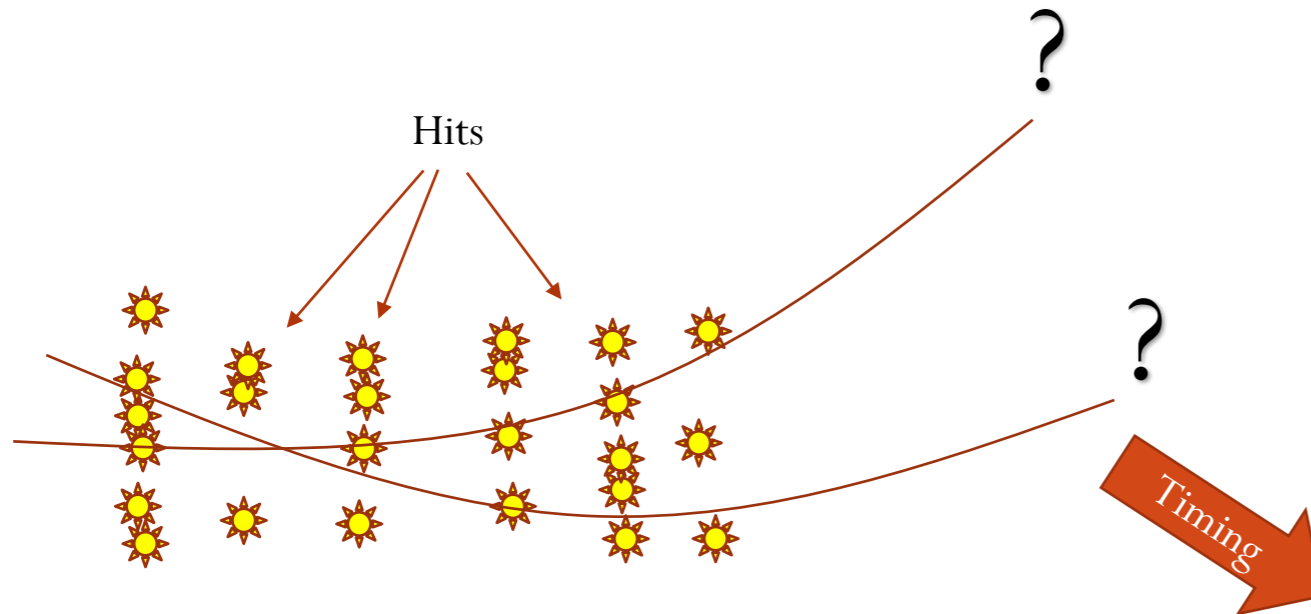

- Collection of hits for multiple tracks in dense environment
  - Harder to reconstruct tracks with usual algorithms
- But if particles have different initial position (vertex) or delayed in time (from pileup)
  - We can exploit the **time** of the single hits
- Easier to reconstruct single tracks
- $\sim\text{ps} \rightarrow \sim\text{mm}$  at speed of light,  $1 \rightarrow 100\text{ps}$  is the needed time resolution for usual collider beam spot size

- Efficient tracking in dense environment
  - Pile-up suppression
  - Long Lived Particle detection
  - Appearing/Disappearing tracks identification
  - ToF-based particle identification
  - Jet flavor tagging enhancement

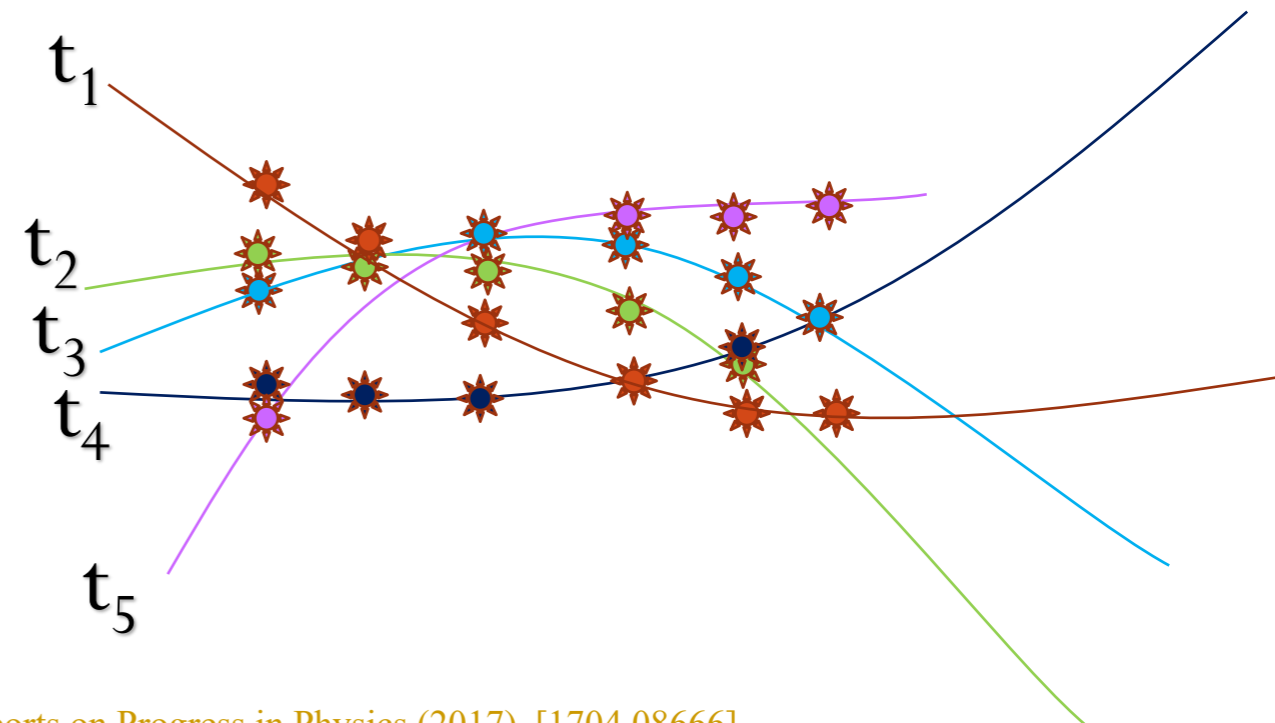



## II. Radiation resistant LGAD design

---

Radiation hardness challenge

# LGAD and radiation damage

- LGADs while operating in high energy physics experiments will sustain radiation damage
  - Both in terms of fluence and ionization dose
- Change in performance caused by reduced doping concentration in the gain layer by **acceptor removal mechanism**
  - Some details: <https://doi.org/10.1016/j.nima.2018.11.121>

Performance effects of radiation damage (E.g. on 50um sensor)

- Partly the performance can be recovered by increasing the bias Voltage applied to the diode ( $\sim 200\text{V} \rightarrow \sim 700\text{V}$ )
- **Reduction of gain and collected charge**
  - Charge collected up to 30fC (Gain  $\sim 50$ ) before irradiation to 1fC (gain 2-3) after a fluence of  $6\text{E}15 \text{ Neq}/\text{cm}^2$
  - (Neq: equivalent 1 MeV neutrons on  $\text{cm}^2$ )
- **Increased time resolution**
  - Time res. of 25ps to 60ps after a fluence of  $6\text{E}15 \text{ Neq}/\text{cm}^2$

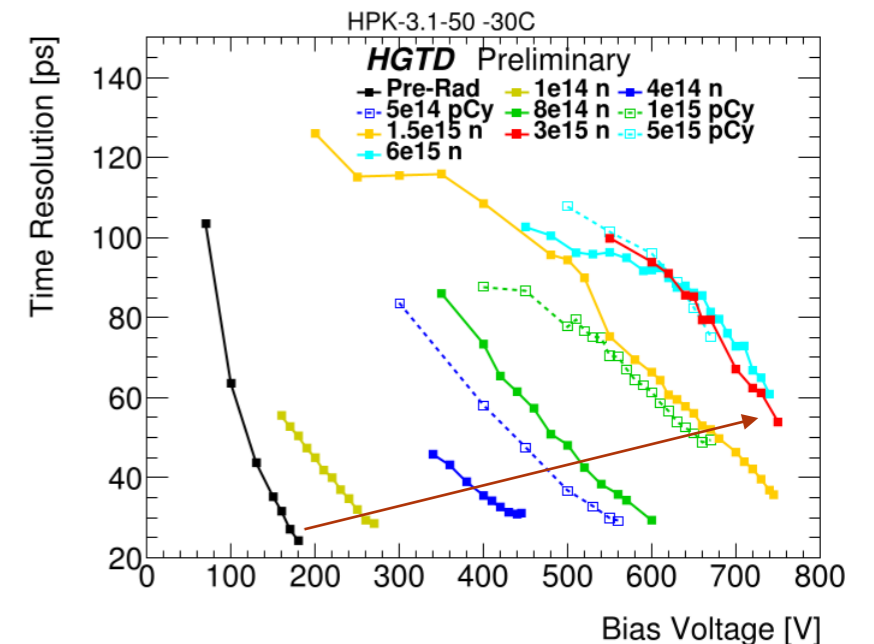
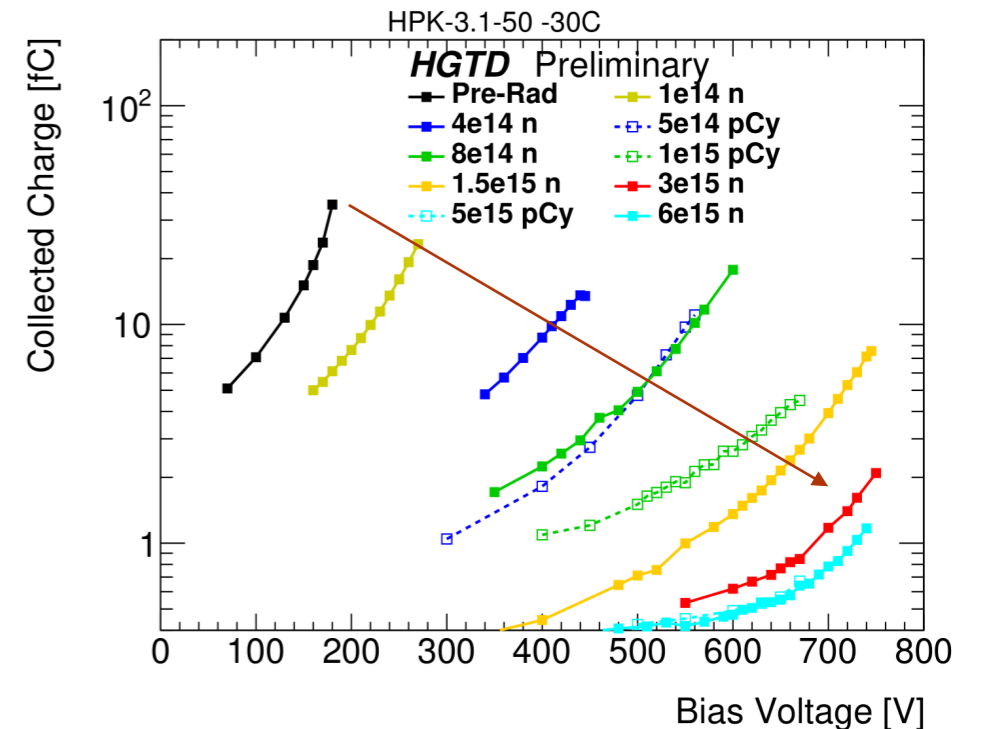

# Radiation hard LGAD design

Radiation hardness of LGADs can be increased by:

- **Thin but highly doped gain layer**
- **Addition of Carbon**
  - Carbon is electrically inactive (no effect pre-irradiation), catches interstitials instead of Boron, reduces acceptor removal after irradiation
- **Deeper gain layer**
  - High field for larger volume
  - Allows for better recovery of the gain from increased bias voltage after radiation damage
- The combination of all techniques (by FBK) allowed to **produce a sensor with gain ~20 at 2.5E15 Neq**
- **Resources**
  - <https://iopscience.iop.org/article/10.1088/1742-6596/2374/1/012173/meta>
  - <https://iopscience.iop.org/article/10.1088/1748-0221/15/10/P10003>
  - <https://www.sciencedirect.com/science/article/pii/S0168900218317741>
  - <https://doi.org/10.1088/1748-0221/15/04/T04008>
  - <https://doi.org/10.1016/j.nima.2018.08.040>

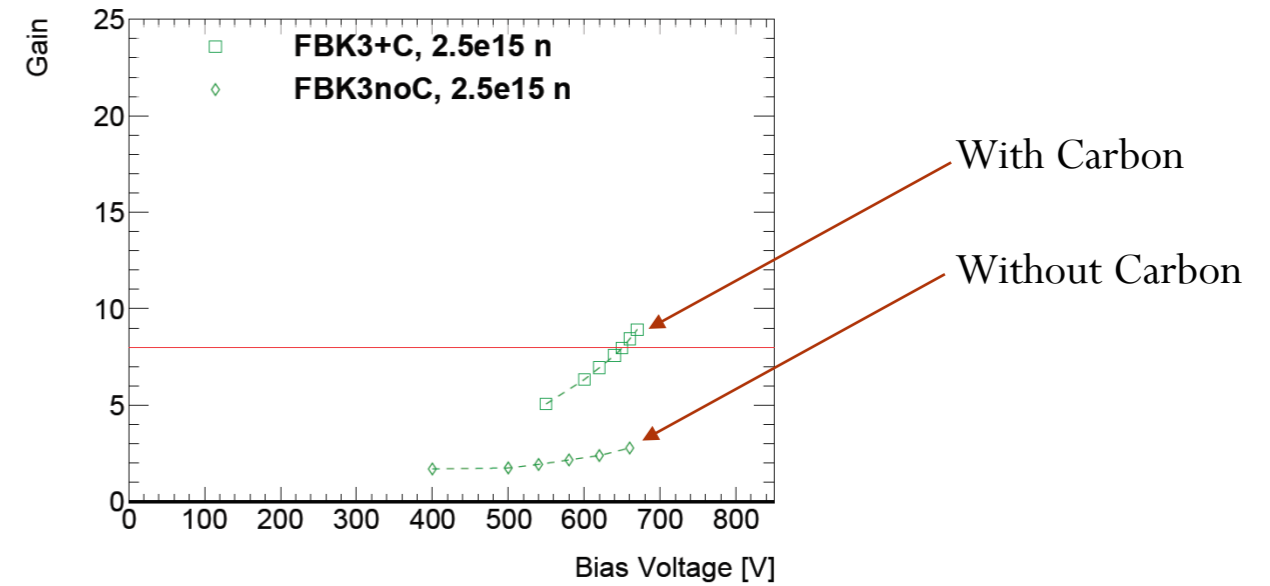

Deeper gain layer (triangles)  
Less deep gain layer (circles)  
(same color, same fluence)

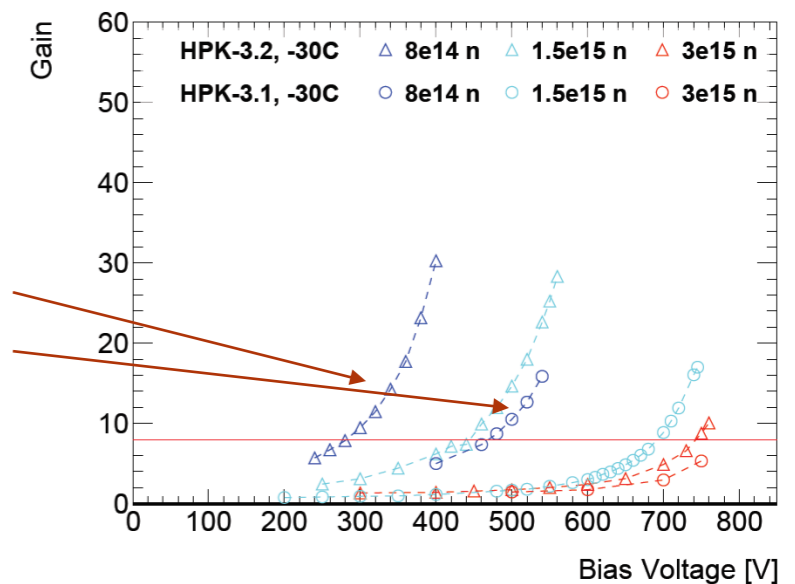

# FBK LGAD performance at maximum irradiation

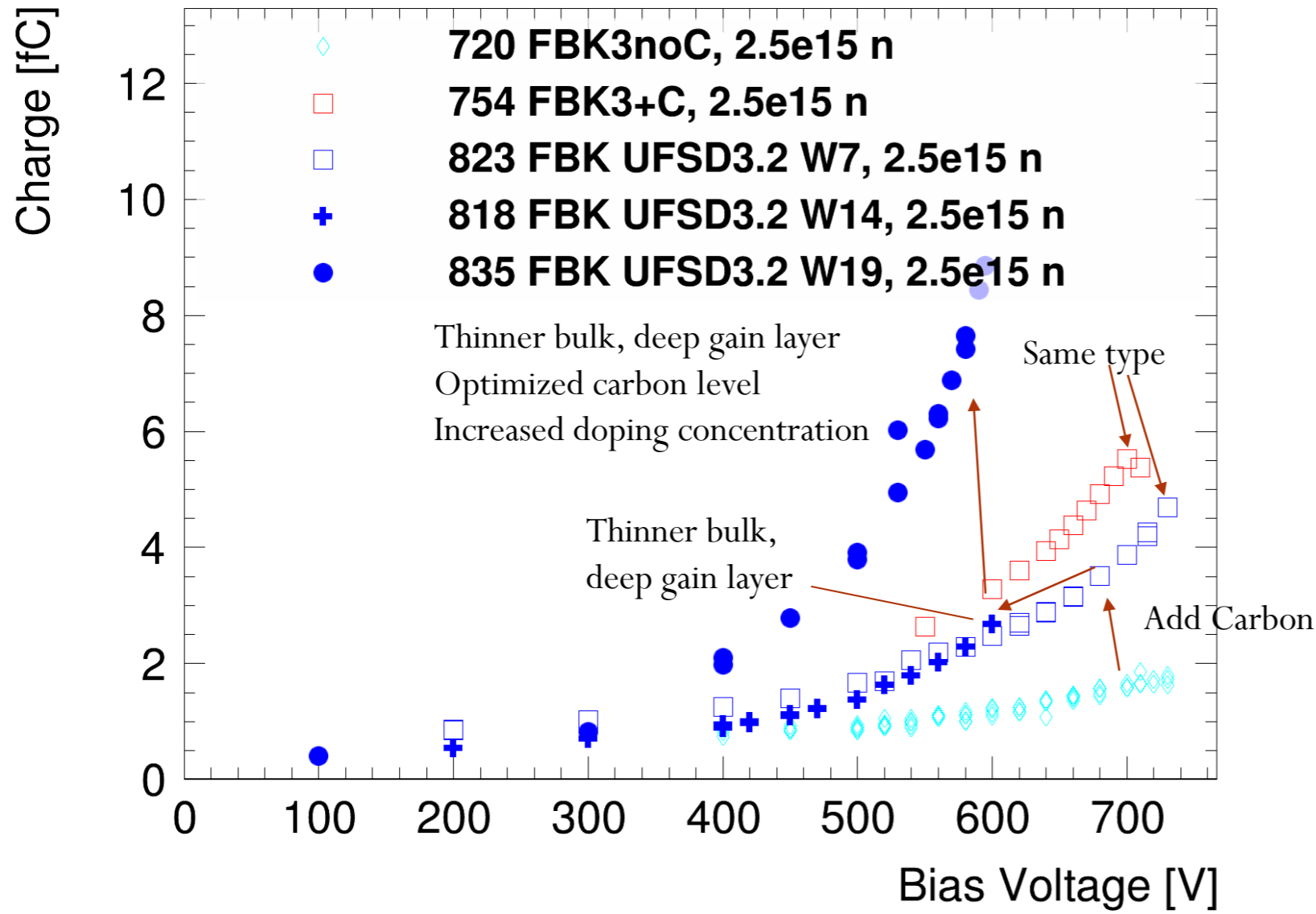

- **FBK UFSD3.2 sensors show the great potential of deep gain layer and Carbon implantation**
- FBK3noC (no carbon) has the worse performance
- FBK3+C and FBK UFSD3.2 (same structure with Carbon) have much better performance
- FBK UFSD3.2 W14 with deep gain layer is similar to FBK3+C but has thinner bulk
  - lower initial charge, but better time resolution
- FBK UFSD3.2 W19 (highly doped, deep gain layer, optimized Carbon) best performance
  - **W19 has a higher starting point in gain layer doping to increase the radiation reach**

[https://indico.cern.ch/event/983068/contributions/4223171/attachments/2191347/3703735/020221\\_TREDI\\_LGAD\\_radhard.pdf](https://indico.cern.ch/event/983068/contributions/4223171/attachments/2191347/3703735/020221_TREDI_LGAD_radhard.pdf)  
[https://indico.cern.ch/event/983068/contributions/4223173/attachments/2191413/3703863/17022021\\_MarcoFerrero.pdf](https://indico.cern.ch/event/983068/contributions/4223173/attachments/2191413/3703863/17022021_MarcoFerrero.pdf)  
[https://indico.cern.ch/event/983068/contributions/4223215/attachments/2192222/3705404/Siviero\\_TREDI2021.pdf](https://indico.cern.ch/event/983068/contributions/4223215/attachments/2192222/3705404/Siviero_TREDI2021.pdf)

# Radiation hardness for future colliders

- **New technology** needs to be developed for future colliders with **high radiation hardness requirements** ( $10^{16-17}$  Neq/cm<sup>2</sup>) and **high occupancy** (e.g.: FCC-hh)
- With R&D effort in ATLAS/CMS in  $\sim 6$  years **x10 improvement in radiation hardness**, up to  $2.5E15$  Neq/cm<sup>2</sup>
  - Need for order of magnitude increase in radiation hardness and higher granularity
- **Many efforts are ongoing to push the radiation hardness of LGADs**
  - Rad-hard timing electronics also needs to be developed hand-in-hand

Radiation hard

**Buried-LGAD**

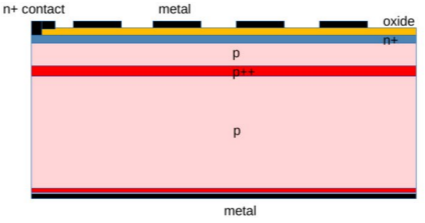

Carbon implantation  
Carbon shielding

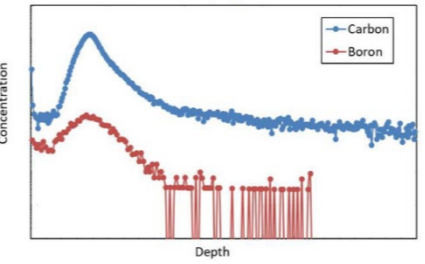

Inactive Boron,  
Low diffusion

**Compensated gain layer**

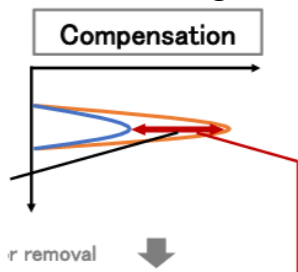

Both p and

**3D trenches**

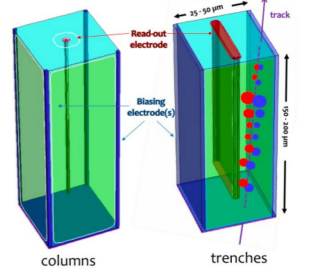

**Adaptive gain layer**

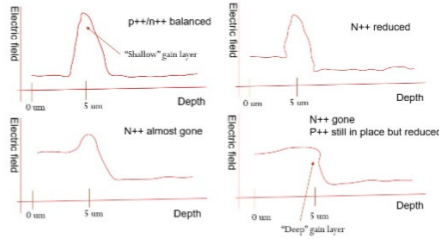

LGAD CMOS

# III. High granularity LGADs

---

Granularity challenge

# LGAD arrays structure

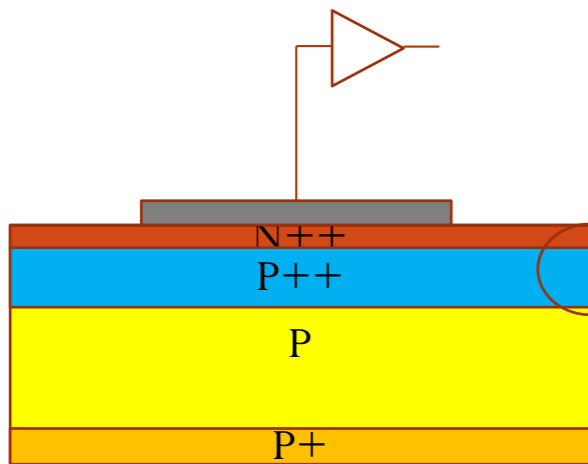

Very high field area, induces early breakdown

Structure to avoid high field line concentration at the edges  
 Junction Termination Extension (JTE)  
 Separation between the pads of an array  $\sim 50\text{-}100\ \mu\text{m}$

- Protection structures limit the current granularity of LGADs
- $\sim 100\ \mu\text{m}$  pixel size would mean  $\sim 50\%$  active area
- But intensive R&D is ongoing to overcome this limitation

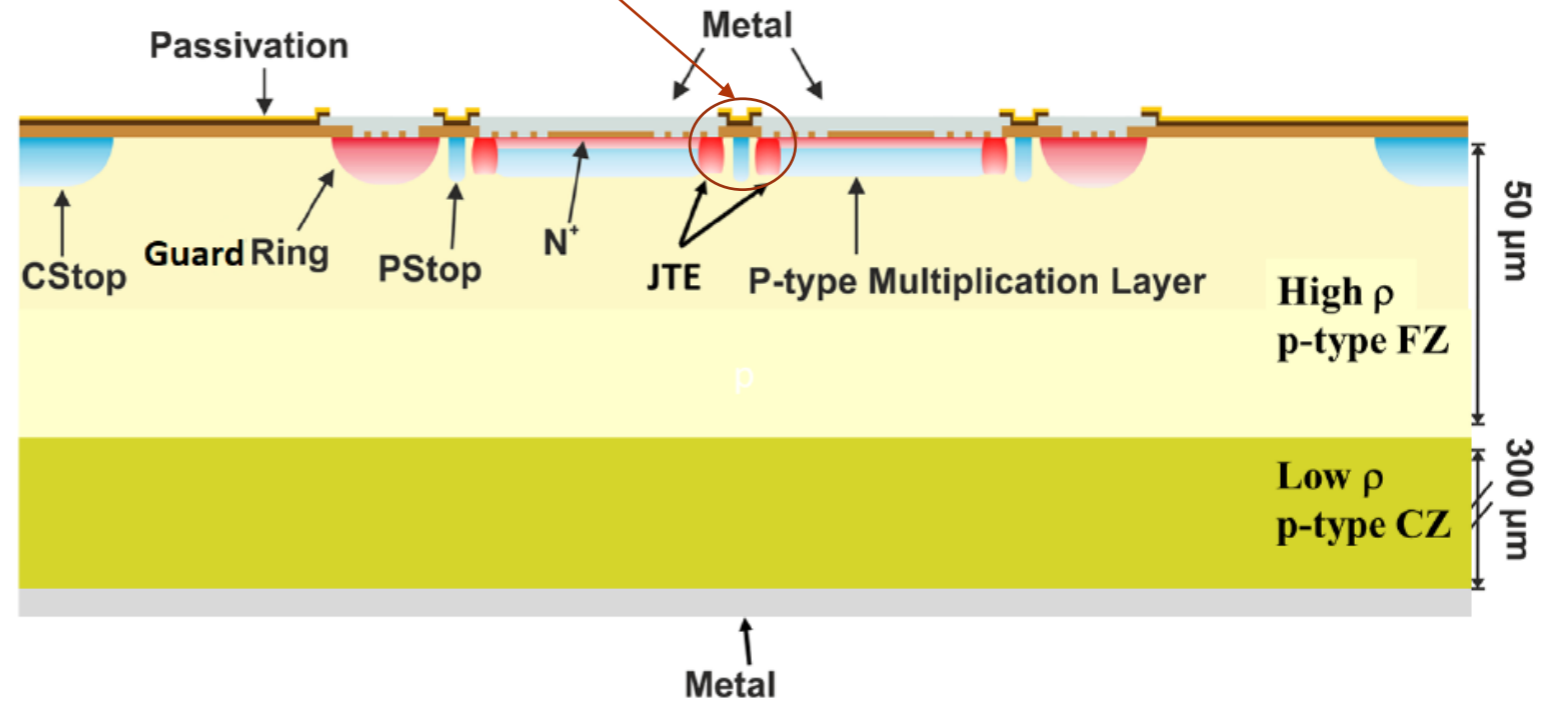

# High granularity LGADs

- First LGADs relatively new (6-7 years ago)
- **Many recent innovative prototypes to increase LGAD granularity**

Std LGAD

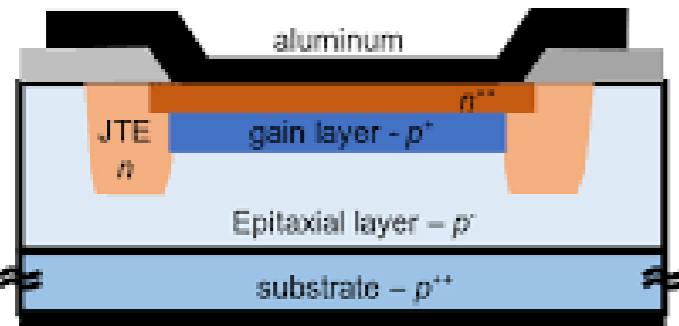

Traditional LGAD

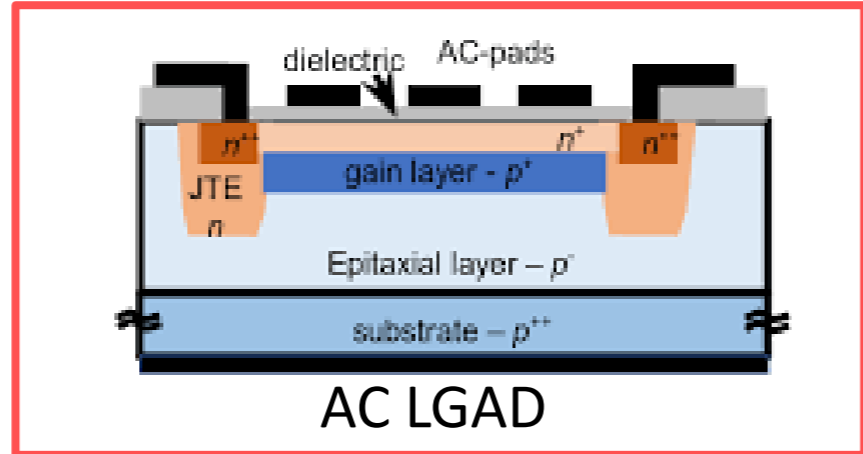

AC LGAD

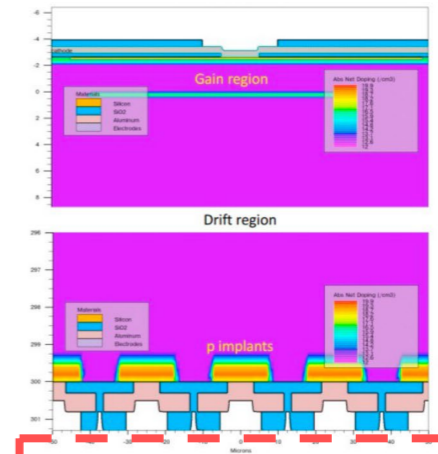

High granularity

DS-LGAD

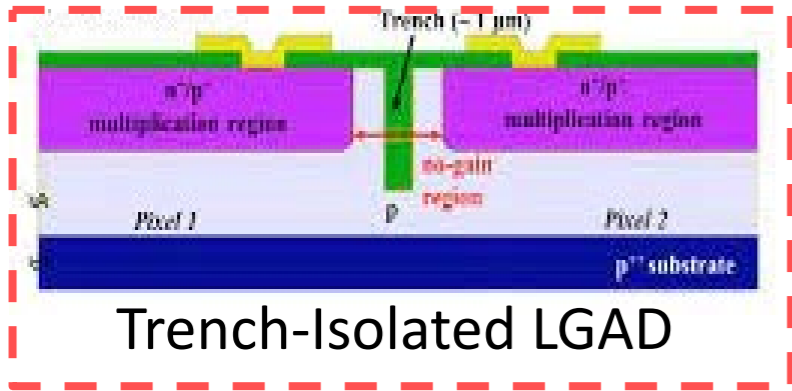

Trench-Isolated LGAD

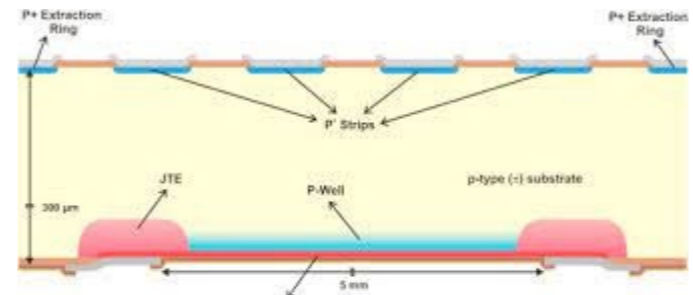

Inverse LGAD

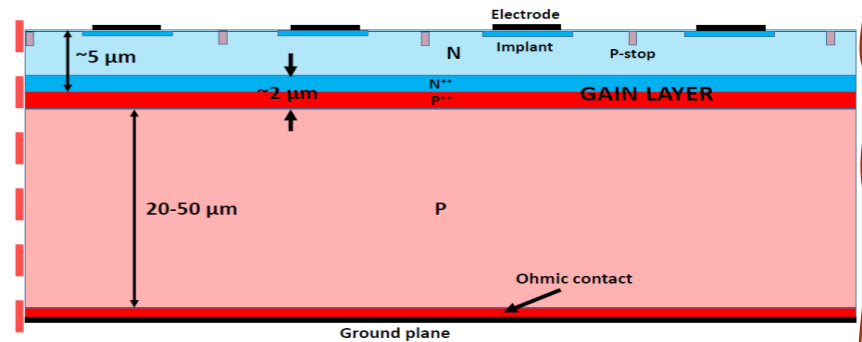

Deep-Junction LGAD



# AC-LGADs

- Most advanced prototype are AC coupled LGAD
  - Finer segmentation and easier implantation process
- Continuous sheets of multiplication layer and N+ layer
- N+ layer is **resistive** and grounded through side connections
- **Readout pads are AC-coupled**
  - Insulator layer between N+ and pads
- Prototypes produced by CNM, FBK, BNL, HPK

- **The response of the sensors can be tuned** by modifying several parameters
  - Pad geometry and dimension
  - Pad pitch
  - N+ layer resistivity
  - Oxide thickness

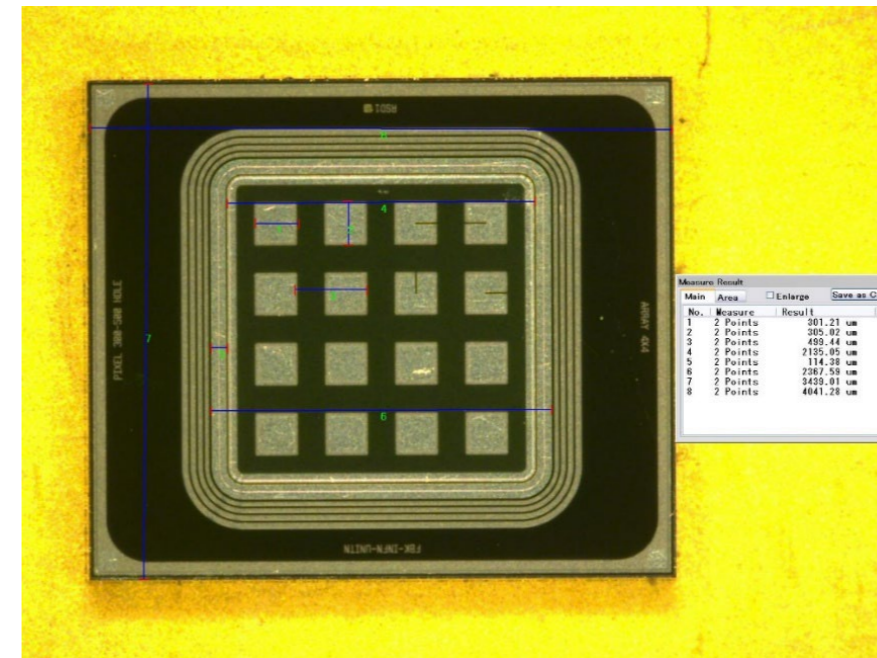
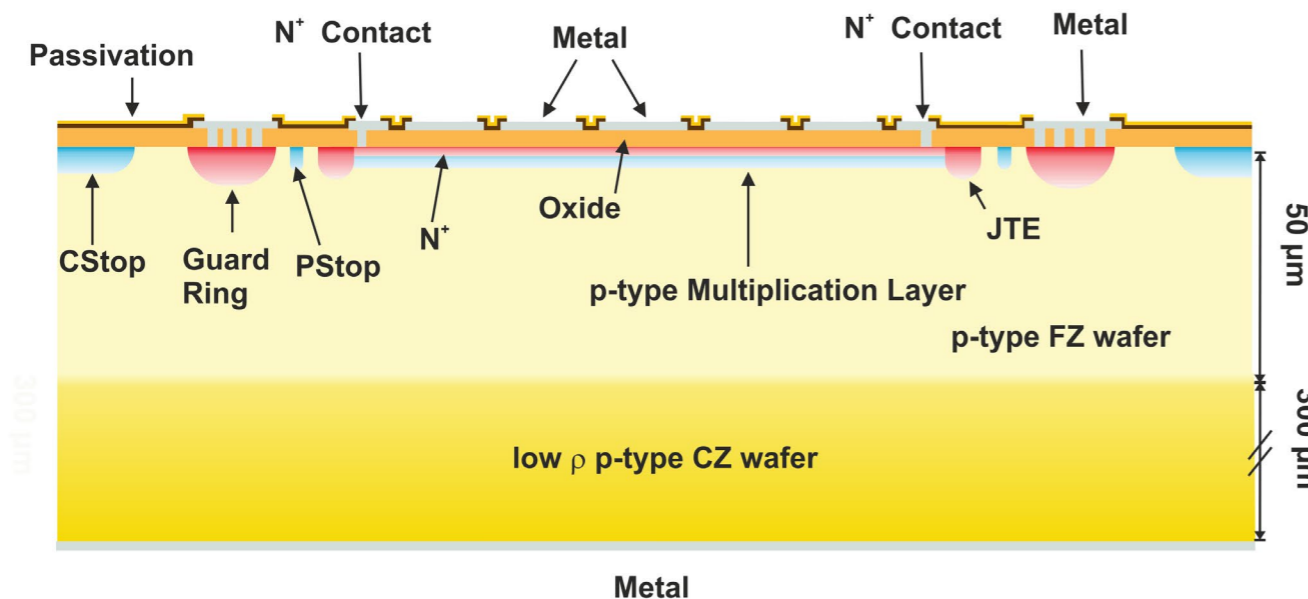

# AC-LGAD hit reconstruction

- AC-LGAD has **intrinsic charge sharing**
  - Gain increases the S/N and allows for smaller metal pads
- Charge sharing can be a great feature for low density tracking environment
  - Using information from multiple pixels for hit reconstruction
- **With a sparse pixelation of 300  $\mu\text{m}$  a  $<10 \mu\text{m}$  hit precision can be achieved!**
  - Combination of time of arrivals as well
- **Sparse readout is extremely useful for channel density and power dissipation**
- Metal layout can be in any shape and size
- Technology being consider for
  - The PIONEER experiment at PSI
  - ePIC, future detector at Electron-ion collider (EIC) at BNL

References:

<https://indico.physics.lbl.gov/event/1262/>

<https://indico.cern.ch/event/918298/contributions/3880516/>

<https://arxiv.org/abs/2006.01999>

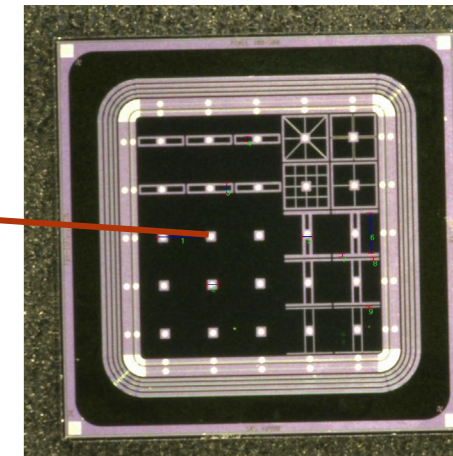
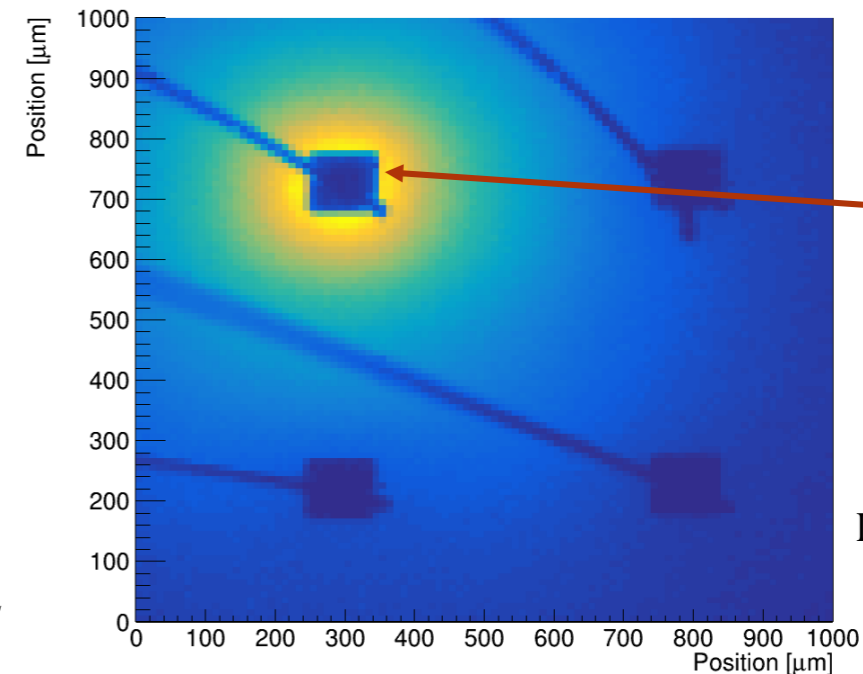
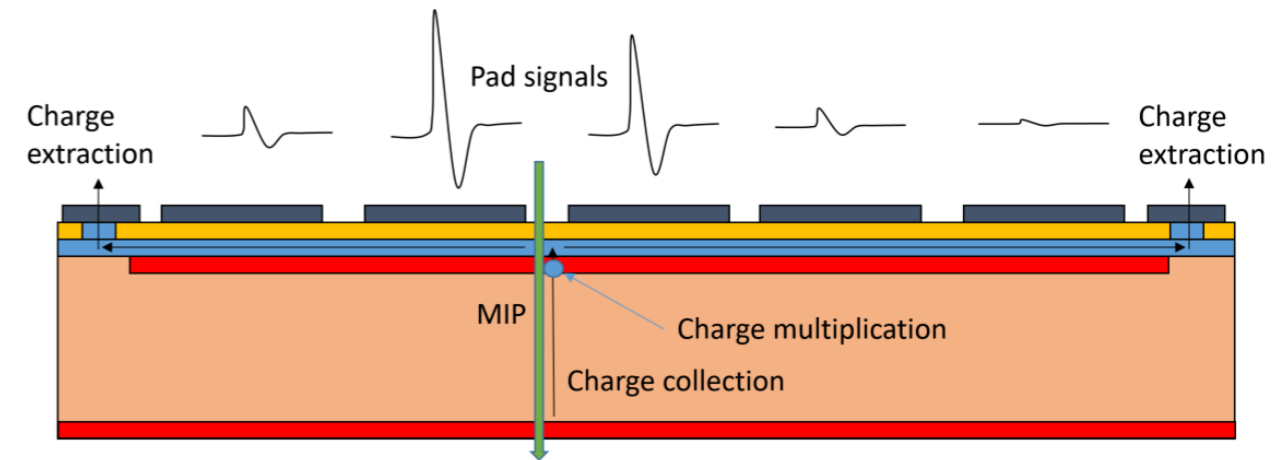

IR laser scan of the device

# AC-LGAD strips studies

- BNL strip AC-LGADs with same geometry but different lengths
- Pitch and width in three configurations (width = pitch/2)
  - 300-150  $\mu\text{m}$ , 200-100  $\mu\text{m}$ , 100-50  $\mu\text{m}$
  - 0.5 cm and 1 cm long sensors
- 2.5 cm long sensor with strips of 500-200  $\mu\text{m}$ 
  - Charge sharing present up to  $\sim 2\text{mm}$
- Direct comparison of geometry shows that **longer strips have increased charge sharing**, also depending on strip pitch/width
- Position resolution is similar in the 4 sensors in the center between strips, increases under the strip
  - **Position resolution is  $\ll$  than pitch/ $\sqrt{12}$ !**

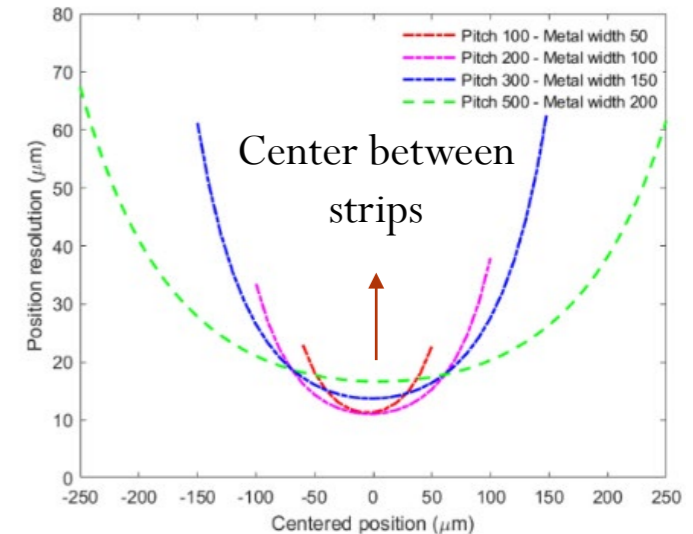
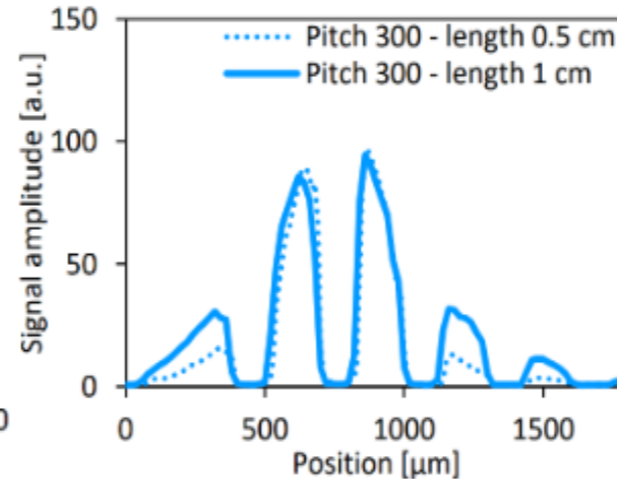
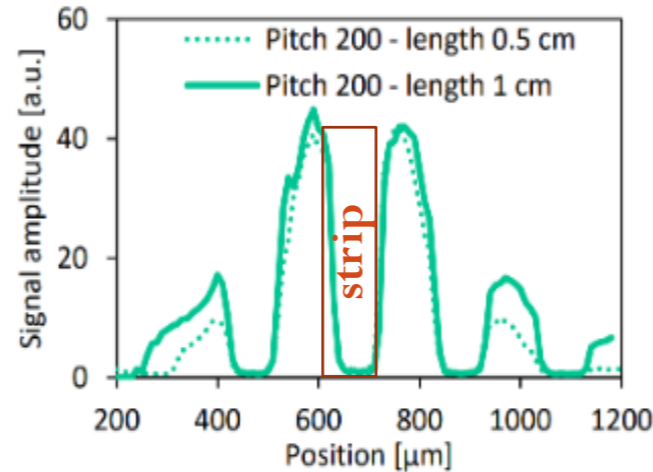
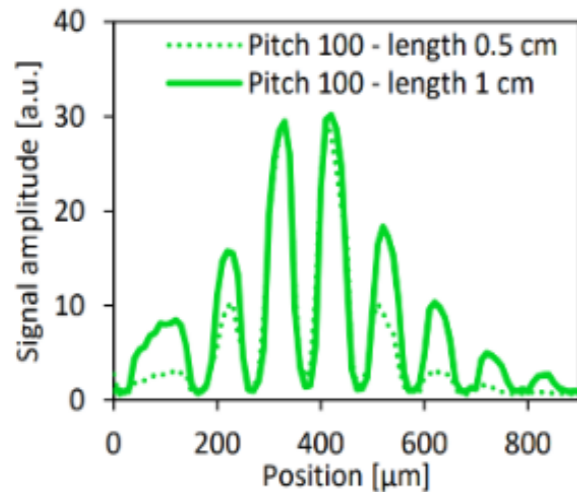
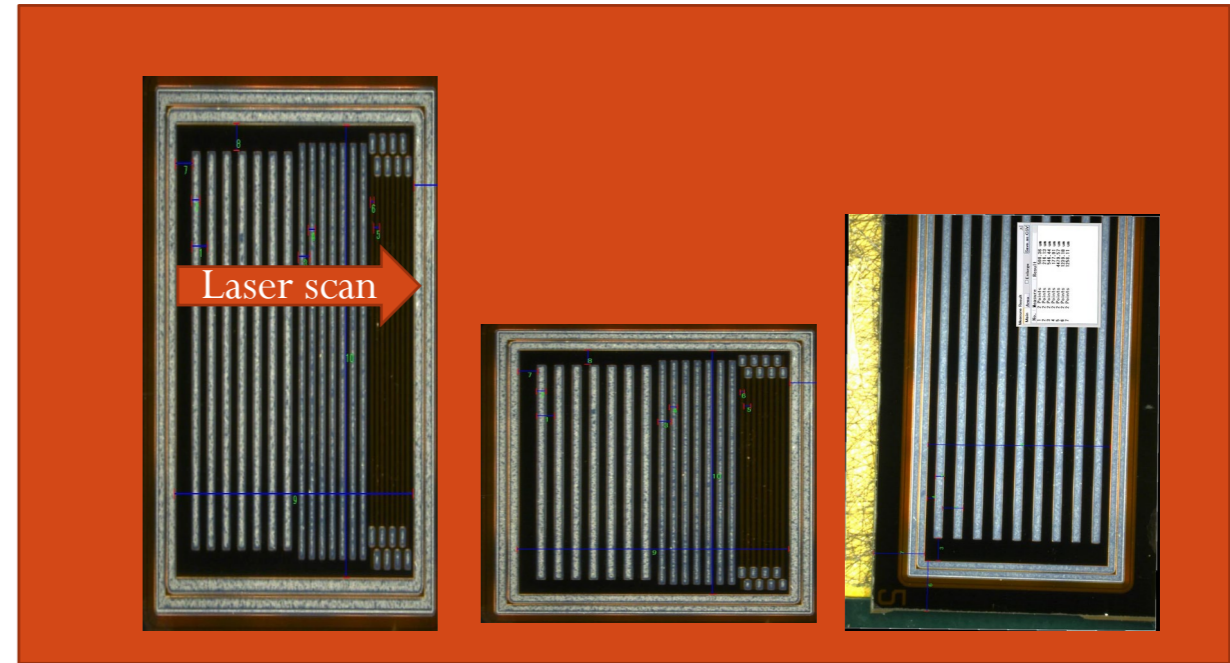

Response of one strip, data taken with IR laser (metal strips are opaque)

# Other high granularity LGAD technologies

- **Trench insulated LGADs (TI-LGAD)**
- Pads insulated by deep trenches filled with oxide
- First prototypes successfully produced by FBK:
  - <https://indico.cern.ch/event/861104/contributions/4514658/>
- Very good performance observed!
  - IP gap 5-10  $\mu\text{m}$  or less
- Similar granularity as regular silicon sensors

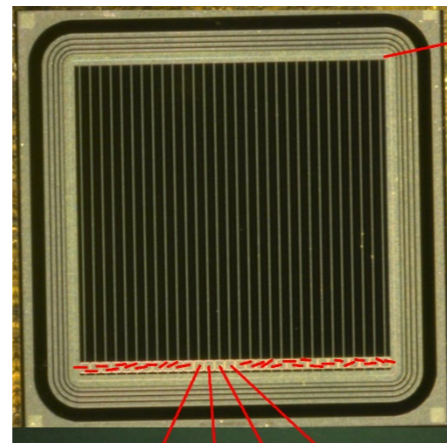
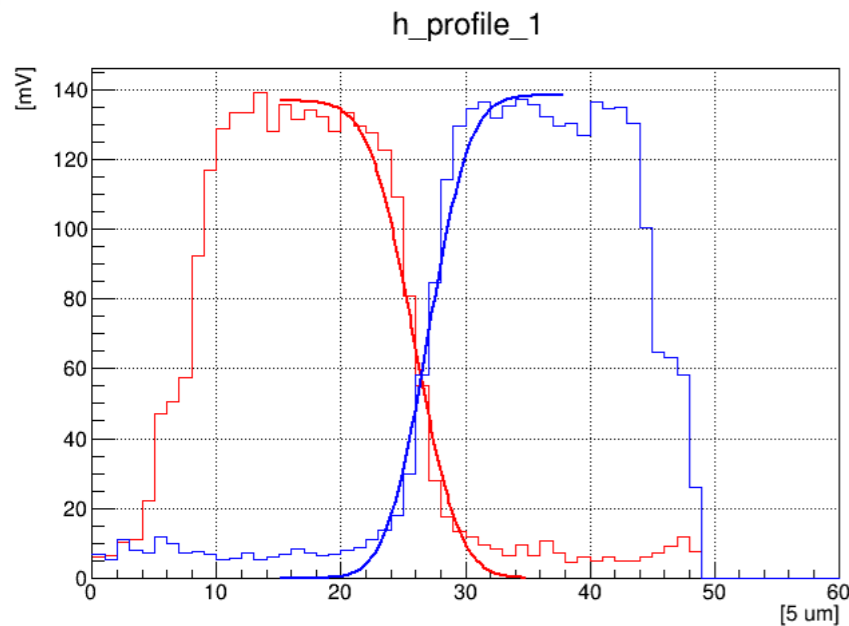

Prototype FBK TI-LGAD

- **Deep-Junction LGAD (DJ-LGAD)**
- Gain layer is buried, so the top can be segmented as in normal silicon detectors
  - <https://arxiv.org/abs/2101.00511>
- **First production completed** by Cactus material in collaboration with BNL and UCSC
  - Promising performance (gain of  $\sim 5$ ) and good pad insulation (few  $\mu\text{m}$  IP gap)
- Similar granularity as regular silicon sensors

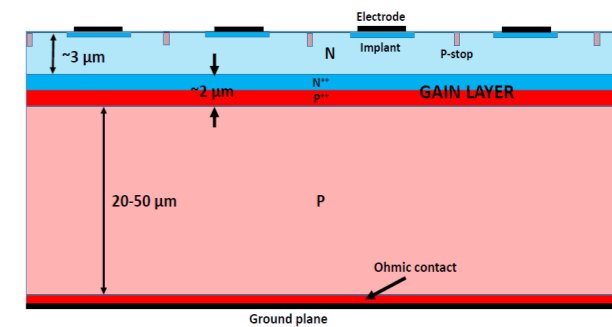
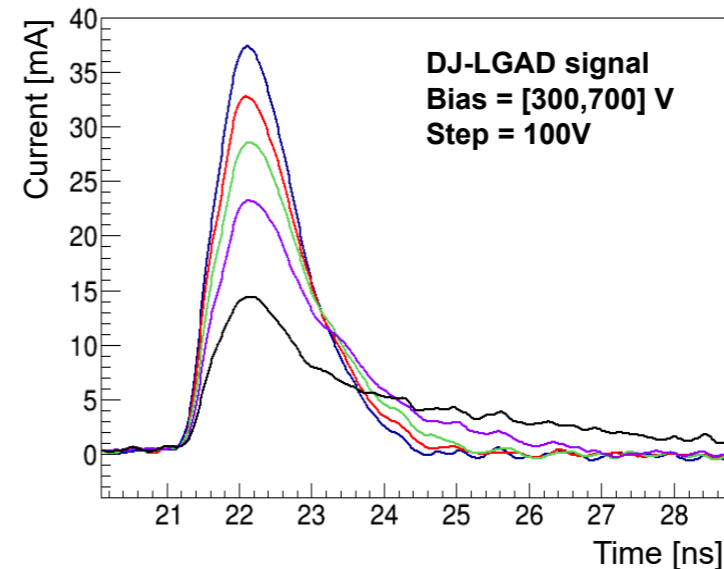

# IV. LGADs application in HEP and NP

---

# ATLAS and CMS timing layers

- First application of LGADs in HEP experiments at HL-LHC ( $\sim 2027$ )
  - **Timing layers in the end-cap (forward) region to mitigate pile-up**
- **ATLAS High Granularity Timing Detector (HGTD)**
  - <https://cds.cern.ch/record/2719855>
- LGAD requirements for HGTD:
  - Radiation hardness to  $2.5E15\text{Neq}$ ,  $4\text{MGy}$
  - Time resolution  $< 50\text{ps}$  per hit, collected charge  $\sim 10\text{fC}$
  - Power (sensor-only)  $< 100\text{mW}/\text{cm}^2$
- As of now we have prototypes that satisfy and exceed these requirements!
- **CMS Endcap Timing Layer (ETL)**
  - <https://cds.cern.ch/record/2667167>
  - CMS will also feature a timing layer in the barrel but with different technology (LYSO bars + SiPM readout)

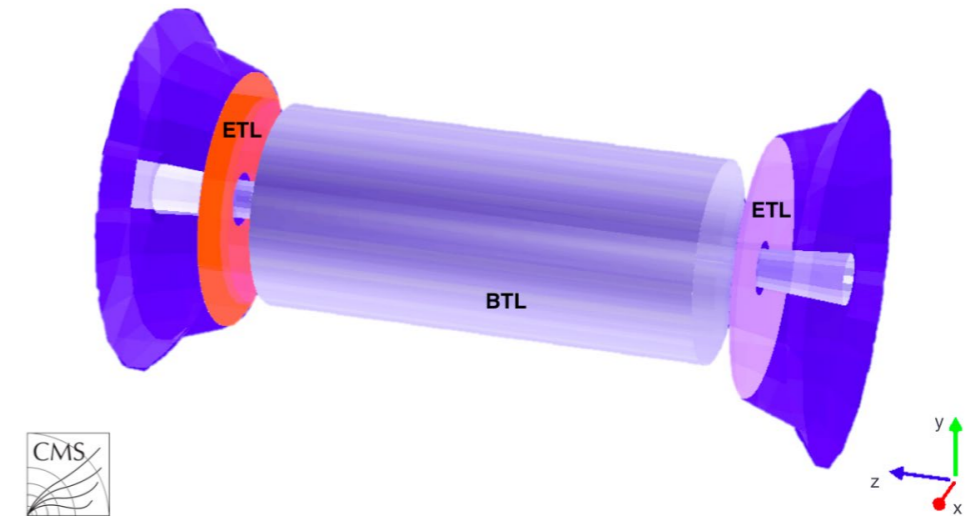
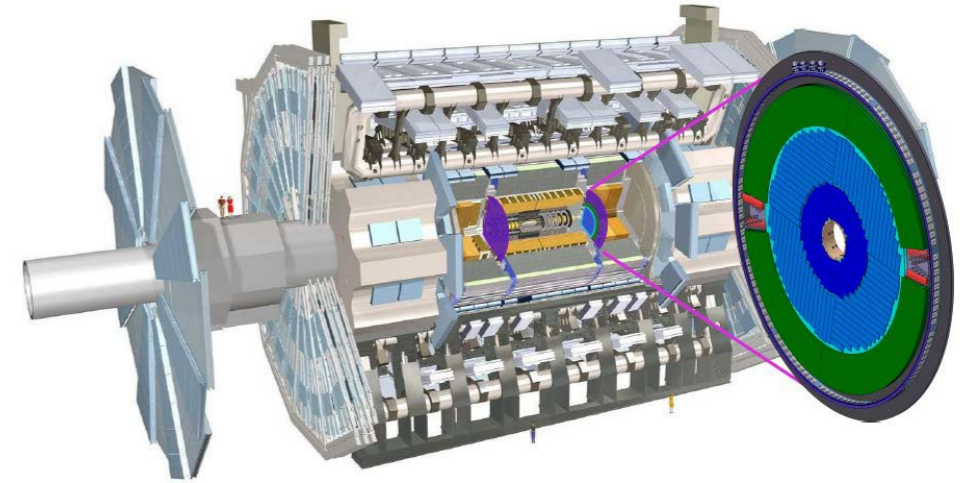

# PIONEER

- **PIONEER** is a new rare pion decay experiment at PSI
  - <https://arxiv.org/abs/2203.01981>
- The goal is to **improve the precision of  $R_{e/\mu}$  and  $B(\pi^+ \rightarrow \pi^0 e^+ \nu)$**  by an order of magnitude
  - $R_{e/\mu}$  is the ratio of pion decay to electron a muon: precision measurement of **lepton flavor universality**
  - $B(\pi^+ \rightarrow \pi^0 e^+ \nu)$  is the cleanest measurement of  $V_{ud}$ : very important to test **CKM matrix unitarity**
- PIONEER will feature a high granularity, time resolved fully silicon active target (a 5D tracker!)
  - ‘Live’ tracking of pion decay to see positron and muon decay channels
  - **Based on LGAD timing technology**
  - <https://www.mdpi.com/2410-390X/5/4/40>

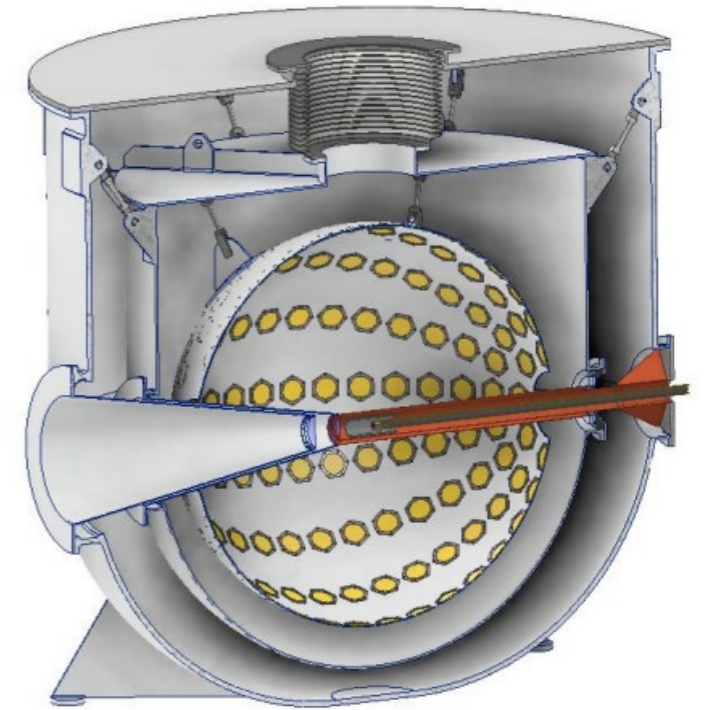
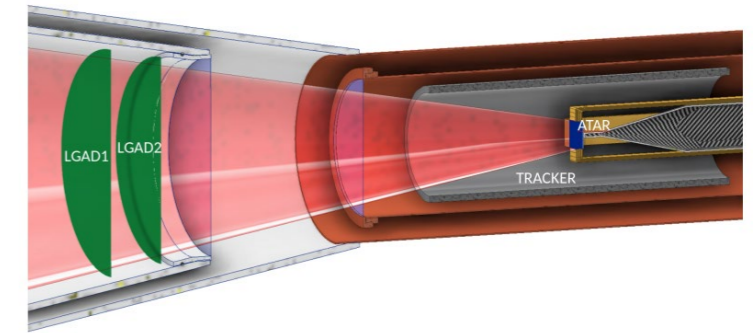

# Electron-Ion collider (<https://www.bnl.gov/eic/>)

- 4D tracking will be used in the EPIC detector
- **AC-LGAD** is foreseen for both barrel and end-cap in EPIC
  - 500  $\mu\text{m}$  x 1 cm strip,  $\sim 1\%$  X0 for **barrel**
  - 500 x 500  $\mu\text{m}$  pixel, 8% X0 for **forward**
  - 25 ps single hit time resolution
  - $\sim 30 \mu\text{m}$  spatial resolution
- **Particle identification with time of flight (TOF)**
  - For  $e/\pi/K/p$  at low/intermediate momentum
- Require good time resolution and meaningful flight distance
  - Better with  $4\pi$  coverage for  $t_0$  determination
- E.g. around 30 ps at 0.5m (70ps at 1m) is required to have PID with momentum  $< 0.5 \text{ GeV}$  in the barrel

[https://indico.bnl.gov/event/13566/contributions/56042/attachments/38002/62629/LGADsConsortium\\_EIC\\_WeiLi\\_11012021\\_v1.pdf](https://indico.bnl.gov/event/13566/contributions/56042/attachments/38002/62629/LGADsConsortium_EIC_WeiLi_11012021_v1.pdf)

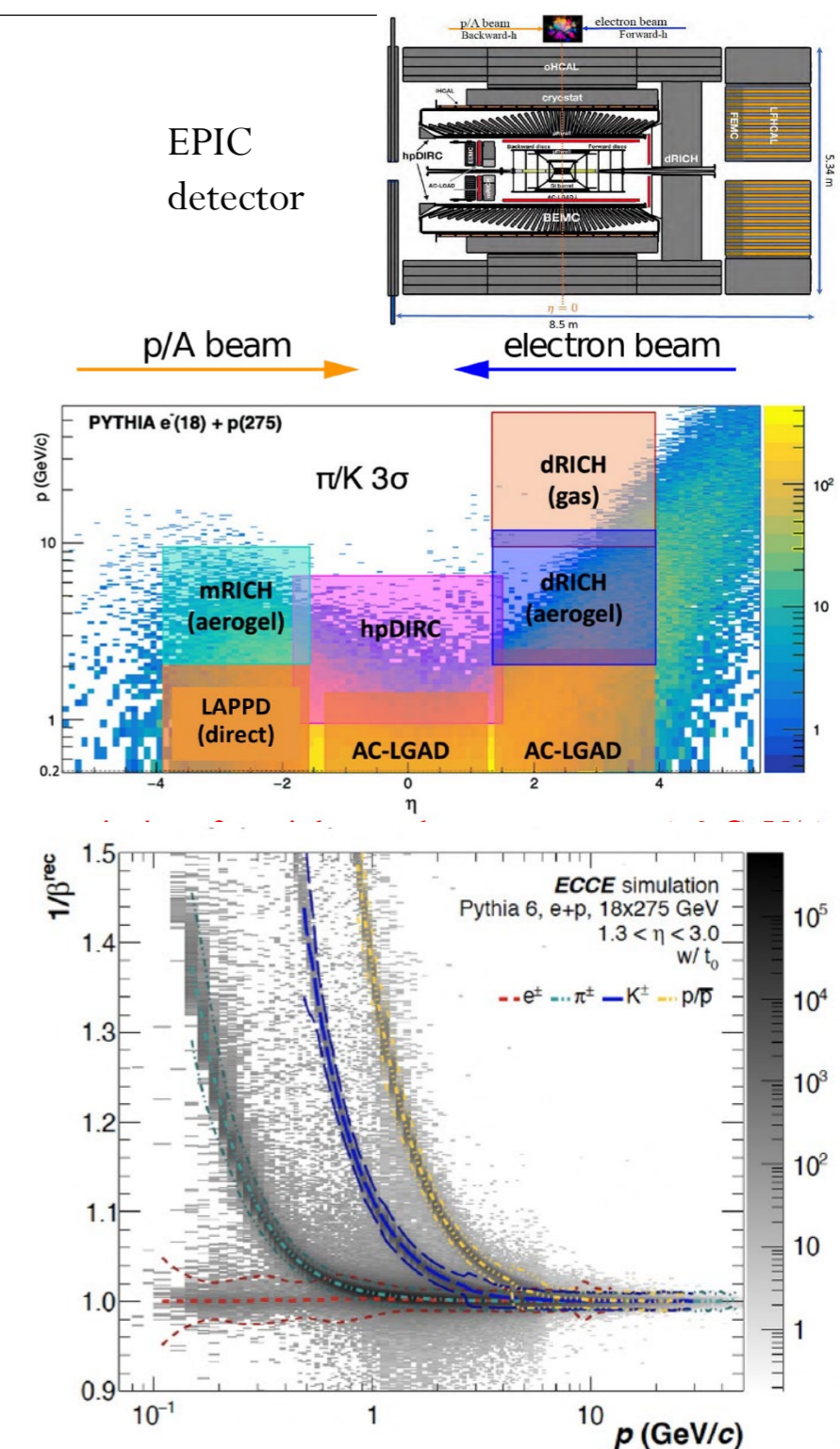



# V. X-ray detection with LGADs

---

# X-rays detection with LGADs



- LGAD tested for X-ray detection at the **SLAC** Stanford Synchrotron Radiation Light source (**SSRL**)
  - Last test beam in November 2022, BL 11-2
- X-rays of energy range [5, 70] KeV
  - 50 um and 20 um thick detectors
- 50 um LGAD full collection time  $\sim 1$  ns (can push to GHz repetition rate)
  - Definite pulses even with a **2 ns beam separation**
  - Small influence on shape from close-by pulses
- Results on <https://arxiv.org/abs/2306.15798> (submitted to JINST)

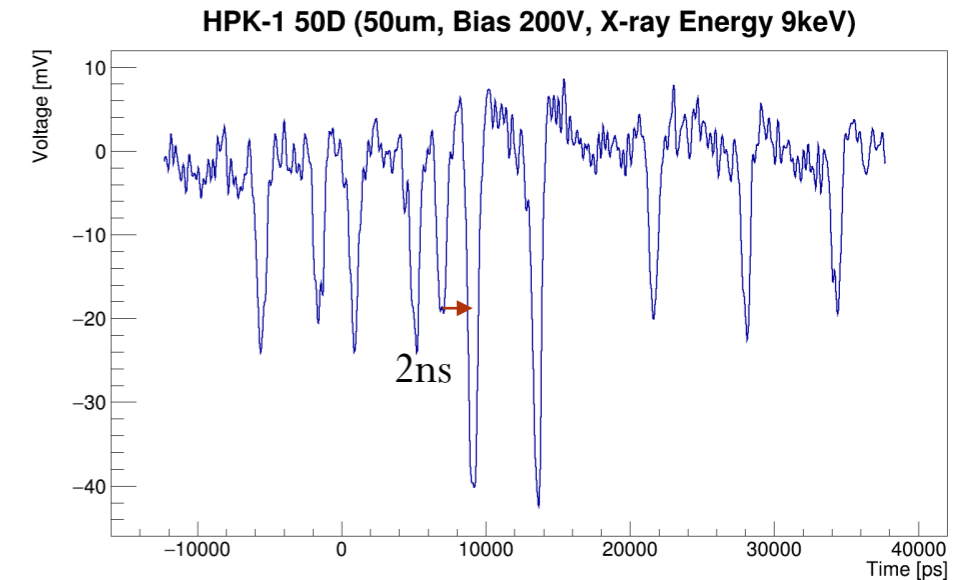

# X-rays detection with LGADs

- Linearity and the energy resolution of different LGADs at different bias voltages
  - Good linearity, best energy resolution at lower voltages (low gain) of  $<10\%$
  - Thin PiN (no gain) device has energy resolution 10-15%
- **Time resolution 100-150 ps**: higher than MiP affected by X-ray interaction
- Shown results for HPK 3.1 (ATLAS HGTD production)
  - Tested AC-LGAD strip devices as well, energy resolution 10-20%

Why is PiN better at time resolution?  
See next slide!

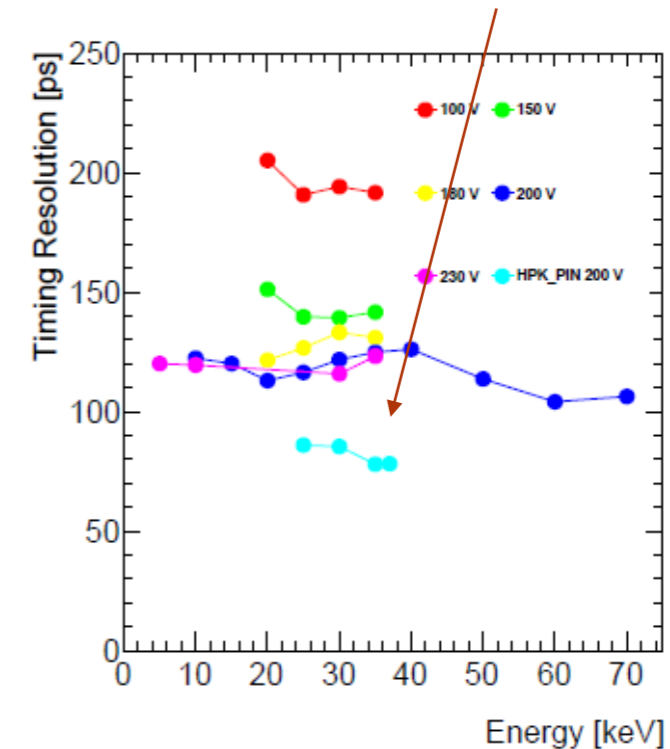
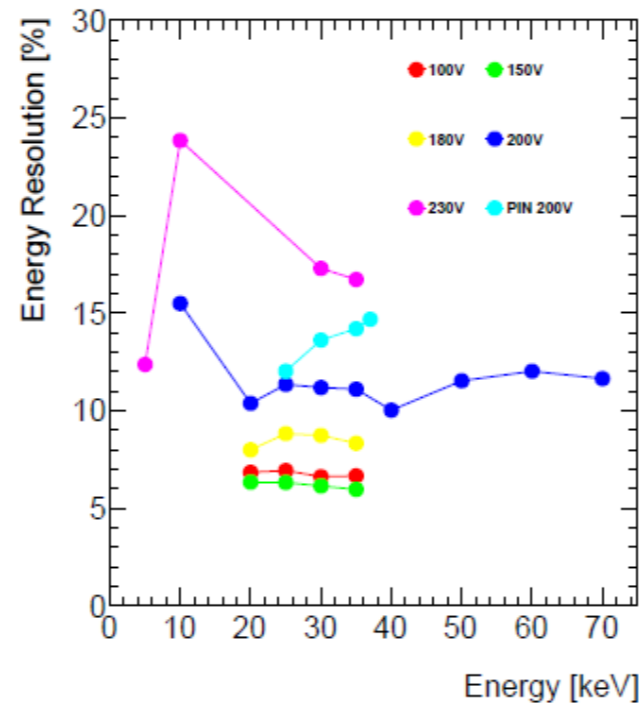
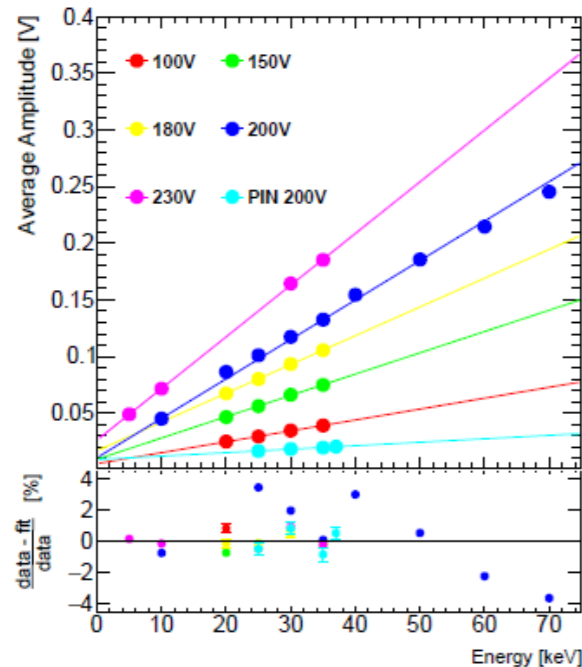

# X-rays detection with LGADs

- X-ray interactions at different absorption depth in the LGAD: simulate with TCAD Sentaurus
  - Initial “flat top” of the pulse because of charge travel to the gain layer, delaying the gain process
- Observed the same behavior in the data
- This doesn't happen in the PiN since current is instantaneous

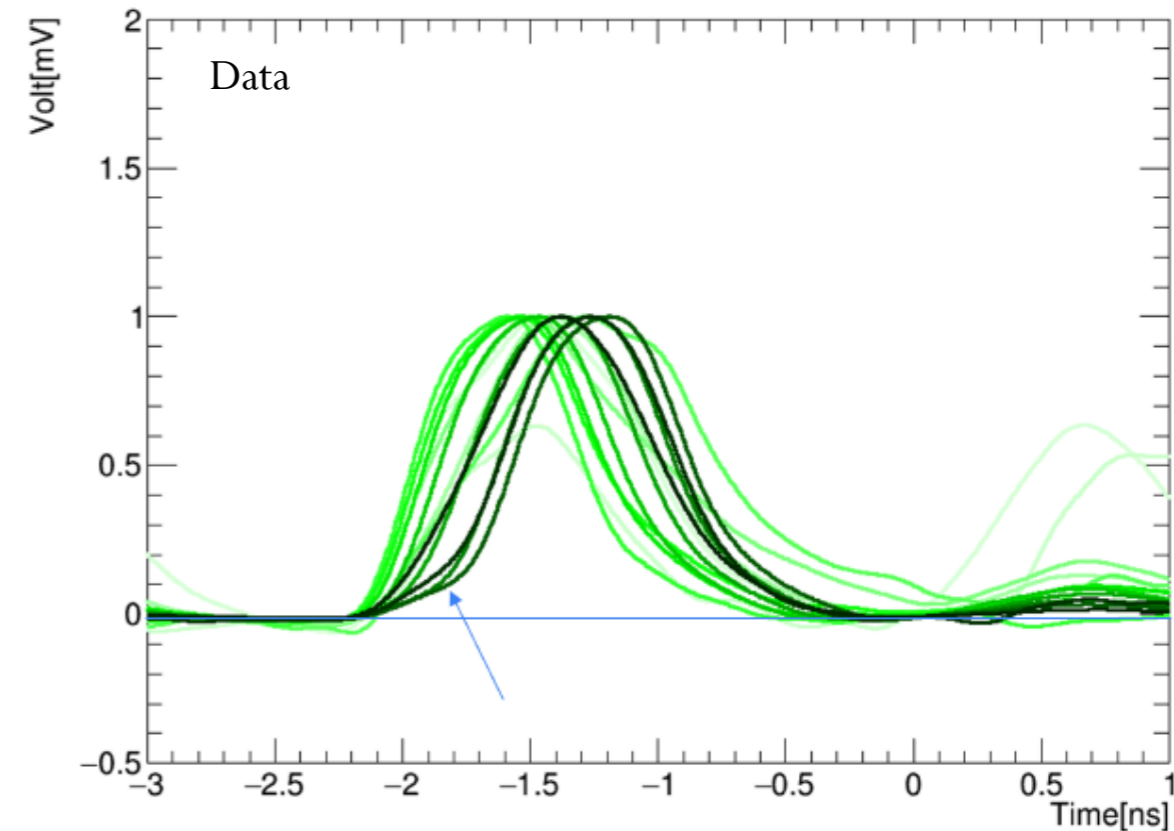
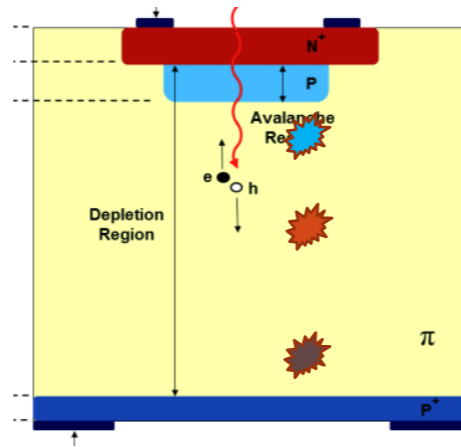
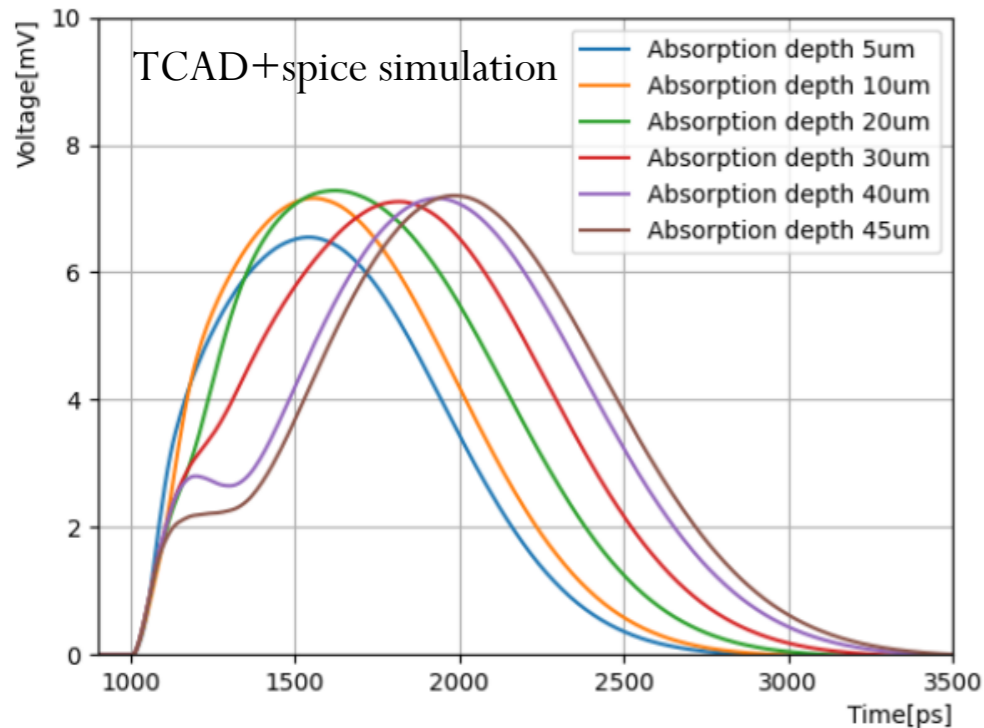

(b) Convolved voltage signal with TIA.

# VI. Gain saturation

---

Gain challenge

# Gain saturation

- **LGAD gain suppression mechanism** being studied recently (<https://indico.cern.ch/event/983068/contributions/4223231/>)
  - Gain suppression observed experimentally with large energy depositions
  - Caused by the field shielding effect from the gain electrons/holes
  - Tested by many groups with an ion beams, lasers, alpha sources etc...
- Just tested at CENPA's (University of Washington) ion accelerator
  
- **Effort to try and minimize this effect**
- Explore and characterize the gain suppression effects using **TCAD simulation**
  - Significant gain loss for high gain detector and high deposition
- **Simulation shows that with a low gain sensor the gain reduction is less**
  - Gain suppression can be reduced with adjustment in the sensor design
  - See: <https://indico.bnl.gov/event/17072/contributions/70497/>

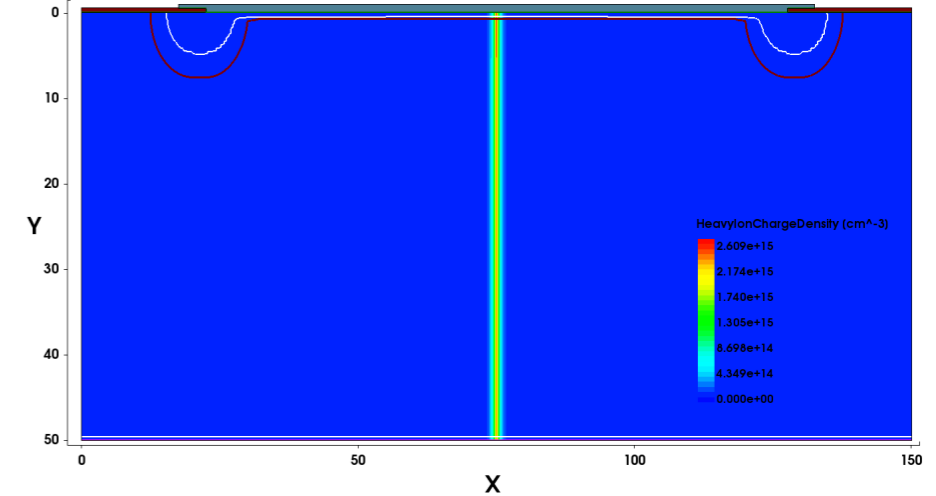

Gain suppression simulated with Sentaurus

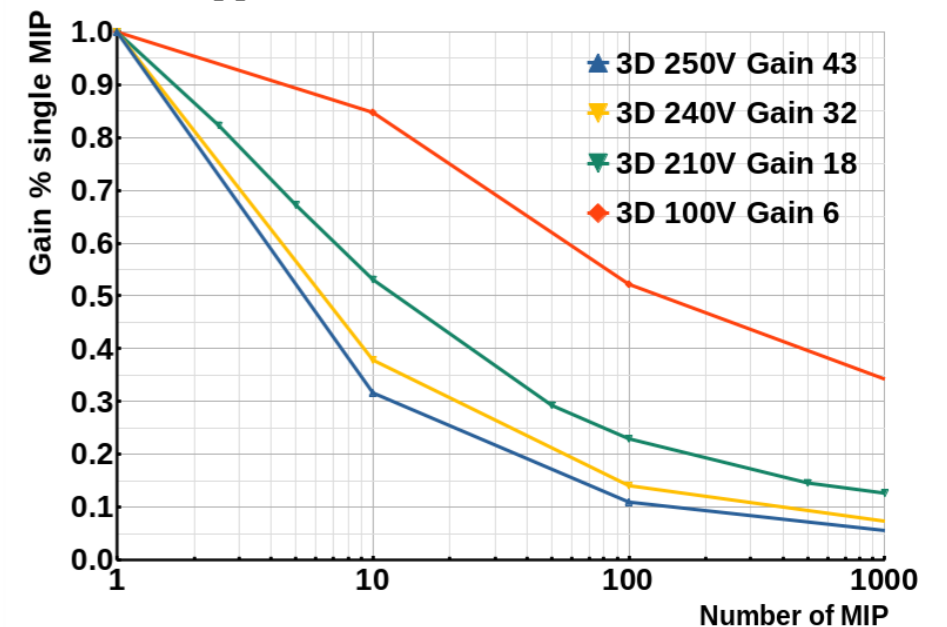

# Recovery (Relaxation) time of Electric Field

- Change in electric field in time and space
  - The effect is local (range of 5  $\mu\text{m}$ ) and the Electric fields returns to normal in few 100s of ps
- **Recovery (relaxation) time:** the required time duration for the electric field within the gain layer to recover to steady state after the impact ionization process

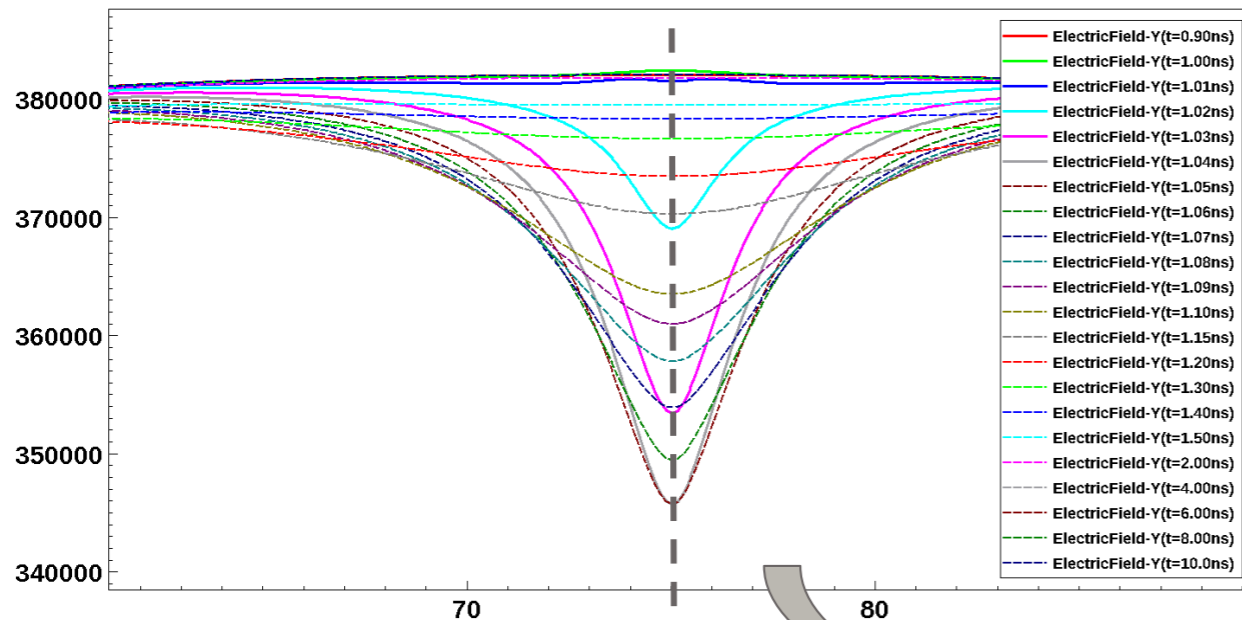

Snapshot of the electric field within the gain layer at different time for localized input charge.

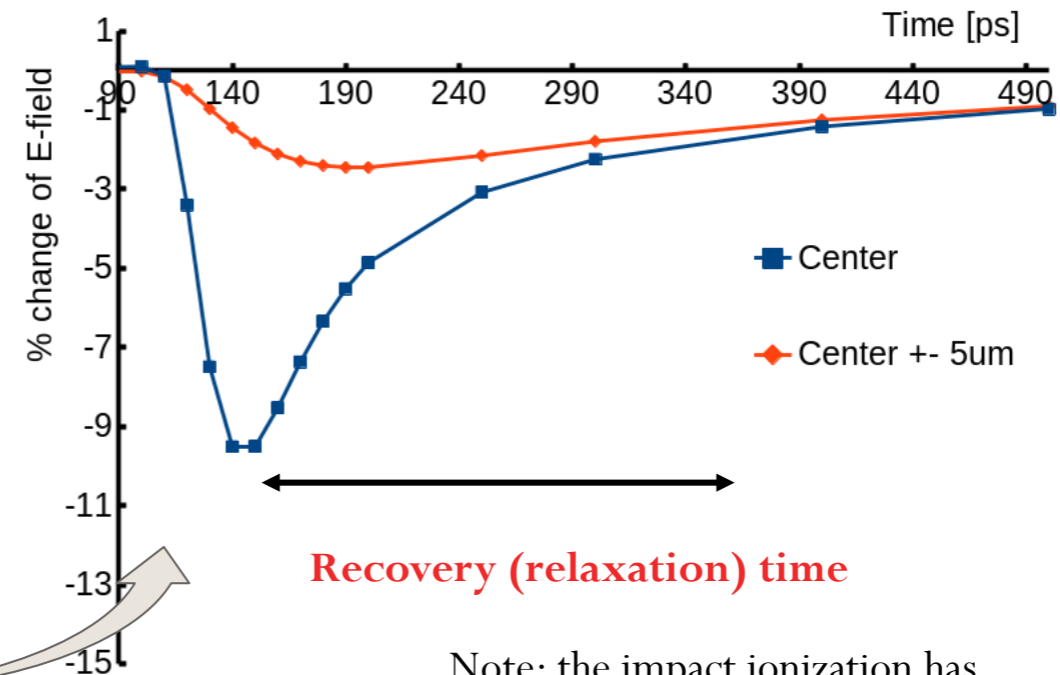

Note: the impact ionization has exponential dependence on the field.

# Improving the Recovery Time

- The recovery time of the electric field depends on how fast the generated charges from impact ionization process are “drain” away.
- One approach is to **increase the conductivity of the gain layer profile configuration**. E.g. increasing the n++ doping concentration.
  - No more changes above doping of  $5e21$  N/cm<sup>3</sup>
  - Reach limitation from transport of space charge in the gain layer itself.
- Another option: **increase the area where the multiplication happens** (deeper gain layer but lower field)
- Or spread out the charge as it gets collected: simulations and data taking ongoing

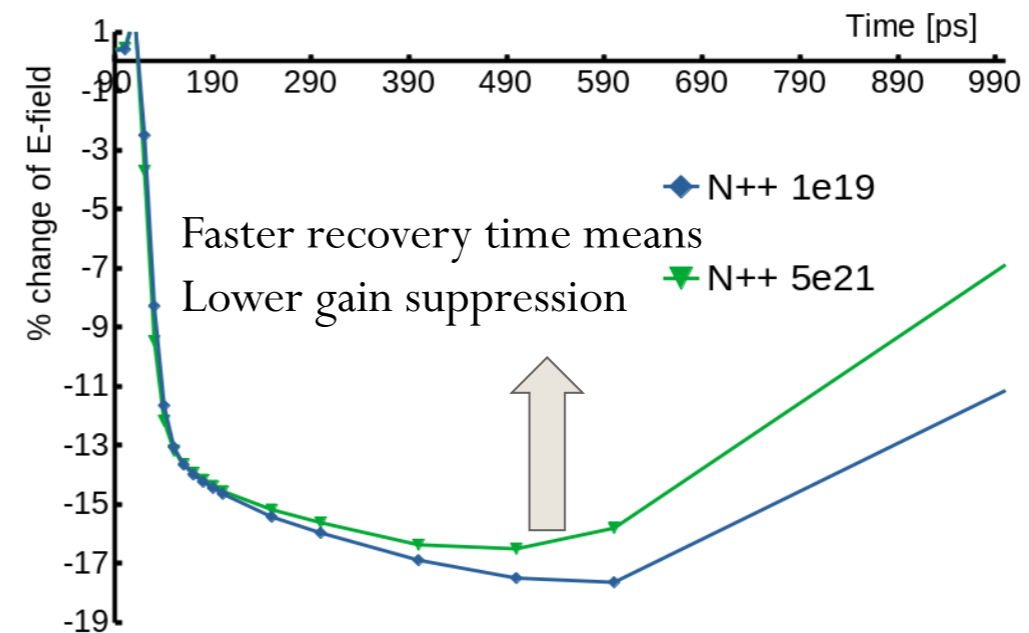
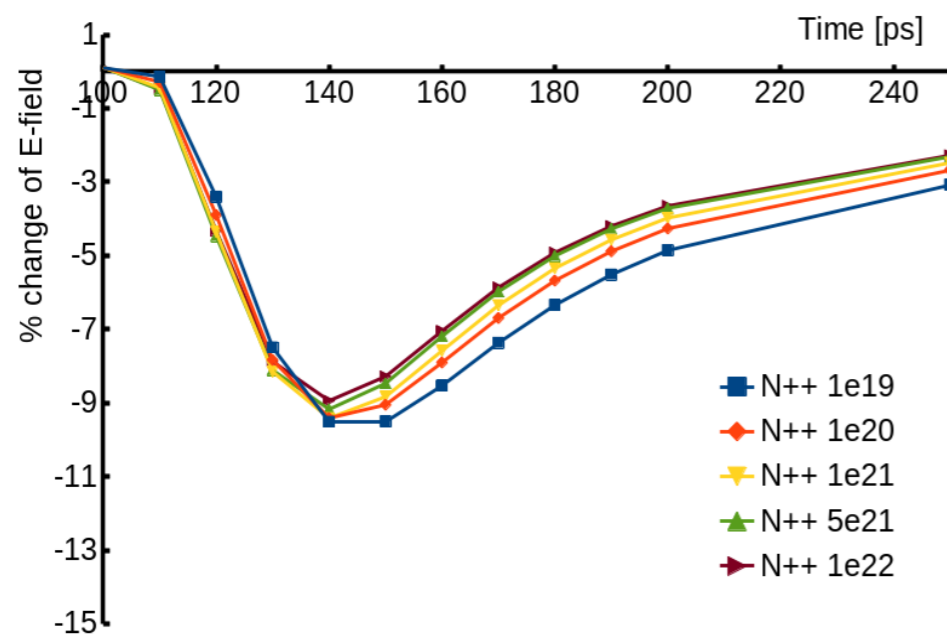



# Ion beam studies at CENPA tandem accelerator

- Study of the gain suppression effect at the CENPA tandem accelerator
- Injection of large amount of charge with low energy protons
  - 2 MeV and 3 MeV protons, deposited charge of 30-70 minimum ionizing particles (MIP) equivalent
- Data taken at different angles, PiN response change linearly with angle, LGAD gain suppression makes it non-linear
  - Between  $0^\circ$  and  $45^\circ$  there should be a  $\sqrt{2}$  factor. For LGADs is a factor  $>2$  because of increased gain suppression at  $0^\circ$
- (very preliminary, data taken last week)

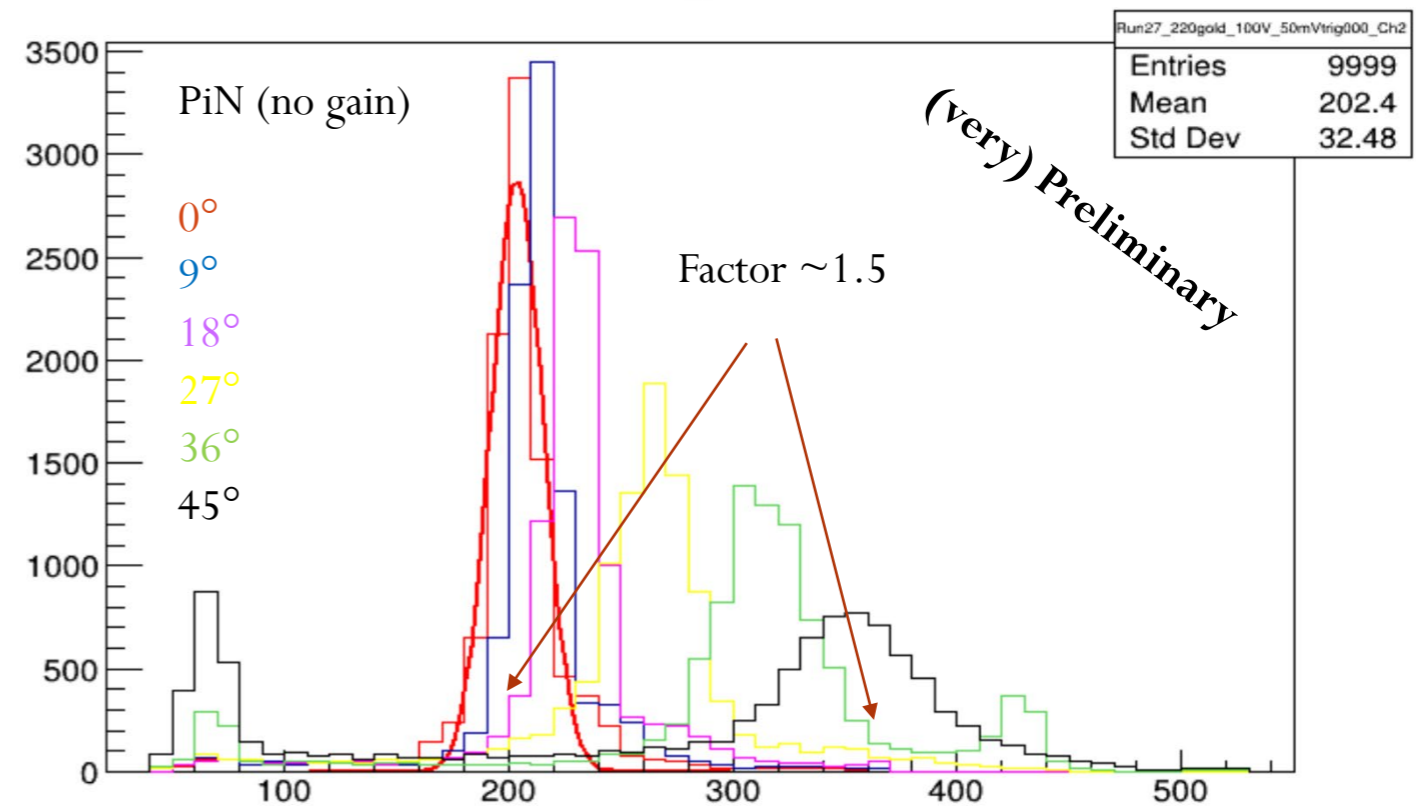
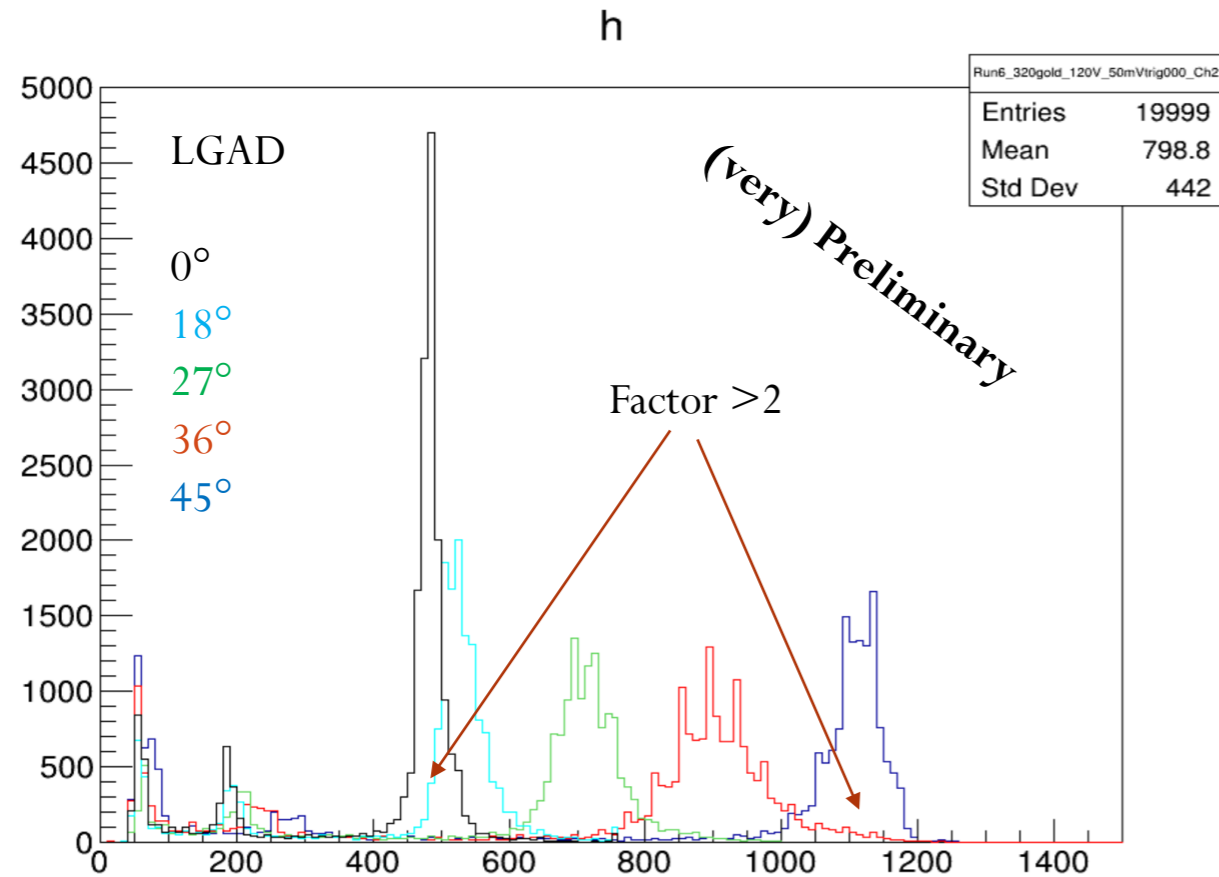
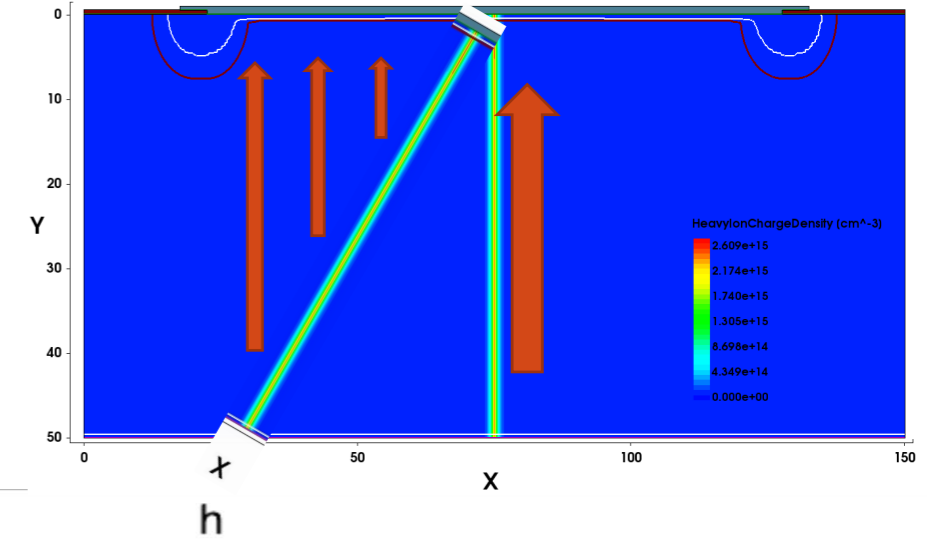

# Conclusions

---

# Conclusions

- **LGADs** are an interesting “new” technology
  - Fast pulses ( $\sim 1\text{ns}$ ), internal gain of 20-50, **exceptional time resolution**
- **Radiation hardness** proven up to **few  $1\text{E}15\text{ Neq}$** 
  - Push to reach  $1\text{E}16\text{ Neq}$  and beyond for future colliders
- **New technologies will allow dense LGAD pixelation**
  - TI-LGADs, iLGADs, AC-LGADs, DJ-LGADs
  - Maintain fast pulses ( $\sim 1\text{ns}$ ), internal gain of 20-50 and exceptional time resolution of LGADs but allow dense LGAD pixelation
- **AC-LGADs** are an innovative high density LGAD technology
  - Charge sharing mechanism reduces the channel count in low pileup environment
- **Future LGAD applications in many fields**
  - High energy physics (ATLAS/CMS)
  - Nuclear physics (ePIC, PIONEER)
  - Low energy X-ray detection
  - Fast beam monitoring
  - ... Medical science (TOF PET) ... space ...

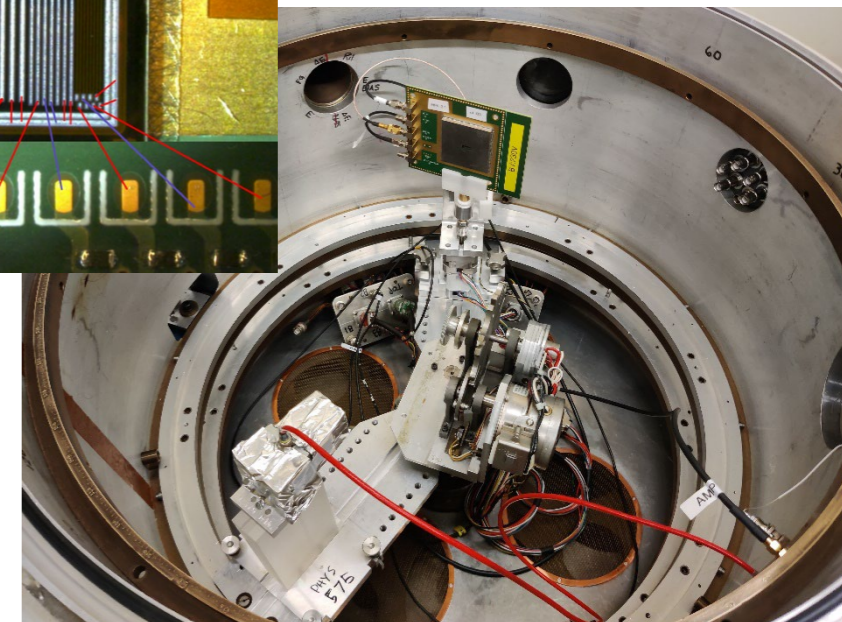
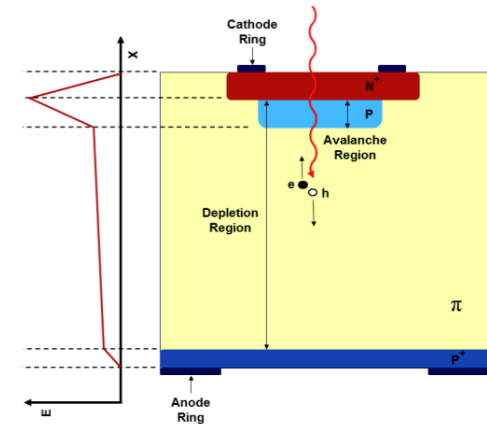
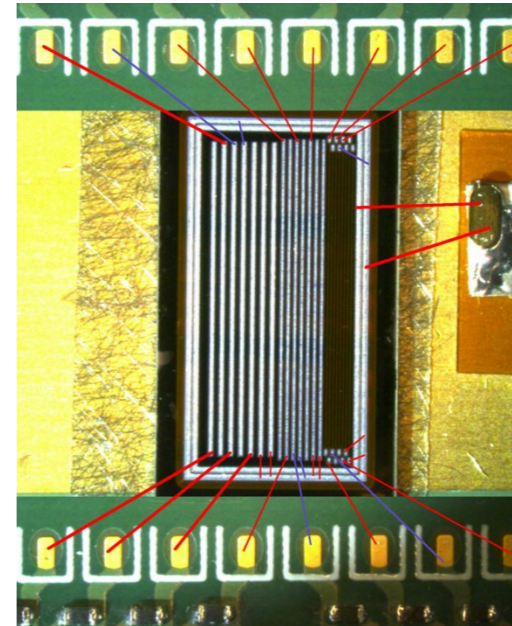



Thanks for the attention



**Many thanks to the SCIPP group students and technicians!**

Thanks to FBK, HPK, BNL to have provided sensors for this study

This work was supported by the United States Department of Energy,  
grant DE-FG02-04ER41286

This work was partially performed within the CERN RD50 collaboration.

Part of this work has been financed by the European Union's Horizon 2020 Research and Innovation funding program, under Grant Agreement no. 654168 (AIDA-2020) and Grant Agreement no. 669529 (ERC UFSD669529), and by the Italian Ministero degli Affari Esteri and INFN Gruppo V.

This work was supported by the United States Department of Energy, grant DE-FG02-04ER41286.  
CACTUS DJ-LGAD SBIR

Use of the Stanford Synchrotron Radiation Lightsource, SLAC National Accelerator Laboratory, is supported by the U.S. Department of Energy, Office of Science, Office of Basic Energy Sciences under Contract No. DE-AC02-76SF00515.

The group from USP acknowledges support from FAPESP (grant 2020/04867-2) and CAPES.

# (preliminary) charge sharing comparison

- Plot: charge sharing % after second neighbor for different sensors length and strip width but same pitch (500um)
- Charge sharing changes with strip pitch/width, strip length and bulk thickness
- Some preliminary conclusions
  - With larger strips there's less charge sharing
  - Charge sharing increases with strip length
  - Thicker sensors increase charge sharing

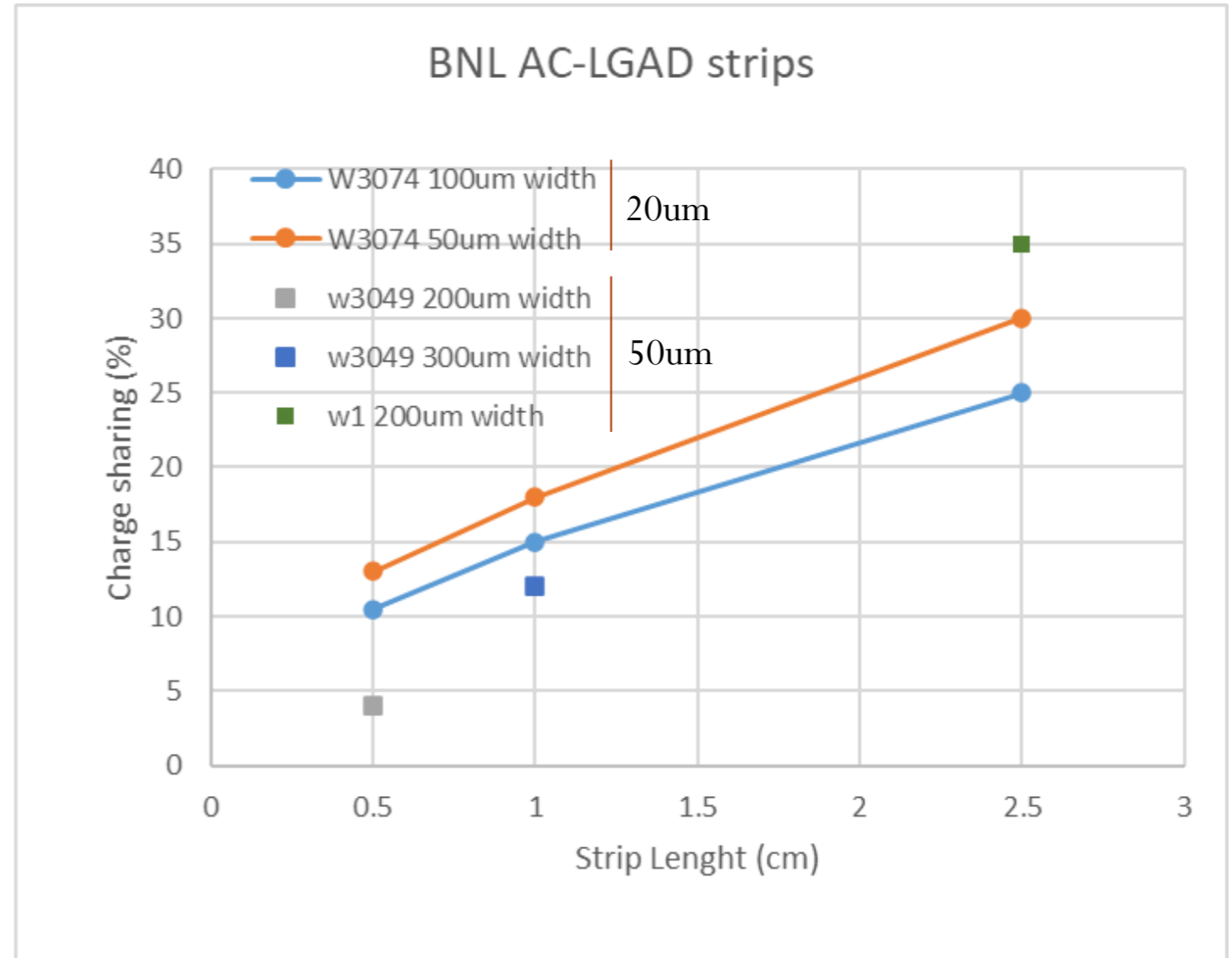

# Pulse shape for LGADs

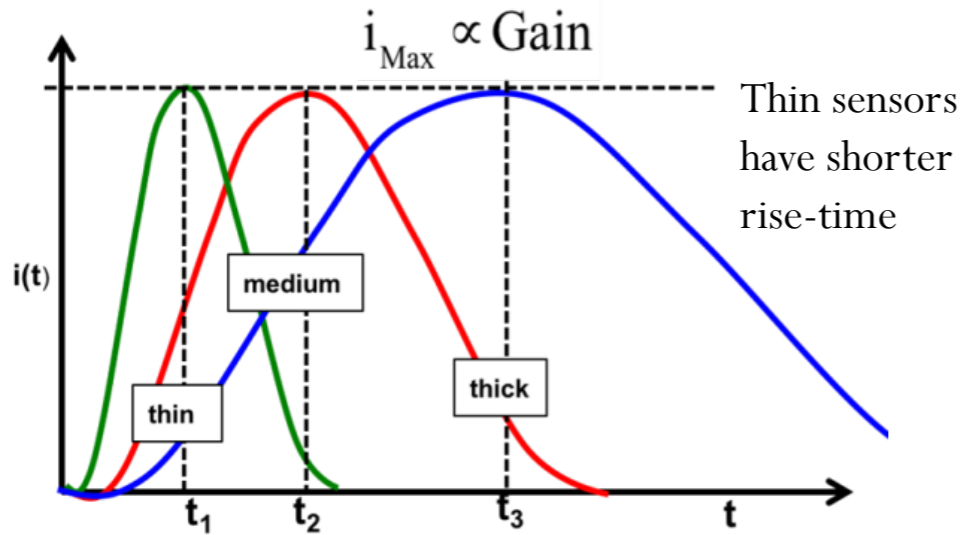

- Collected charge from MiP is proportional to thickness of a silicon detector
  - Thin detectors have low collected charge (50  $\mu\text{m} \rightarrow \sim 0.5 \text{ fC}$ )
- Thanks to gain LGADs can go thinner than normal silicon detectors
  - Down to 50  $\mu\text{m}$  and 20  $\mu\text{m}$ !
- **Thinner detectors have shorter rise time and less Landau fluctuations**
  - Furthermore, the full charge collection time is fast ( $\sim 1 \text{ ns}$ )
  - All with a **great signal to noise ratio**
- Better signal to noise ratio and thin detectors means improved timing resolution
  - **Time resolution down to 20 ps**

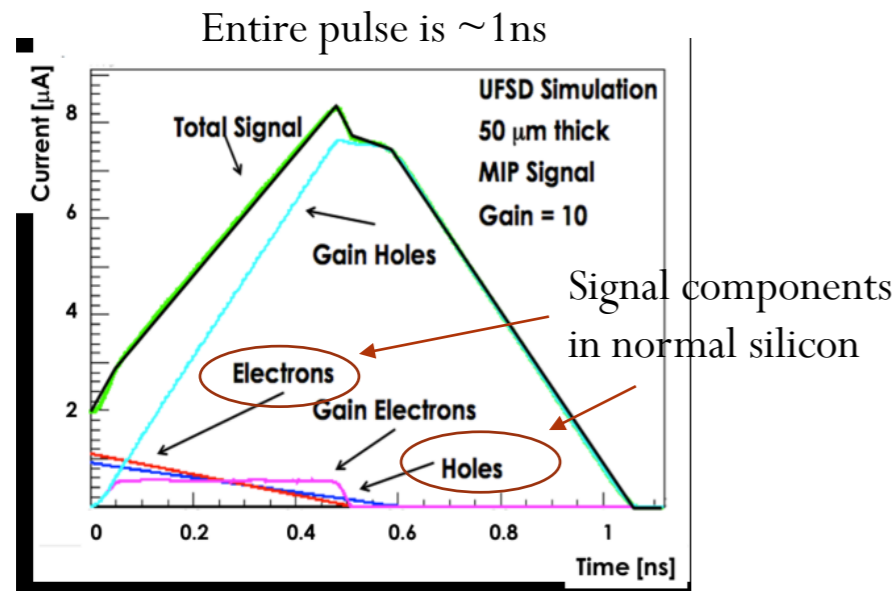

# Radiation damage model

- Radiation damage for LGADs can be parameterized
  - $N_A(\phi) = g_{eff}\phi + N_A(\phi=0)e^{-c\phi}$
- Acceptor creation:  $g_{eff}\phi$ 
  - By creation of deep traps
- Initial acceptor removal mechanism:  $N_A(\phi=0)e^{-c\phi}$ 
  - Reduction of doping concentration in the multiplication layer  $\rightarrow$  reduction of gain
  - **C-factor (acceptor removal constant) depending on detector type**

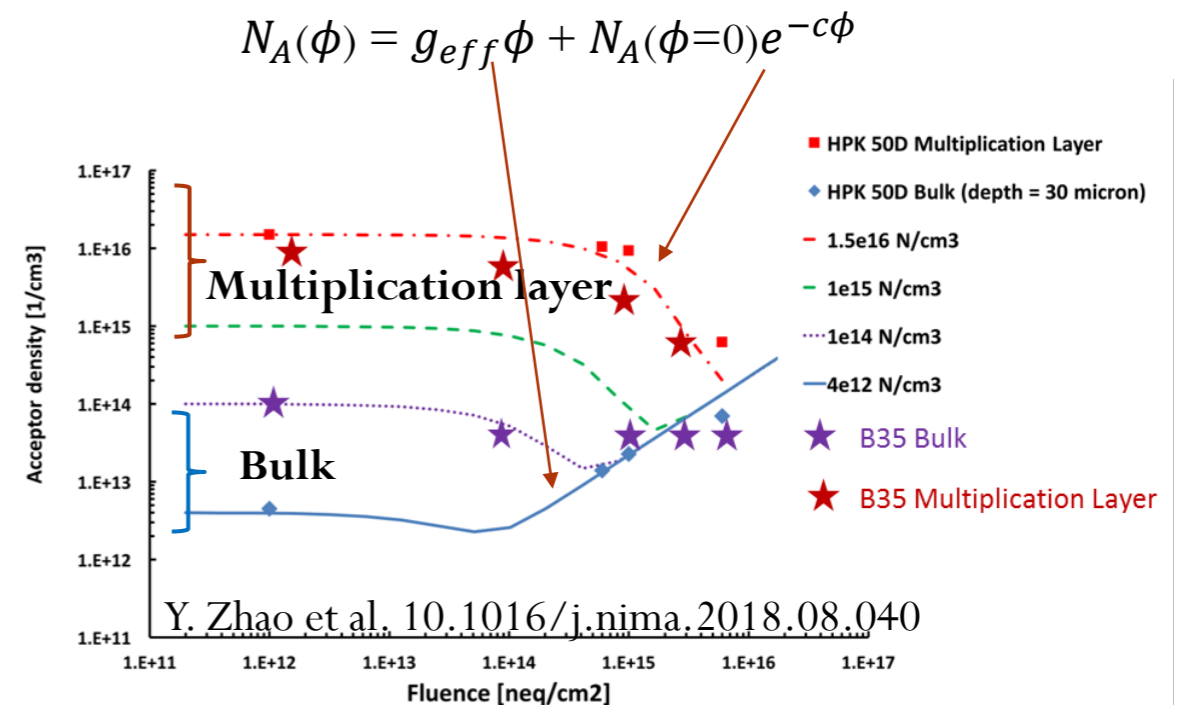
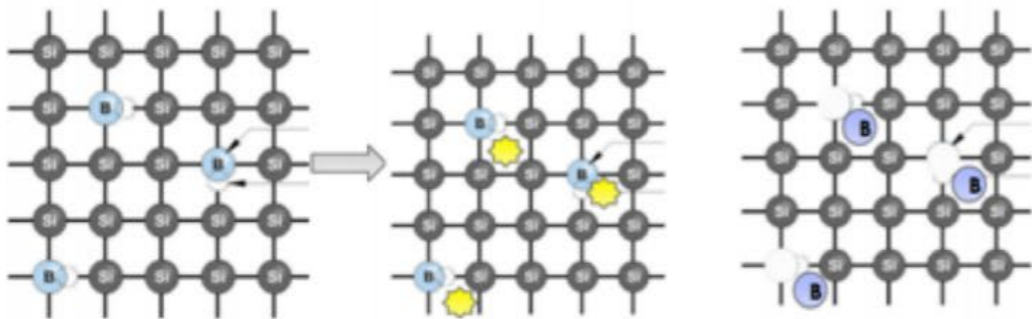

## Boron

Radiation creates interstitial defects that inactivate the Boron:  $Si_i + B_s \rightarrow Si_s + B_i$   
 $B_i$  might interact with Oxygen, creating a donor state



# AC-LGAD strips

- Since the signal is AC-coupled the signal goes down with distance
  - On a normal DC-coupled sensor there would be a constant signal
- The position of an event can be reconstructed by looking at the fraction in between the strips
  - E.g. when the signal is split 50-50 the event is exactly between strips
  - Next-neighbor can be used to refine reconstruction

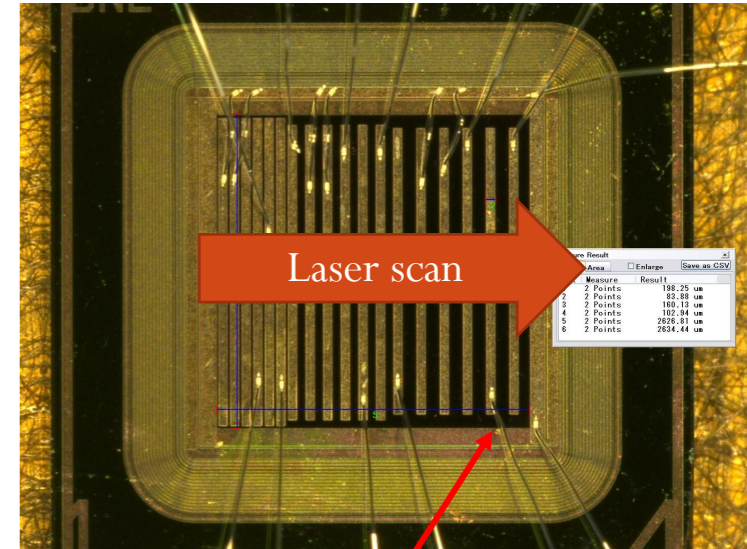

Example reconstruction by fraction on an FBK sensor

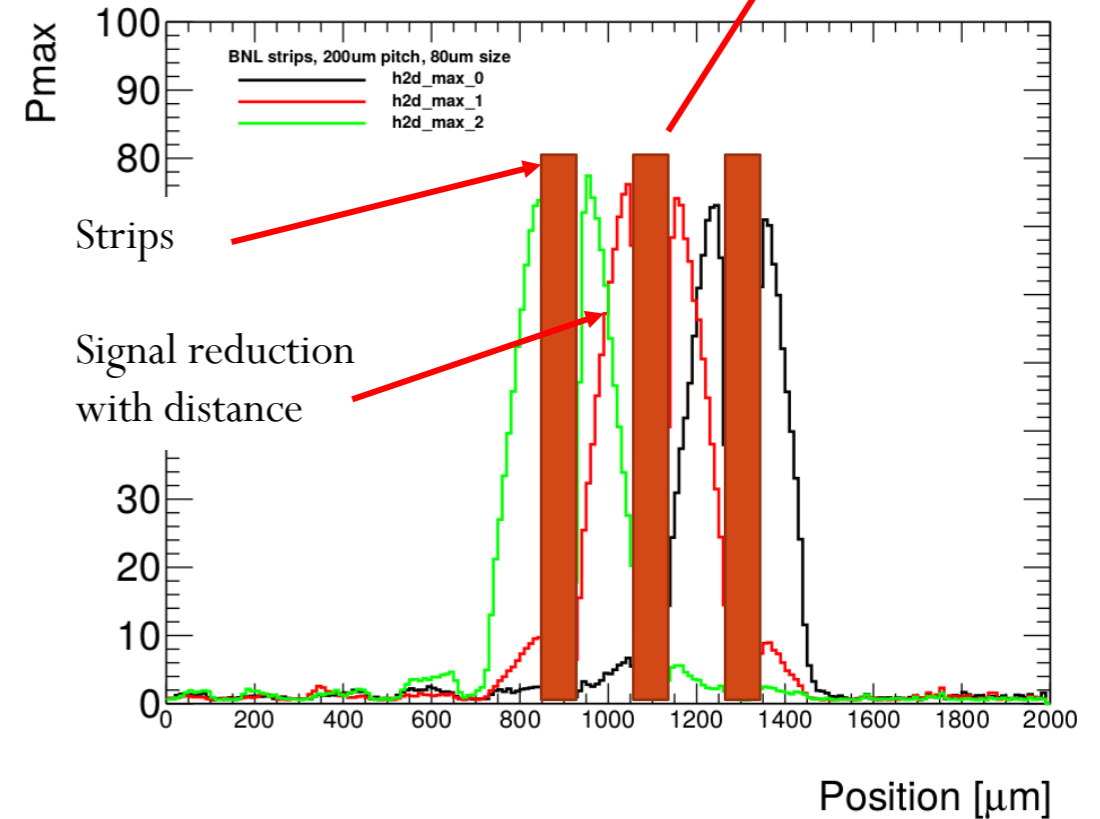
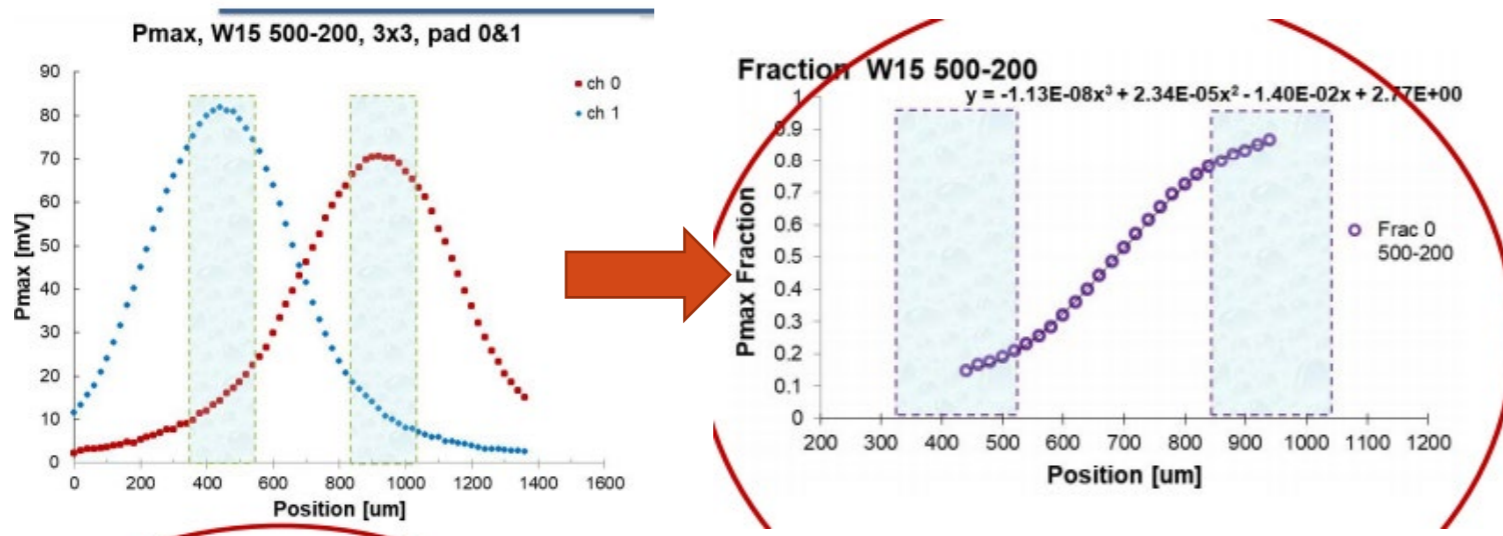

# Position reconstruction

- Simple fractional method works with strips
- **However for complicated geometries (hexagons, squares, etc) more than 2 channels are needed, fractions need to be calculated taking into account multiple pads**
- Master formula method for position reconstruction: Use signal fractions in between channels to reconstruct position

The fraction of signal seen in each pad is:

$$S_i(\alpha_i, d_i) = \frac{\frac{\alpha_i}{\ln(d_i)}}{\sum_1^n \frac{\alpha_j}{\ln(d_j)}}$$

where:

- $d_i$  = distance hit-pad
- $\alpha_i$  = angle of view hit-pad

## Important points:

- The signal seen in a pad depends upon how many other pads are nearby
- A signal can be seen by 2,3 or 4 pads, depending on the hit location

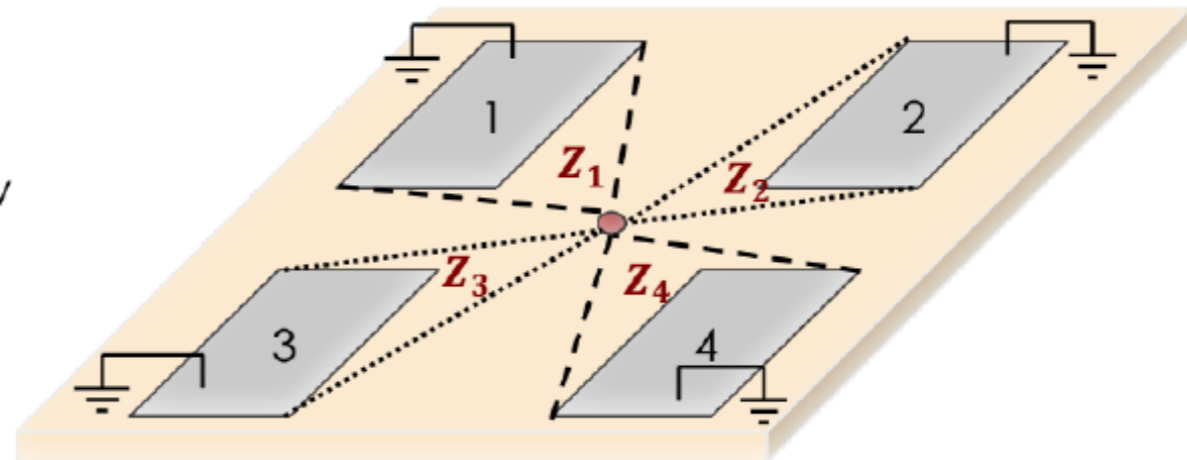
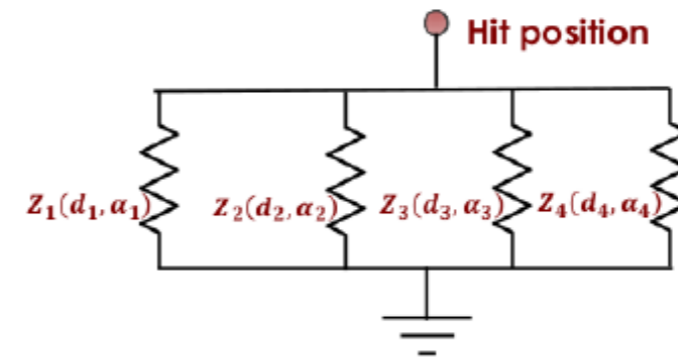

# AC-LGAD geometries

- With AC metal it is possible to create new geometries
  - Simple metal pattern on top, no underlying structures
- **FBK AC-LGAD metal etched at BNL to create non-conventional metal structures**
- Sensors with circular pads, crosses, micro-strips etc...
  - Simplify the position reconstruction process
  - If simple enough it can be done on-chip
  - Achieve needed X-Y position resolution (might have different requirements) vs channel density
- E.g.: Cross have separated boxes were reconstruction can be done with fractions from one cross to the next in X/Y
  - Fraction can also be decoupled in X and Y

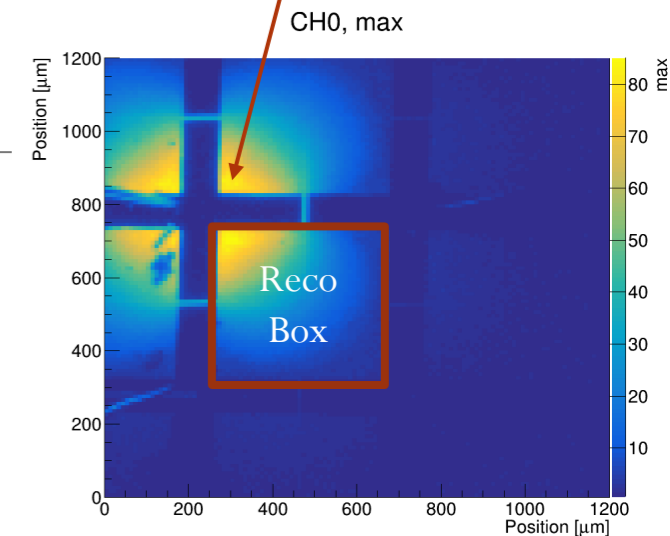
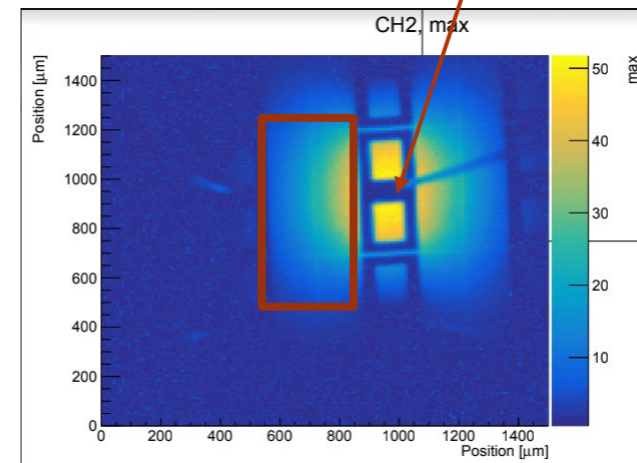
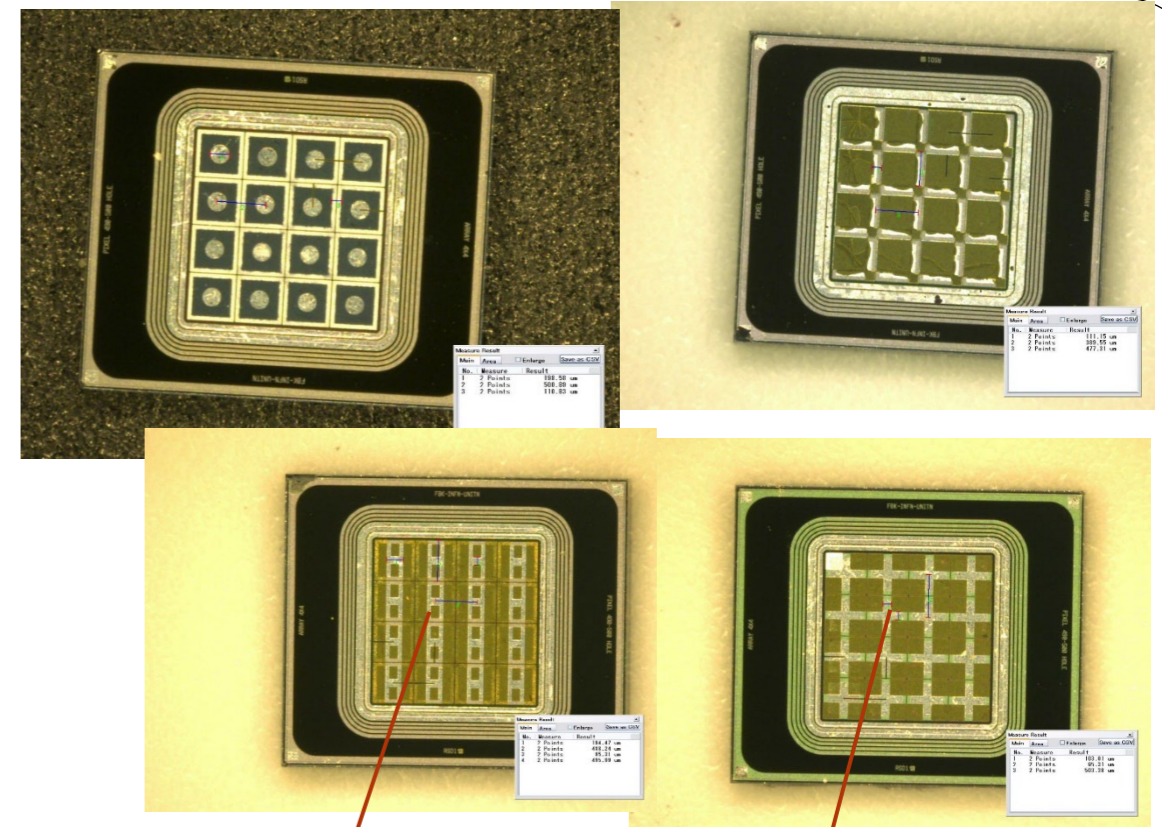

# AC-LGAD strips

- Testing of **AC-LGAD prototype strip sensors** (50  $\mu\text{m}$  thick) with several geometries
  - Sensors produced at BNL for the EIC
- Same strip length and width, different pitches
  - Finer strips show a slightly better resolution, but higher channel count
  - Hit position resolution in direction perpendicular to the strip 5-15  $\mu\text{m}$
  - Study made with FNAL TB data
- Same geometry but with different lengths (study made with focused IR laser TCT)
  - Sensors with longer strips show increased charge sharing profile
  - Effect to be understood with simulation
- For **PIONEER 2 cm long strips with substrate thickness of 120 $\mu\text{m}$** 
  - **Best behavior:** charge shared only between two strips to have largest S/N
  - TCAD Simulation to study the charge sharing

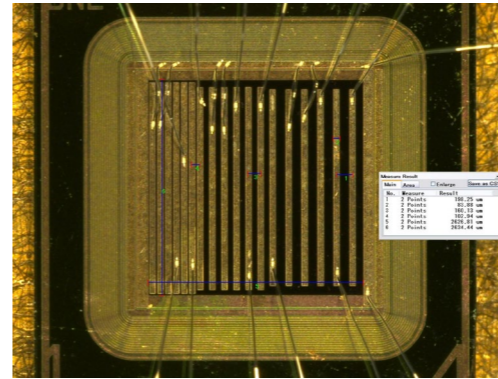

Position resolution vs position for AC-LGAD strips of different pitch

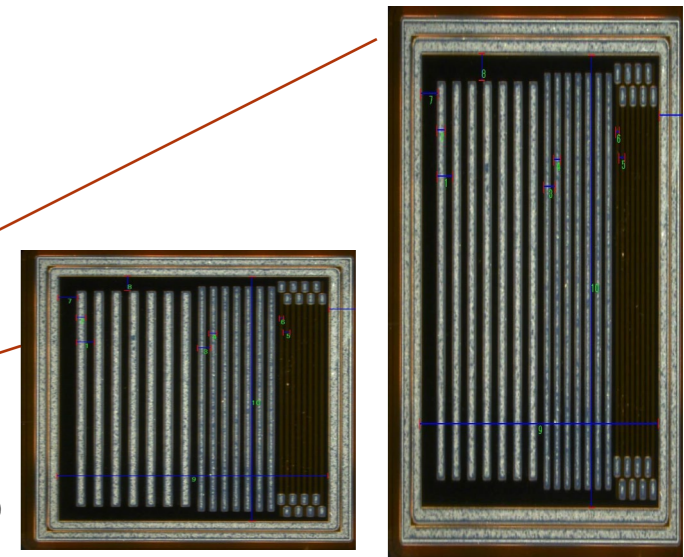
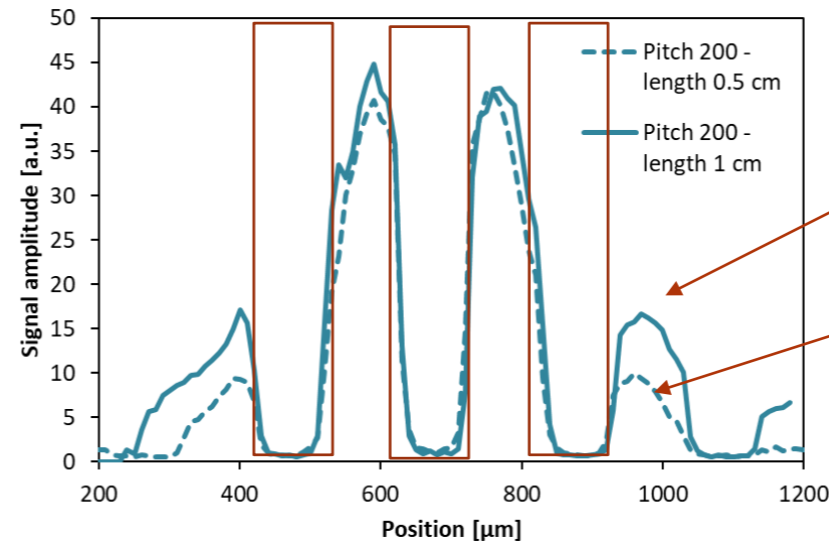
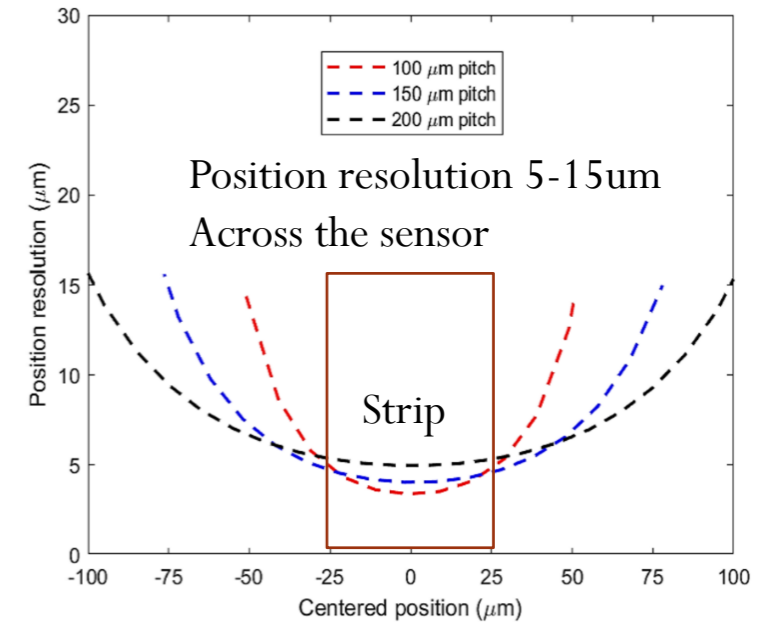

# Alpha particle

- Gain suppression studied with **alpha particles**
  - Deposition of  $\sim 100$  MiP
  - Studied in a vacuum chamber to reduce energy spread
- High gain suppression observed for high gain sensor
  - **Several types of gain layer design under study**
- The effect is expected to change with angle of incidence
  - What matters is the local charge concentration in the gain layer, so the “projection” of the track to the gain layer
- **Compare the suppression with alpha particles with simulation**

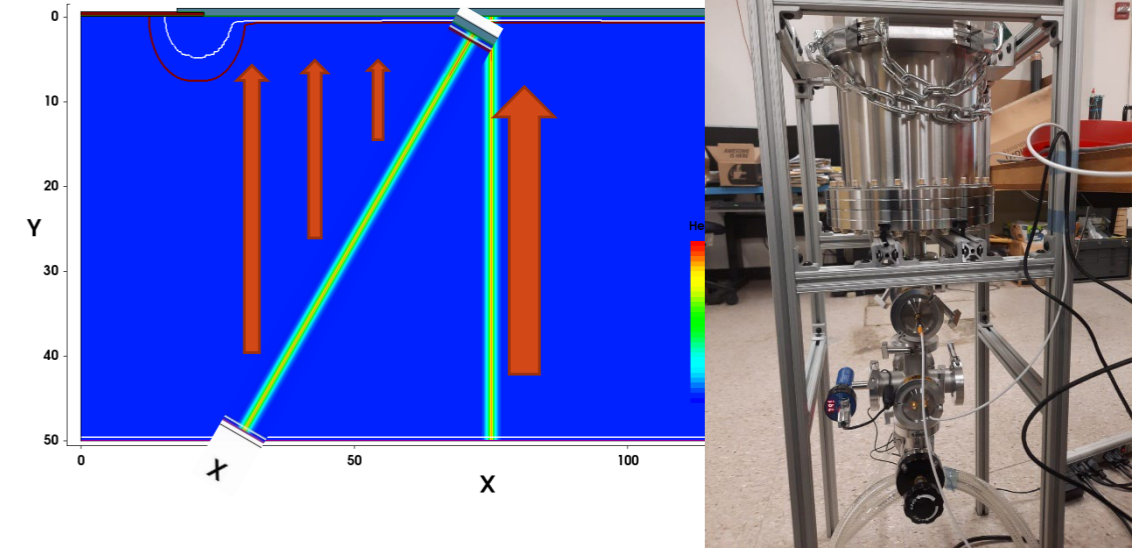

Gain suppression observed with alpha particles

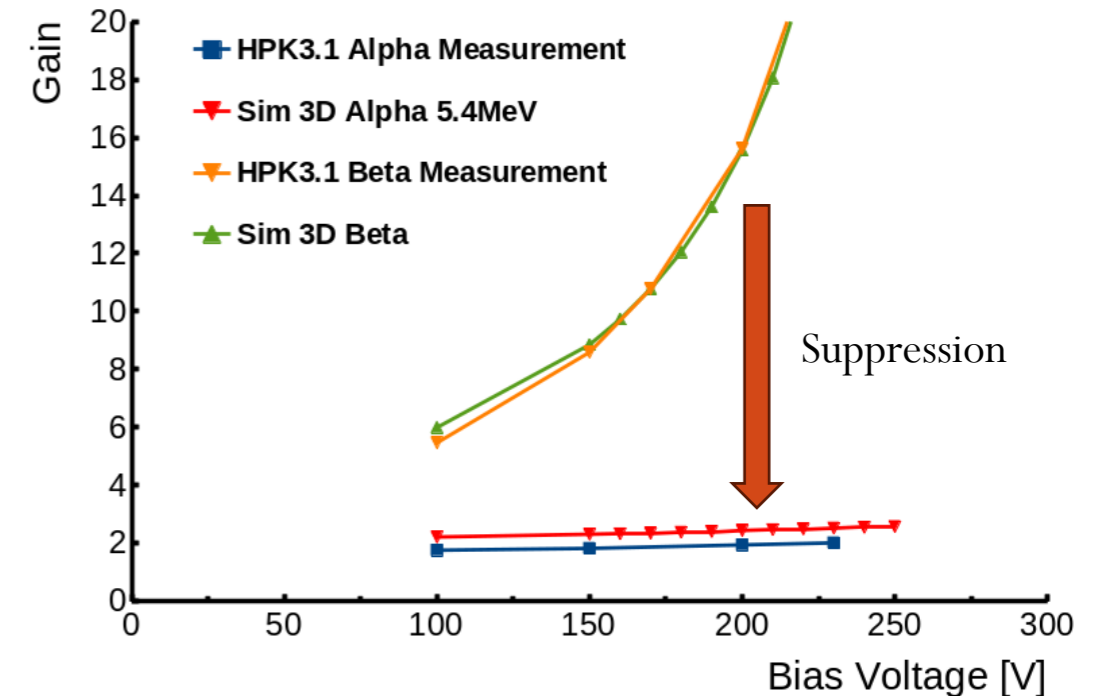

# AC-LGAD device simulation

- **TCAD simulations to study AC-LGAD parameters variations**
  - Studies done with TCAD Silvaco and Sentaurus
- Study the effect of the N<sup>+</sup> doping concentration to the charge sharing profile
  - **More resistive N<sup>+</sup> reduce the charge sharing**
- Investigate strip geometry (pitch, length, width) effect on charge sharing
  - **Longer strip increase the charge sharing**
- Sensors studied are 50um thick, simulation is crucial to understand the behavior of 120um thick sensors for the baseline design
  - **Thicker sensors have a broader charge sharing profile**
- For most simulations TCAD in 3D mode is necessary to have realistic results

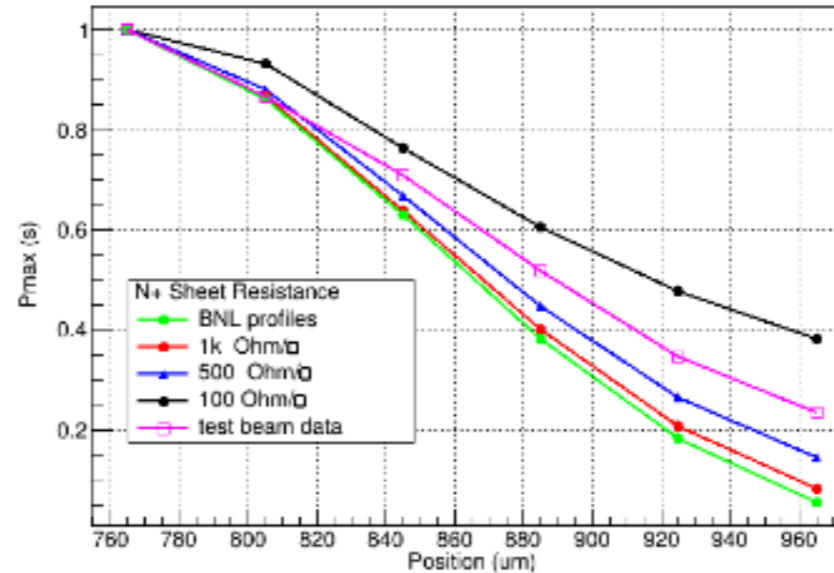

TCAD Silvaco simulation of charge sharing profile for different N<sup>+</sup> resistivity

TCAD Sentaurus 3D simulation of charge sharing profile for different strip lengths and sensor thicknesses

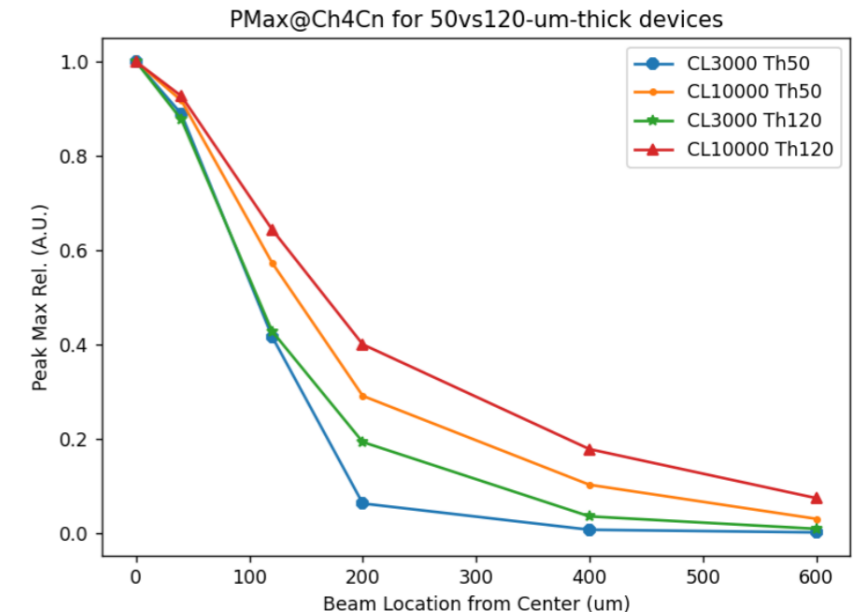

# Very thin LGAD sensors future uses

- **Very thin 20 um prototype LGAD**
- Possible improvements down to 15ps of time resolution
- Compared with 50um sensors (30-35 ps reach) and 30um sensors (25ps reach)
  - <https://arxiv.org/abs/2006.04241>
- However, new productions of 20 um devices from BNL, HPK and FBK still at 20ps level
- **Proper design is needed to surpass 20ps of resolution**
  
- **Very thin sensors** are also be candidates **for extreme radiation environments**
  - After substantial radiation damage thick detectors requires 1000s of V for depletion (Even though there is evidence of Charge trapping saturation)
- But a 50um sensor at  $1E17\text{Neq}$  is fully depleted at 500V
- Gain helps in having sufficient collected charge
- Can be operated in extreme radiation environment
- e.g. for vertex detection very close to the beam line in colliders
  - <https://doi.org/10.1016/j.nima.2020.164383>
  - <https://agenda.hep.wisc.edu/event/1391/session/12/contribution/60>

G30 sensor

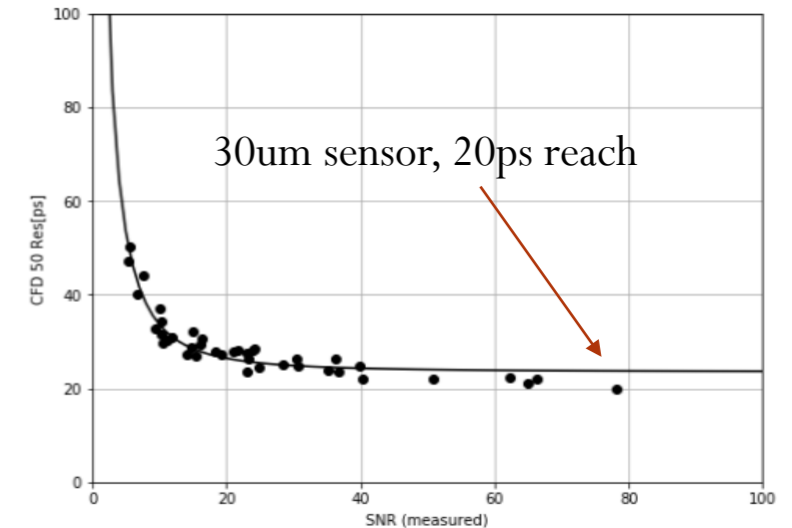

H20 Sensors

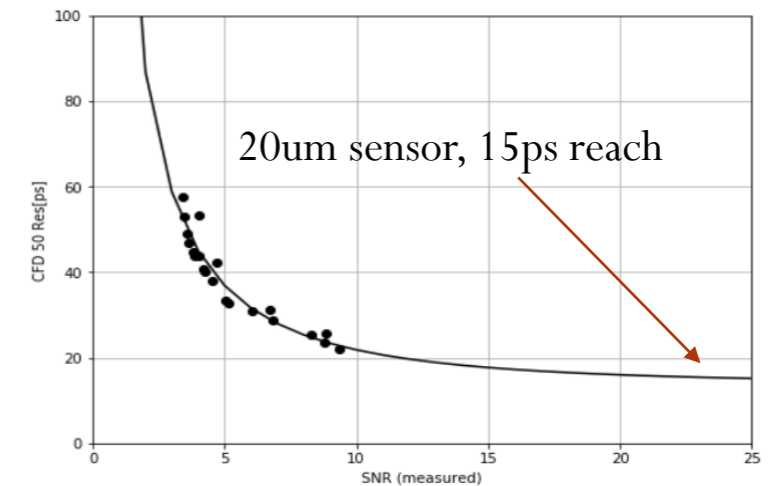

# Sensor testing – probe station, charge collection

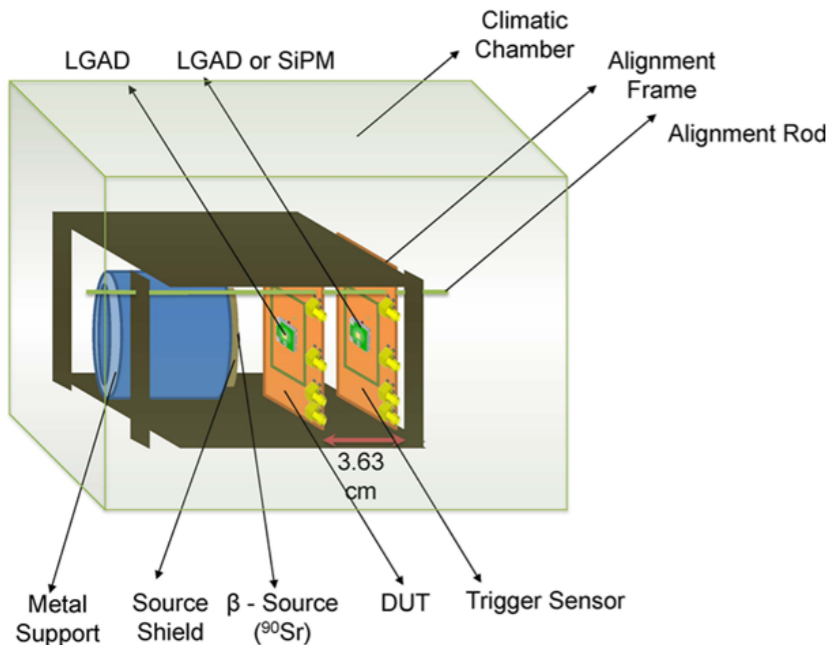
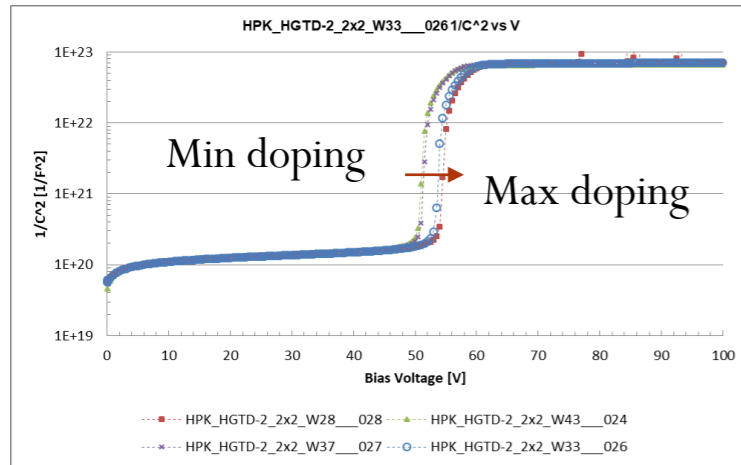

- **Probe station electrical testing**
  - Current of voltage (IV) and Capacitance over voltage (CV)
  - CV is used to probe the doping profile of the gain layer
- **Laboratory charge collection**
  - Using MiP electrons from a Sr90  $\beta$ -source ( $\beta$ -telescope)
    - Signal shape, noise, **collected charge**, gain, **time resolution**
  - Using Alpha source in vacuum (Am237),  $\sim 100$  MiPs deposition
  - Using X-ray gun
- **Laser TCT studies**
  - IR laser mimics a MiP response and allows charge injection as a function of position
  - Particularly useful to test arrays and AC-LGADs (see later)
- **Test beam at facilities (CERN, DESY, FNAL)**
  - Allows the study of MiP response with position information through an external tracker