

SRF Development at TRIUMF

Philipp Kolb

RF/SRF Group

Science Week, Jul. 31, 2023

2023-08-01

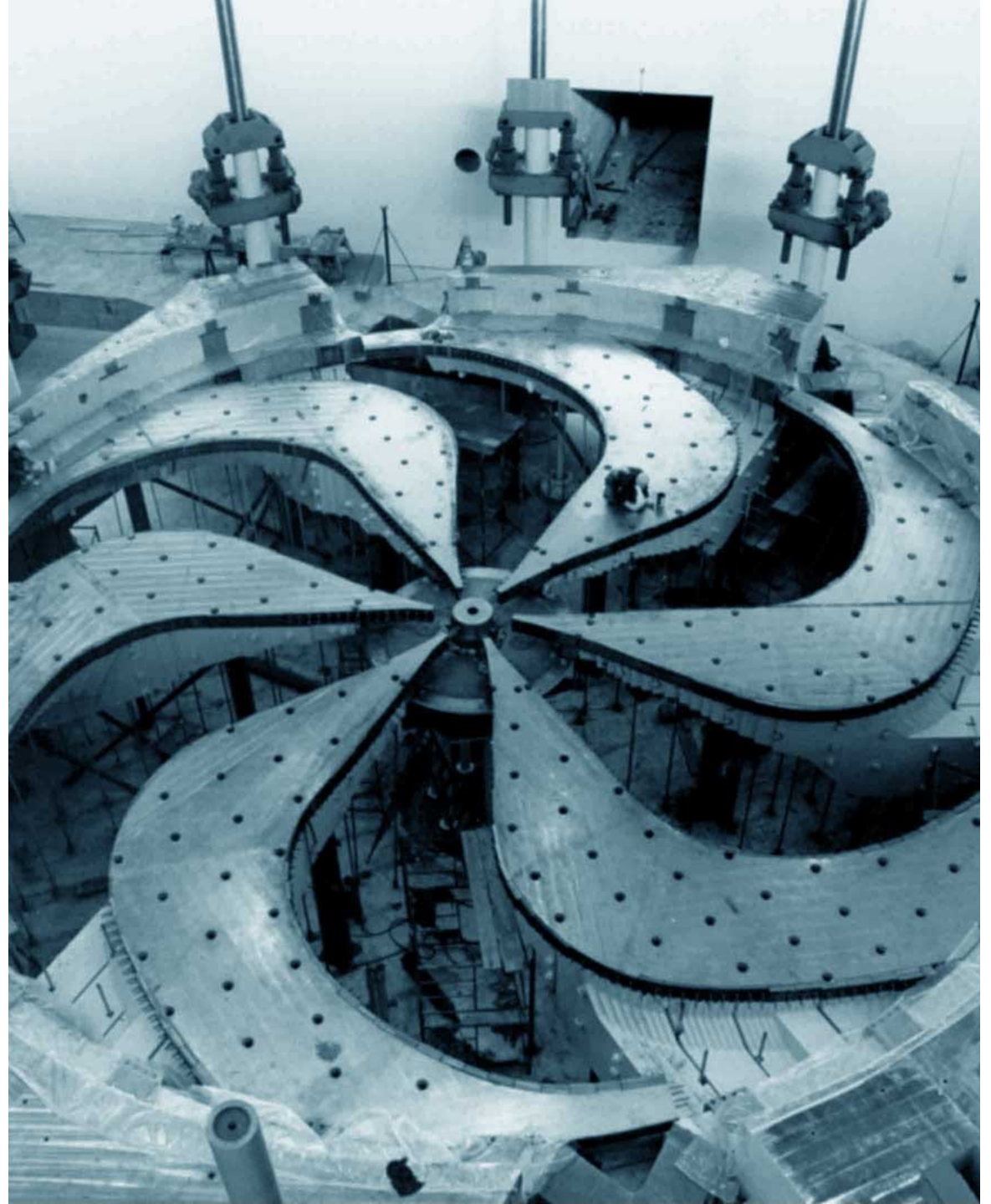

- SRF Overview
 - ISAC-II
 - ARIEL eLINAC
- Research
 - Coax. Cavities
 - SRF Materials
- SRF collaborations
 - VECC
 - Hi-Lumi LHC Crab Cavity Module
- Future
 - ISAC-II: Beyond 40MV
 - eLINAC: reliable 30MeV
 - EIC Crab Cavity

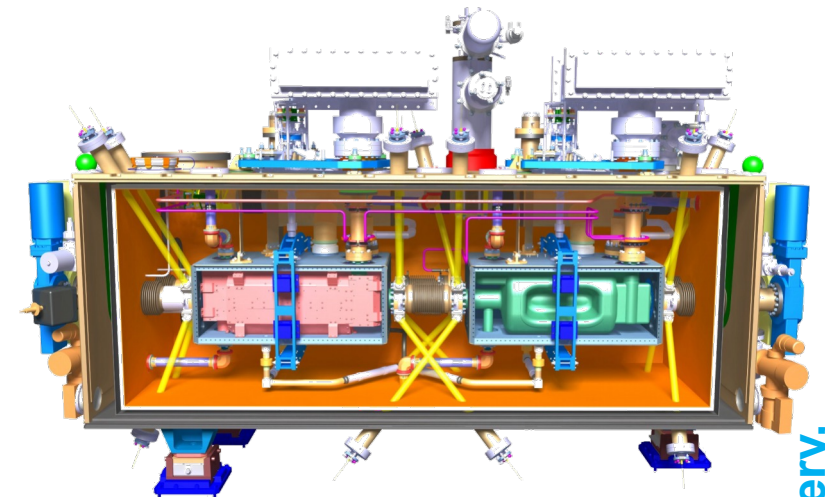
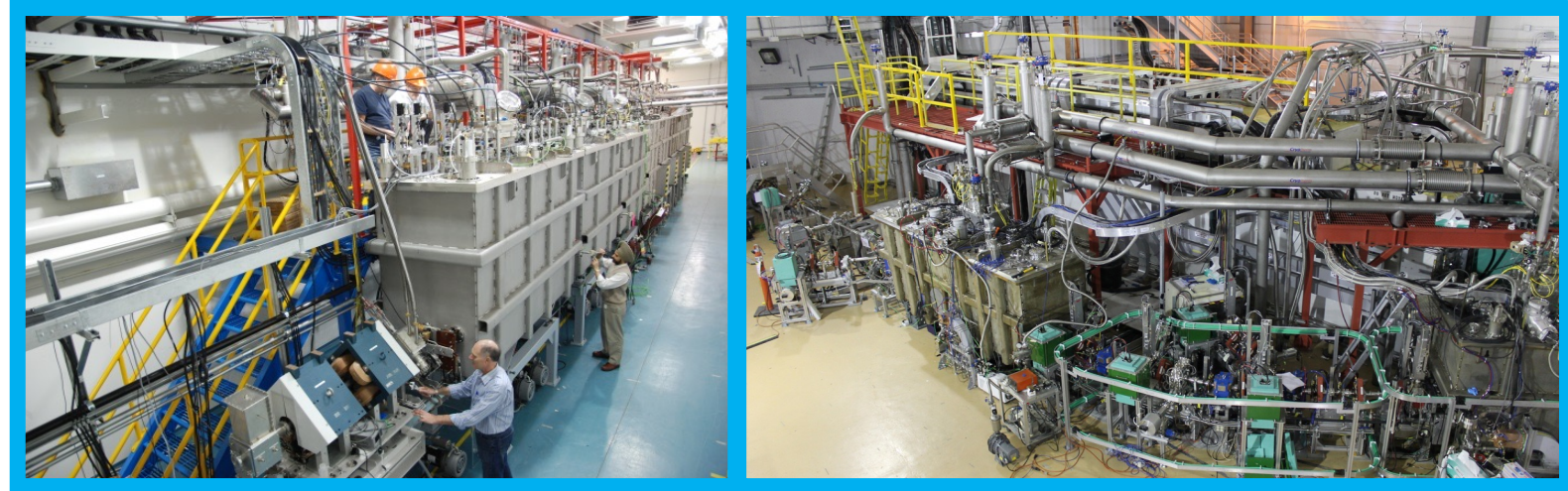

30MV 1.3GHz electron Linac

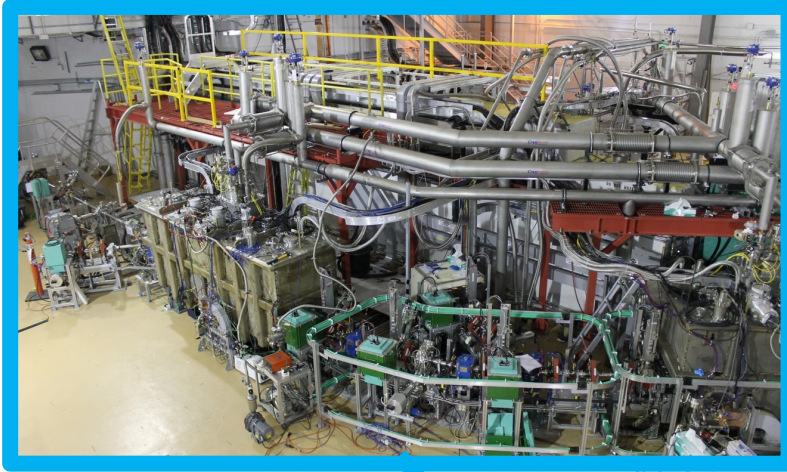

40MV Heavy Ion Linac

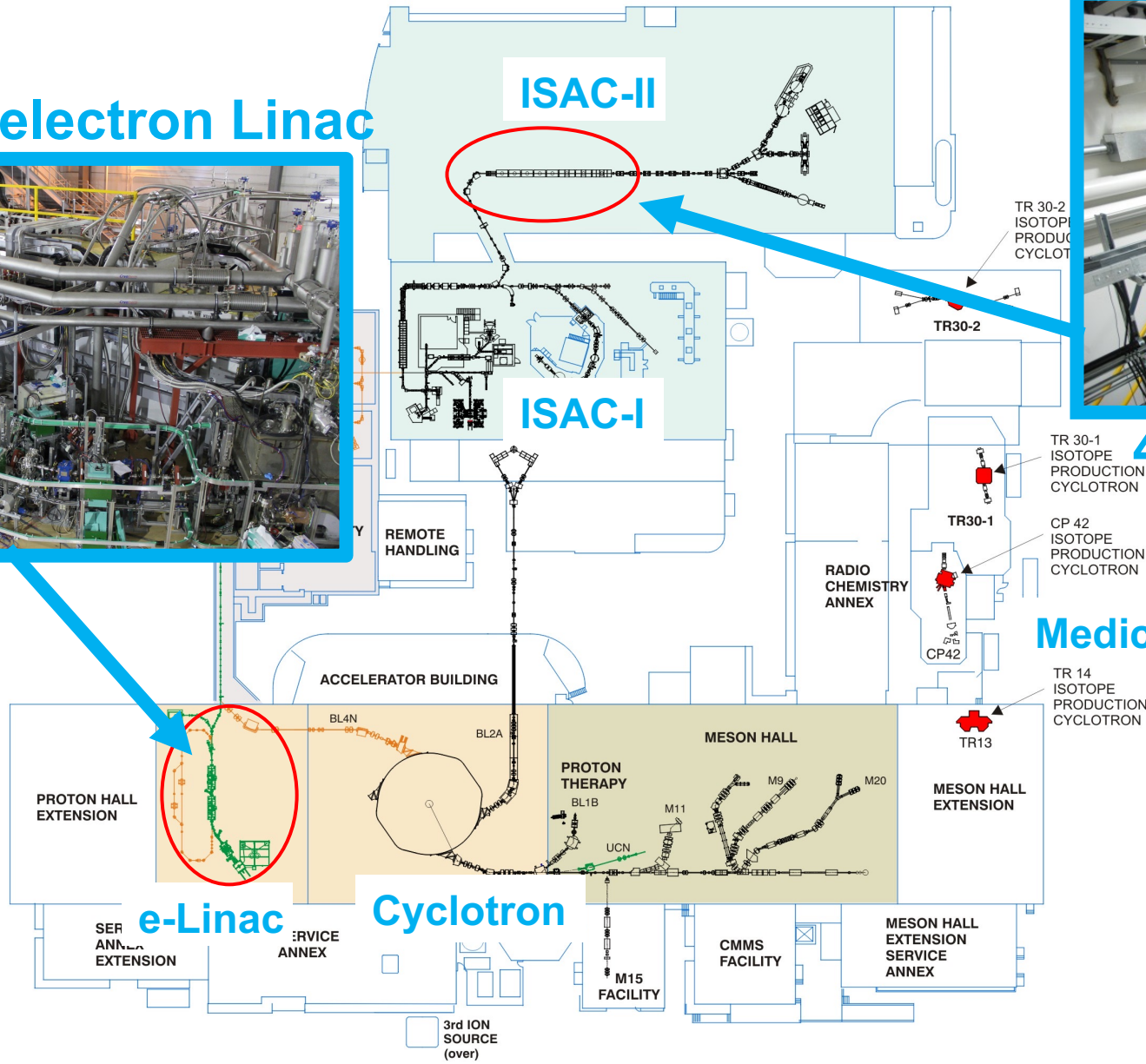

Medical Cyclotrons

ISAC-II Superconducting Linac

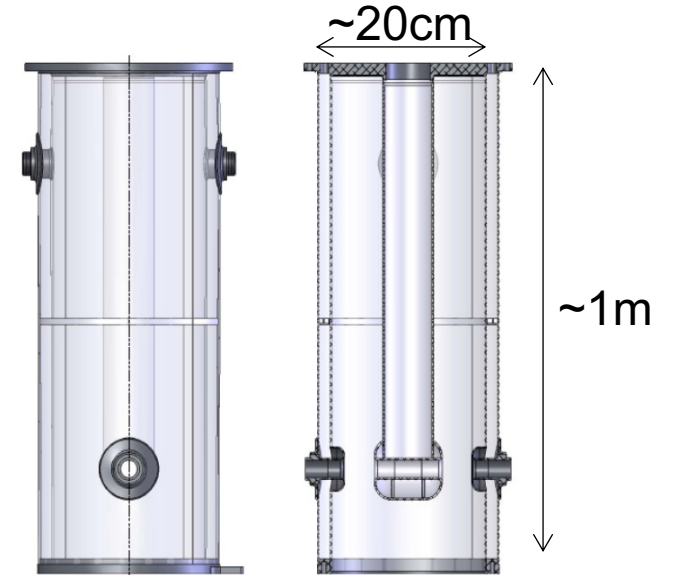
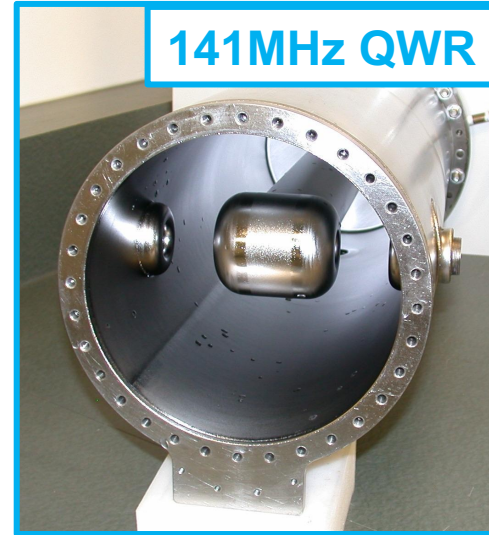
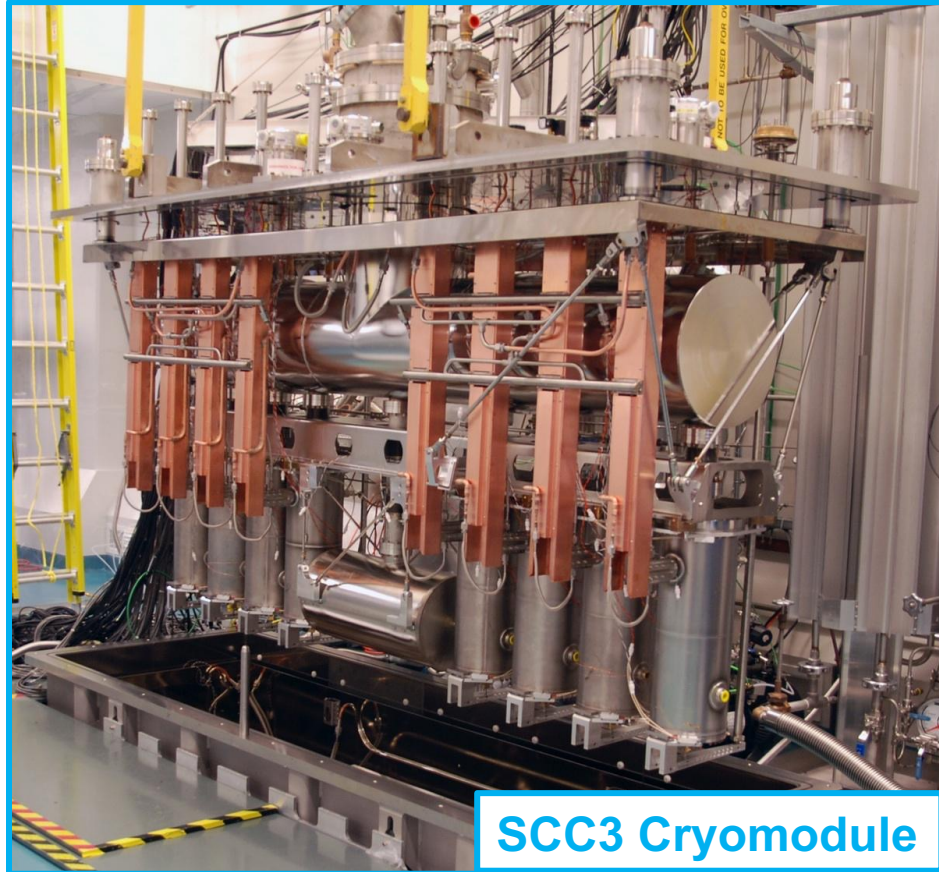

- 40MV SC Linac with 40 106/141MHz Quarter-Wave Resonators (QWRs), operating at 4.2K
- To accelerate Radioactive Ion Beams (RIB)
- Each cavity provides ~1MV of accelerating voltage
- In operation since 2006 – first 20 cavities
- Full 40 cavities installed in 2010
- ~2300 hrs / year operation
- Ongoing upgrade/maintenance program to maintain reliability

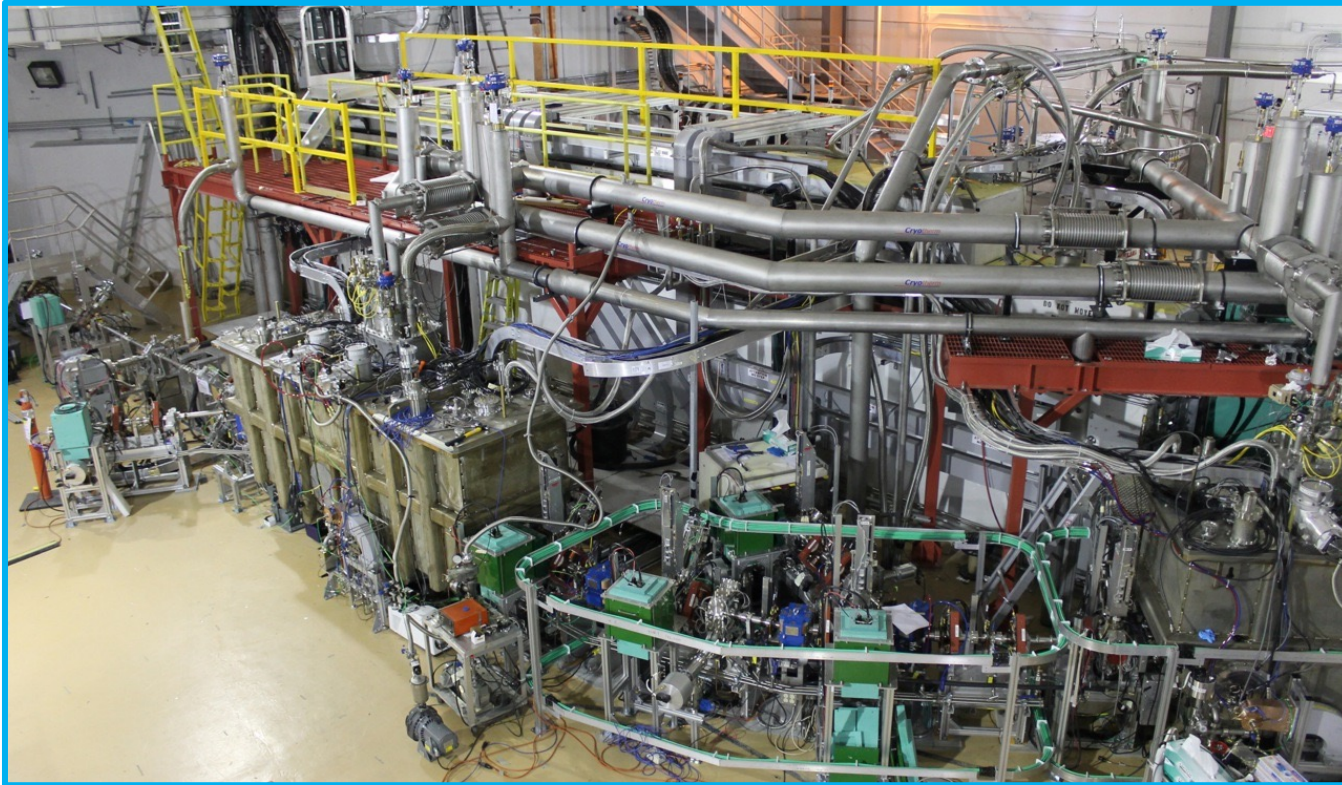

30MV 1.3GHz electron Linac

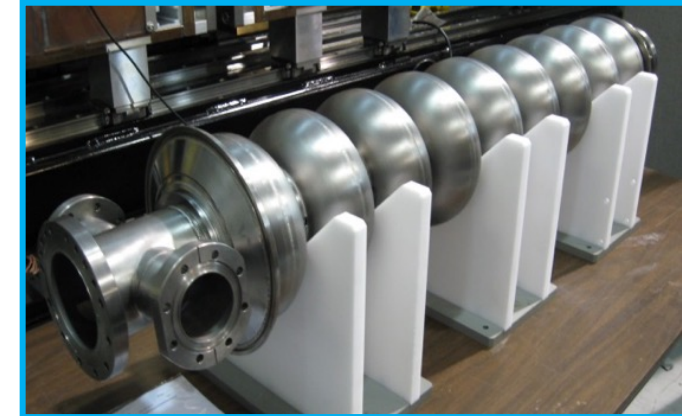

1.3GHz elliptical 9cell cavity

- Based on 1.3GHz technology used in XFEL / LCLS-II / ILC
- Driver Linac for photo-fission to produce RIB
- Operation at 2K
- 3 cavities, each providing 10MV
- High beam power – currently up to 10kW but capable of more
- Transitioning currently from Commissioning to Operation

Research & Student Programs

Using the strengths and unique capabilities of TRIUMF to fill research voids and covering niche research topics with high impact

- Coaxial cavities studies
- Material science for next generation of SRF materials

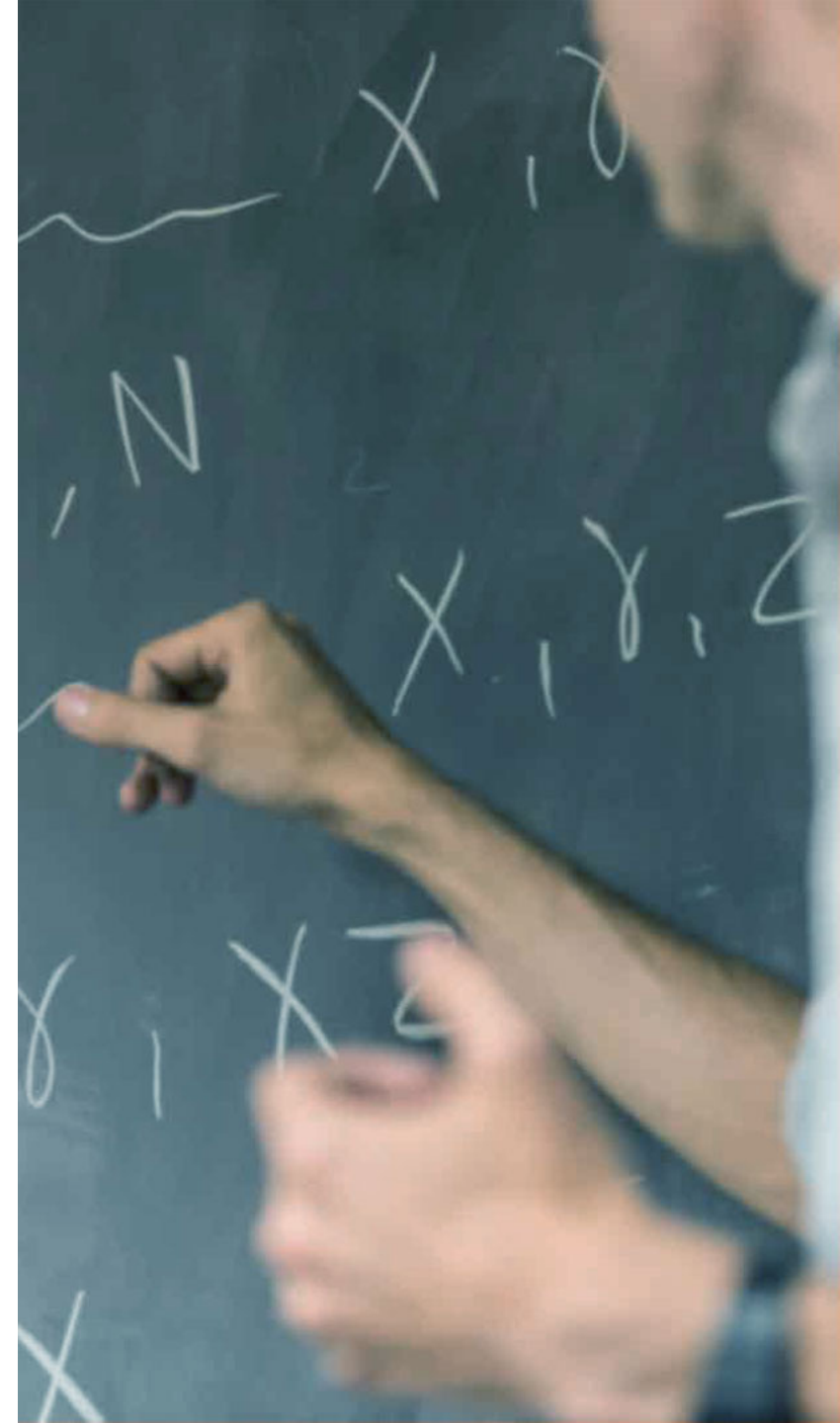

- Multi-mode cavities allow frequency resolved measurement of cavity performance without changing cavities
- Exploring how surface treatments impact performance – informs ISAC-II cavity retreatment, but also fundamental SRF interest
- Niche, but important research for SRF community

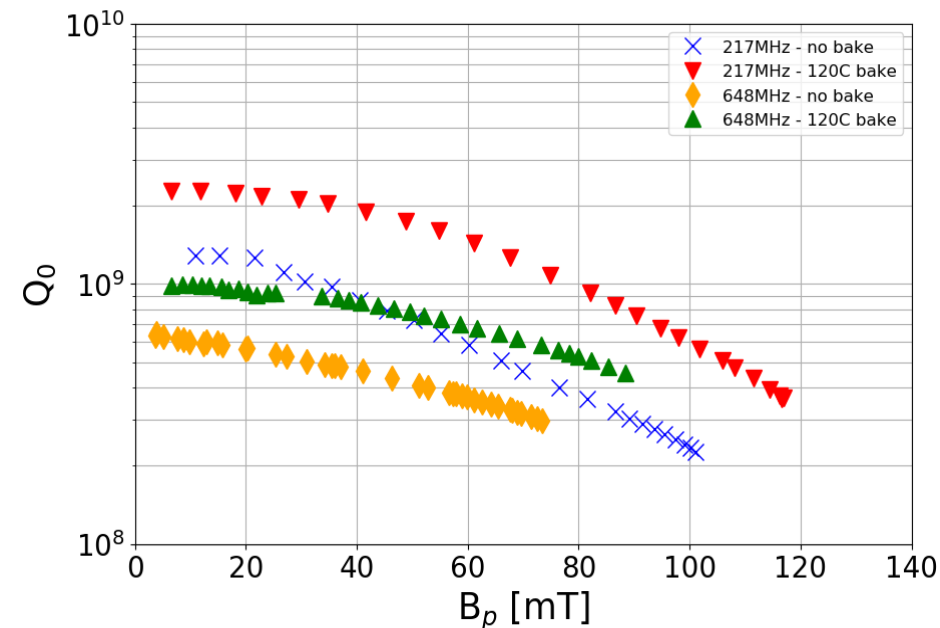
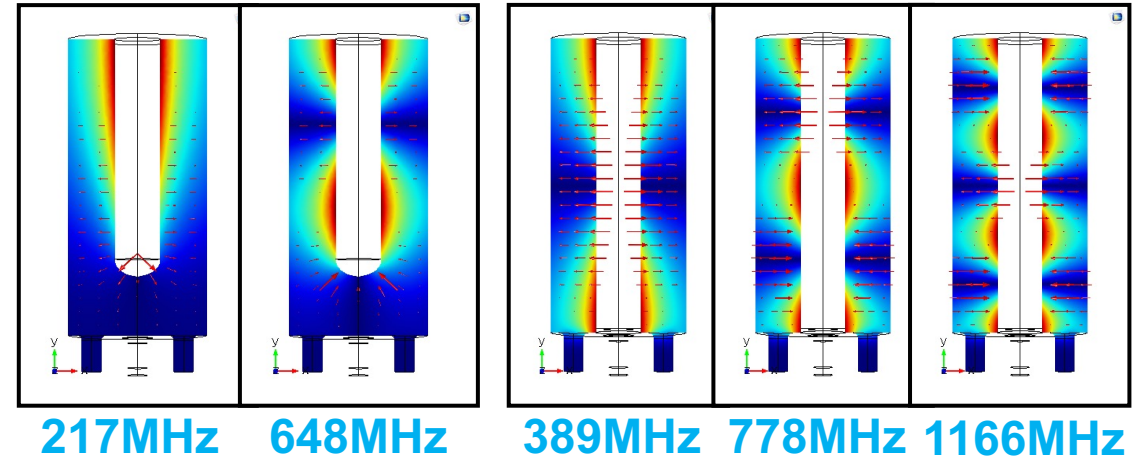
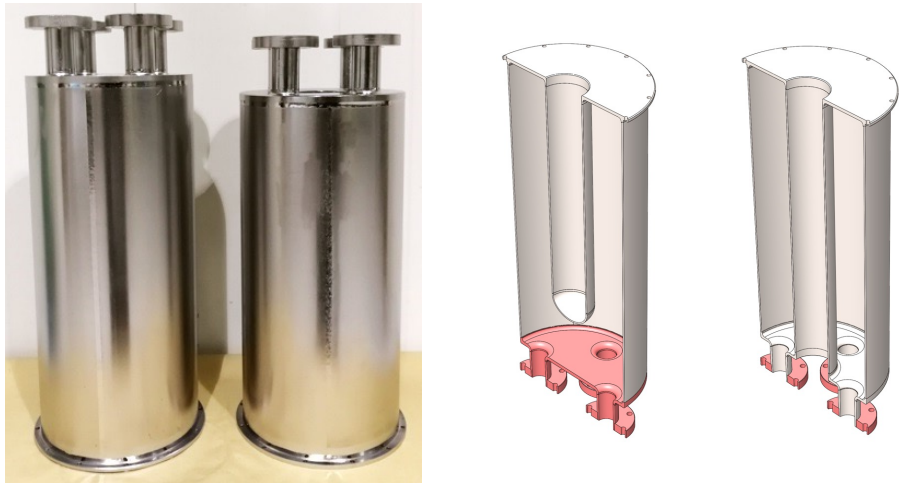

PHYSICAL REVIEW ACCELERATORS AND BEAMS 23, 122001 (2020)

Editors' Suggestion

Coaxial multimode cavities for fundamental superconducting rf research in an unprecedented parameter space

P. Kolb^{1,*}, Z. Yao¹, T. Junginger^{1,2}, B. Dury³, A. Fothergill³, M. Vanderbanck³ and R. E. Laxdal¹

* Follow-up paper in peer review

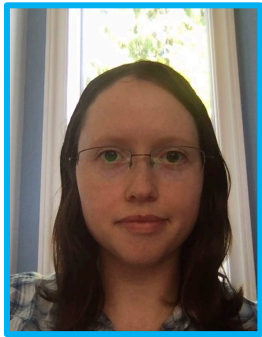

Magnetic Flux Expulsion Studies on Coaxial Resonators Ruth Gregory (MSc, UVic)

External magnetic flux can negatively impact cavity performance.

Question: How does cavity shape, cavity frequency, field direction and cooldown speed impact flux trapping and performance?

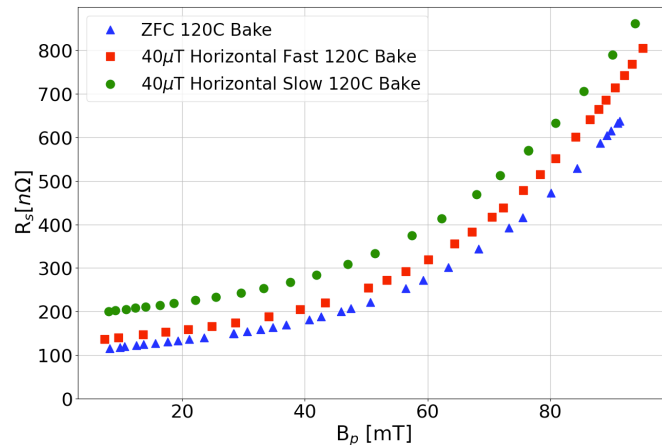
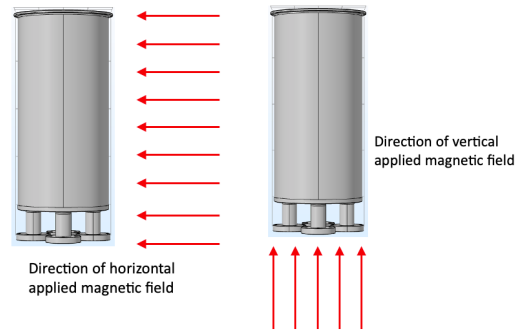

Poster available during the poster session on Wednesday!
Please come talk to Ruth there.

2023-08-01



Modelling thermal feedback in surface resistance studies on coaxial SRF cavities Mattias McMullin (MSc, UVic)

The rf surface resistance is highly dependent on the surface temperature

Question: How can we determine the RF surface temperature compared to the bath temperature?

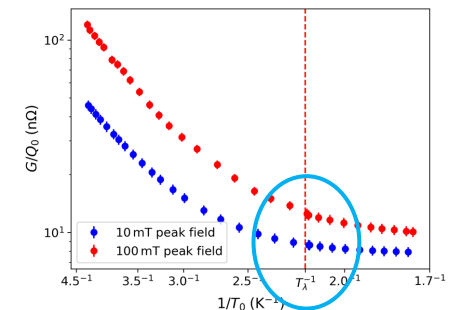
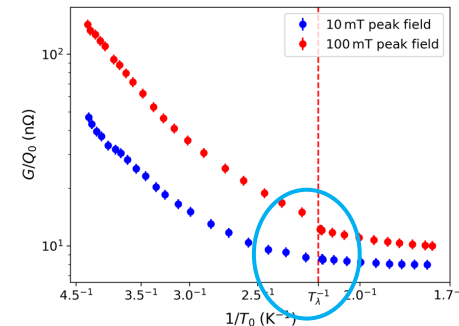
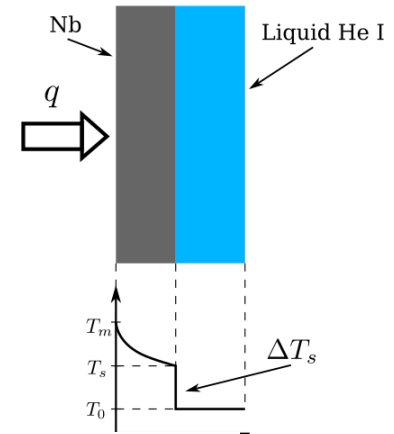

New data + model eliminates discontinuity when cooling regime changes.

Recognized at SRF 2023 conf with Student Poster Award (1st place)

New ' β -SRF' Facility Commissioned at β -NMR

Edward Thoeng
(PhD, UBC)

- New beamline extension installed at β -NMR facility for SRF materials characterization
- Unique facility in the world for depth profiling materials in parallel magnetic fields up to 200mT – SRF regime – critical field of Nb
- Collaboration between Accelerator Division and CMMS
- Commissioning and first experiments completed



Magnetic field screening for various applied fields

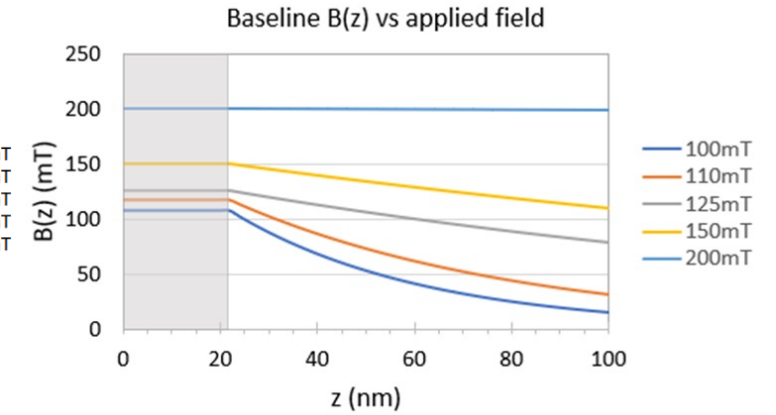
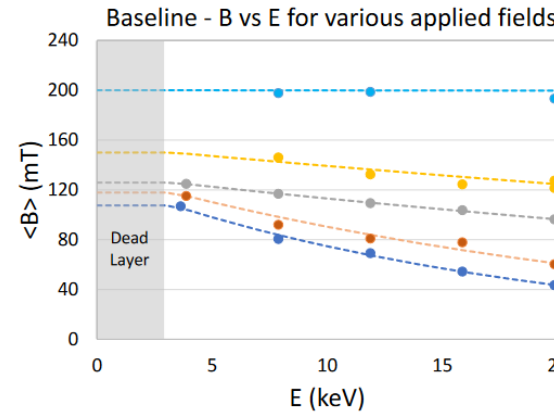

First paper

E. Thoeng, et al:
A New High Parallel-Field Spectrometer at TRIUMF's β -NMR Facility,
Rev. Sci. Instr. *Editors Pick*

Edward was recognized at SRF2023 with the Early Career Presenter Award.

2023-08-01

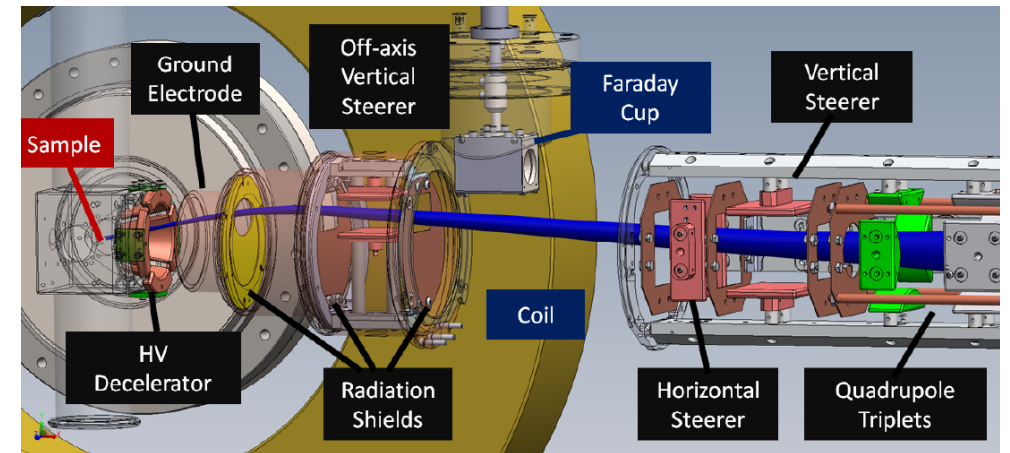
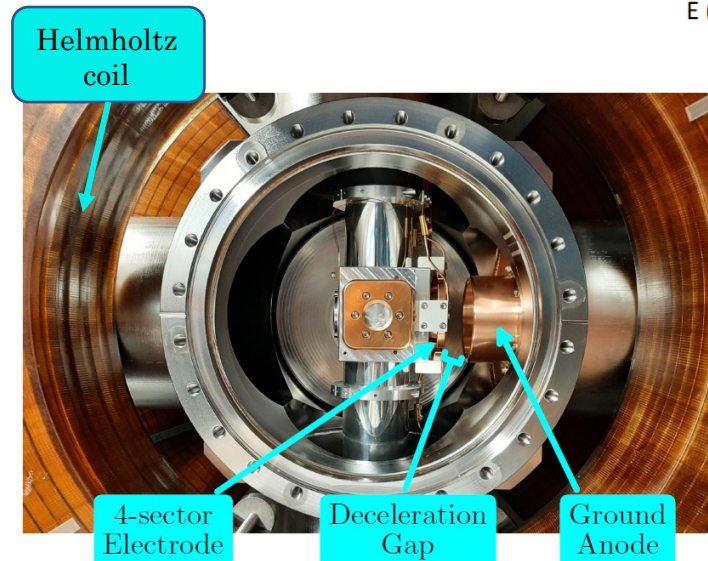

Discovery, accelerated

SRF Collaborations

Supporting the SRF community and engaging in cutting edge projects

- VECC cryomodules
- CERN Hi-Lumi crab cavity modules

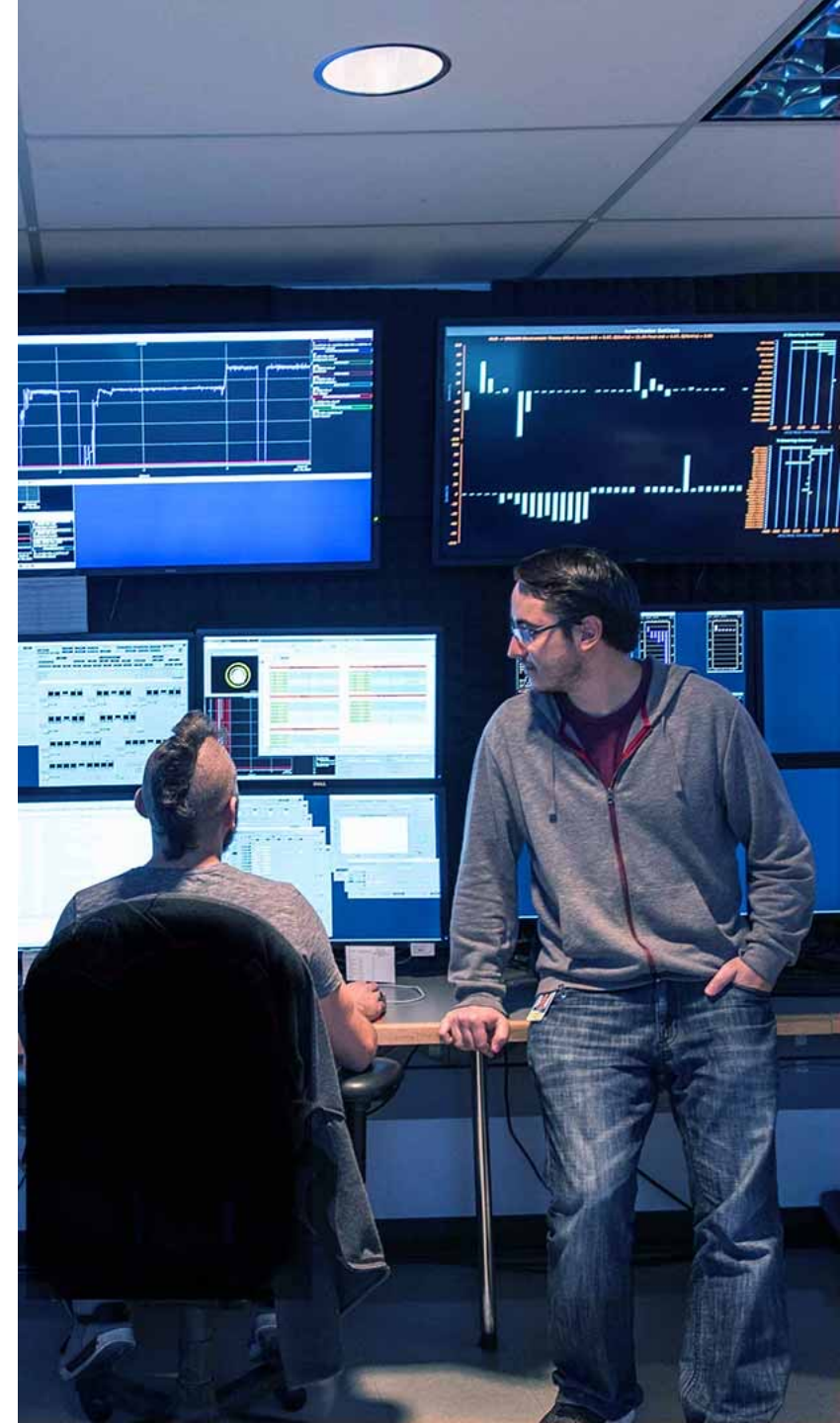

1.3 GHz Injector Cryomodule

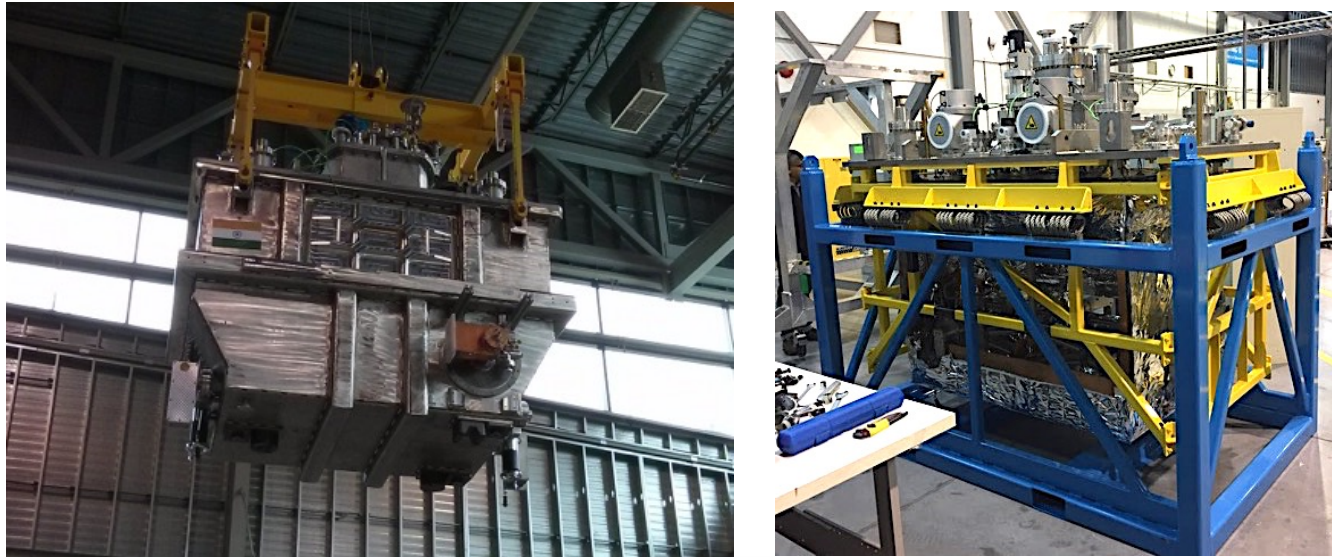

- TRIUMF and VECC (Kolkata) have had an active collaboration since 2008
- As part of the collaboration TRIUMF has completed two cryomodules, a 1.3GHz electron SRF module (ICM) and a 110MHz heavy ion module (QWR)
- The ICM was shipped in 2019 and the QWR will be shipped in December 2022
- TRIUMF is also completing RIB production modules for VECC

11

Quarter-wave Resonator Heavy Ion Cryomodule

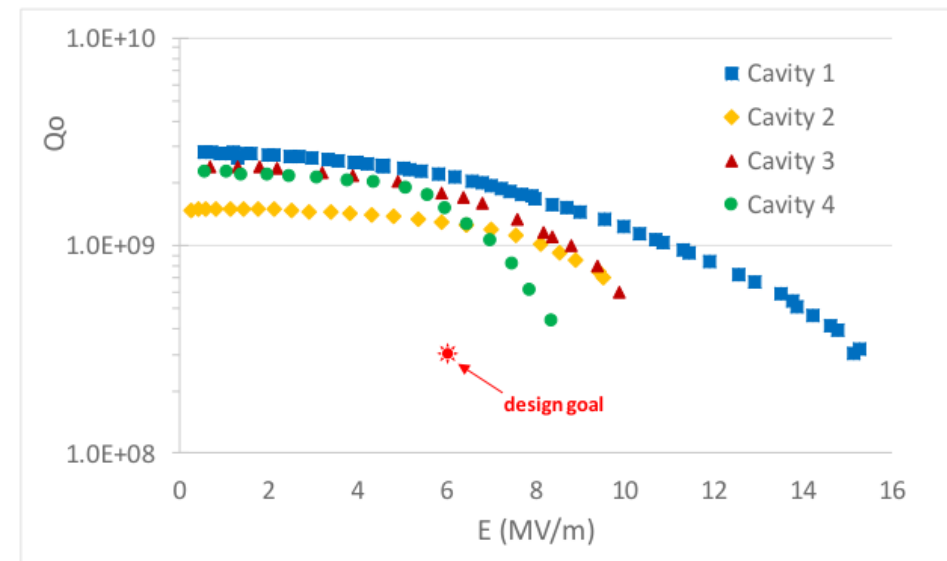
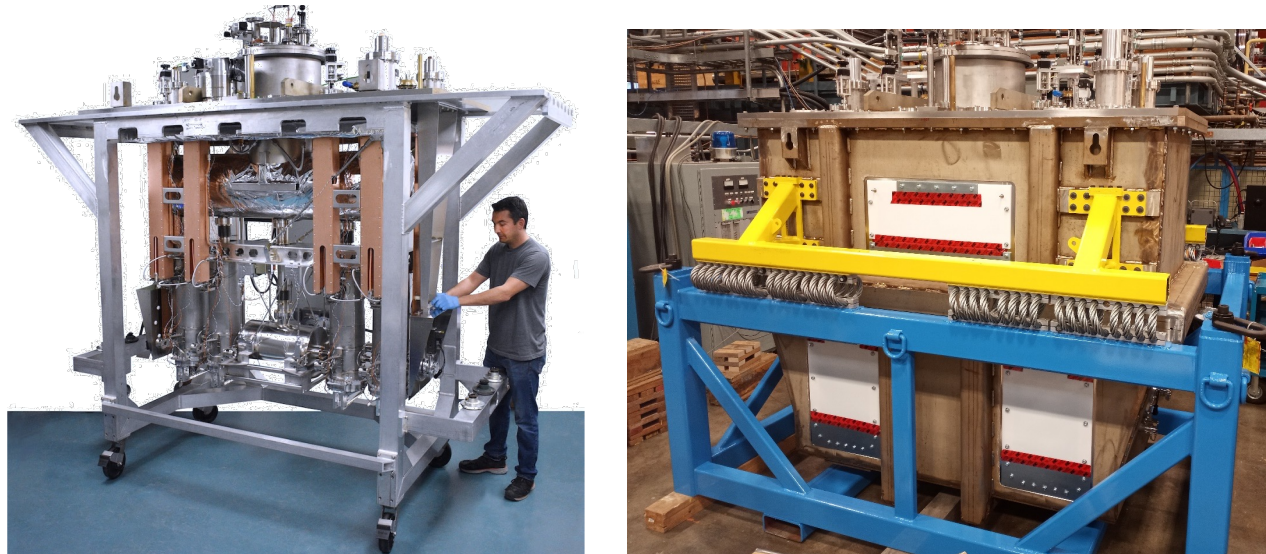

- TRIUMF was funded to produce and qualify 5 RF Dipole (RFD) cryomodules as in-kind contribution
- Preparing to build prototype cryomodule (TCM0) and to receive first cavities in 2023
- Procurement is in progress.
- Series production CMs will follow in 2024 and 2025
- Also Beam Physics collaboration – Hui Wen in next talk for more details

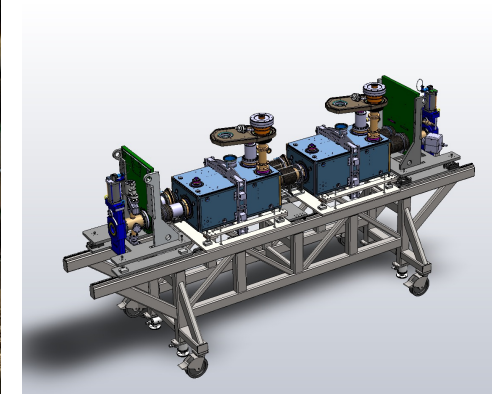
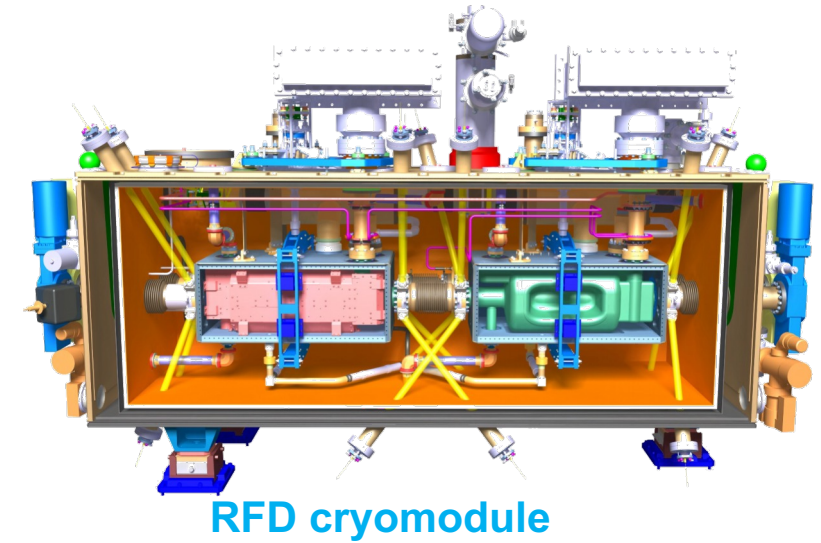

String assembly cart

Cavity handling

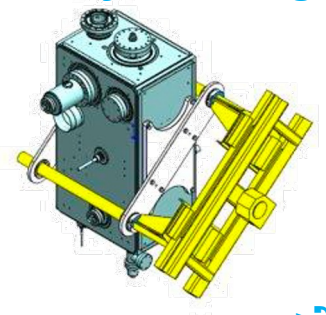

Outlook into the Future

- ISAC-II: Beyond 40MV
- eLinac: Reliable 30MeV operation
- Electron-Ion Collider Crab Cavity



- Cavity performance characterized in quality factor Q_0 and gradient E_{acc}
 - SCC1#5 was used for R&D, resulting in much higher performance
- Increasing cavity performance via different processes:
 - Informed by coax cavity R&D
 - Degassing in UHV at ~650-800C for hydrogen removal (~\$500k for furnace)
 - Low temperature bake (120C for 48hrs)
- Higher E_{acc} → higher Energy
- Higher Q_0 → more cryogenic margin for more cavities!

Performance of SCC1 cavities

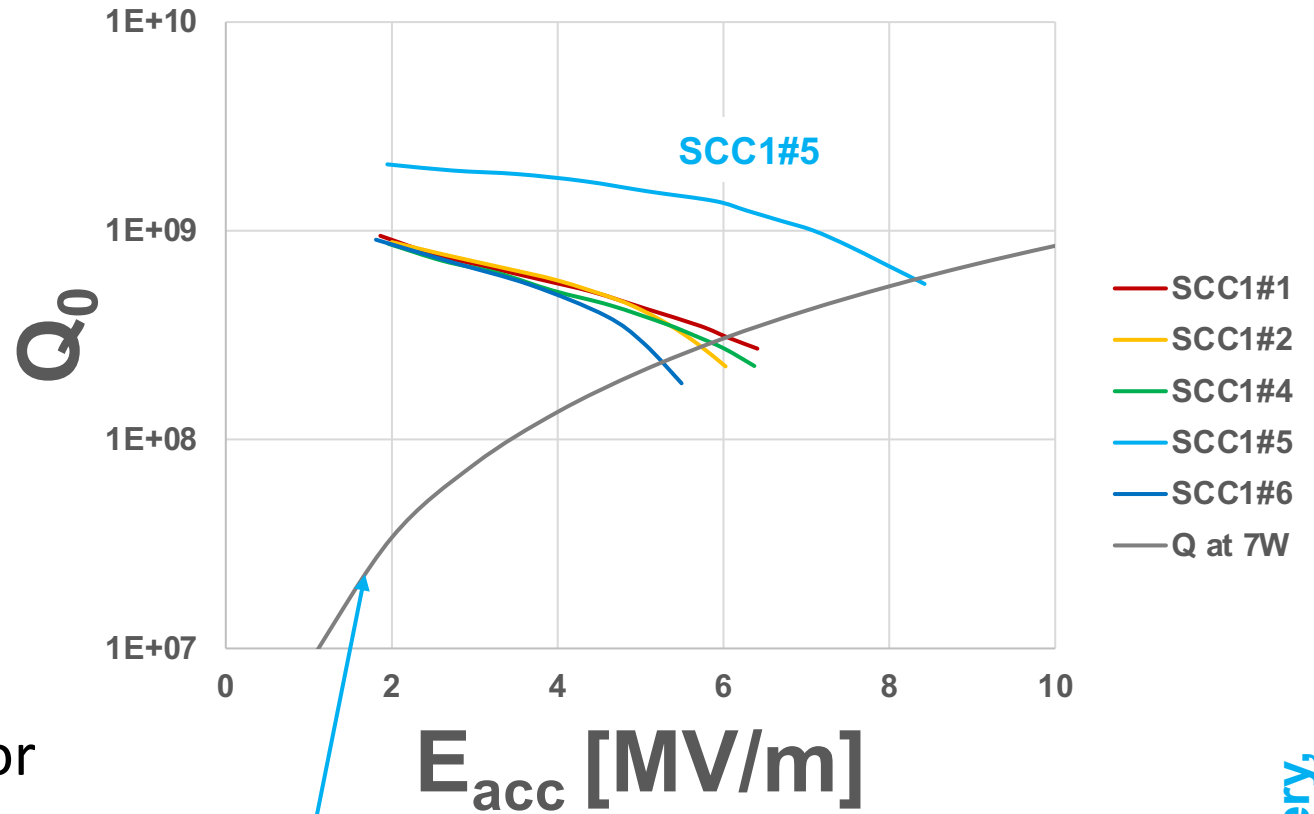

7W of cavity wall losses = cryogenic losses
 Typical operating curve for ISAC-II

Stable 30MeV operation is critical for RIB production:

- RIB yield is strongly dependent on beam energy
- We're operating at 30MeV – at the lower end of the yield curve

- Field emissions from contaminants in the SRF cavity limit RF performance to lower E_{acc}
- Prevention and mitigation critical to keeping performance high, to keep RIB yield high

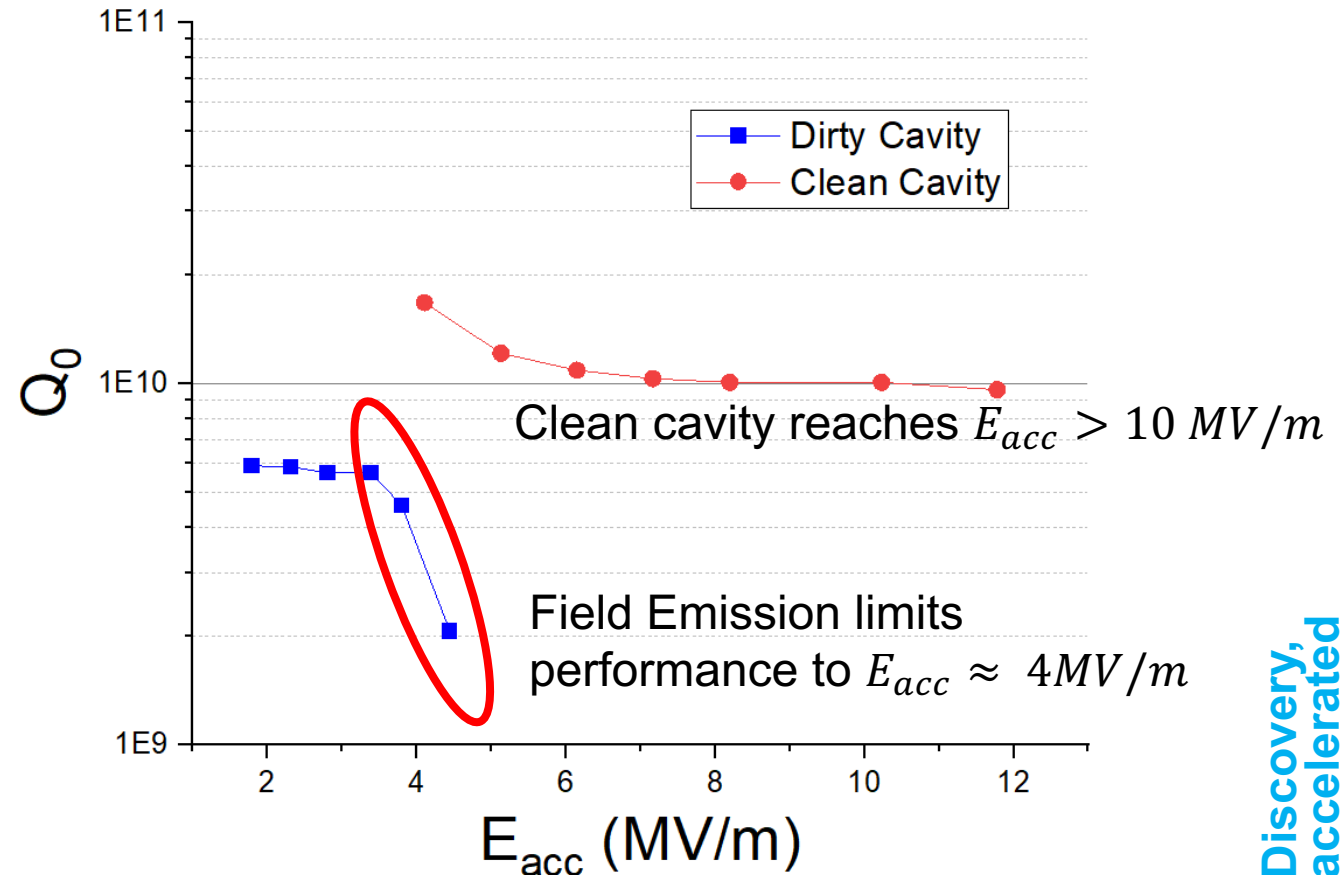
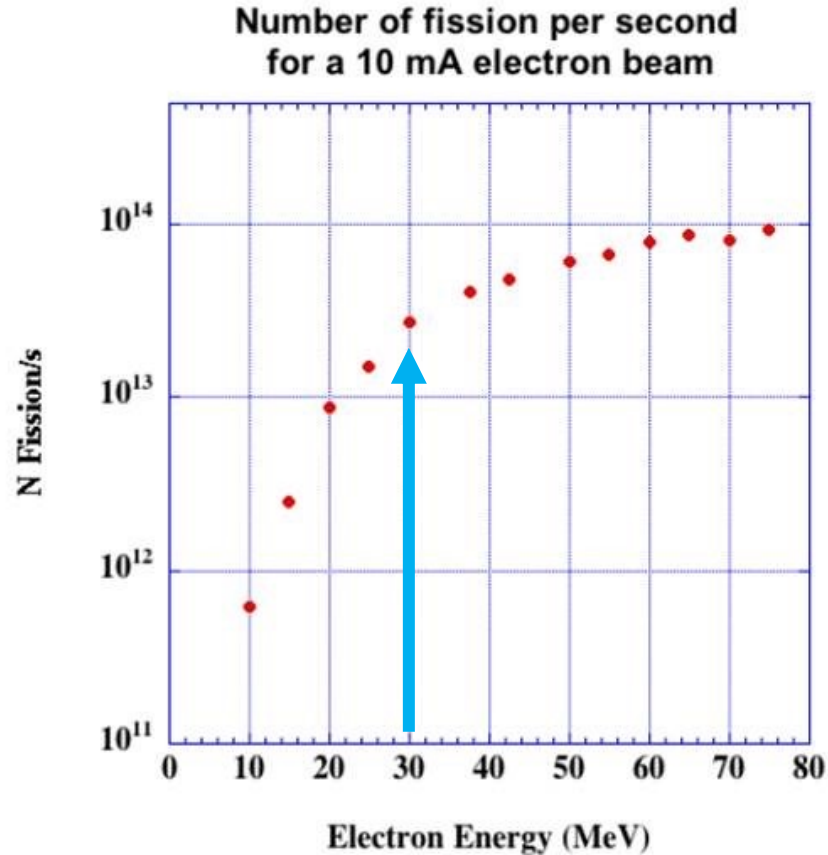

Development: Plasma Processing

Daniel Hedji (MSc – Uvic)

- Plasma processing with an Ar/O mixture can break up hydro-carbon based particulates and remove them.
- Would allow cavity cleaning without taking module off beamline (1 week instead of 2-3 months of work)

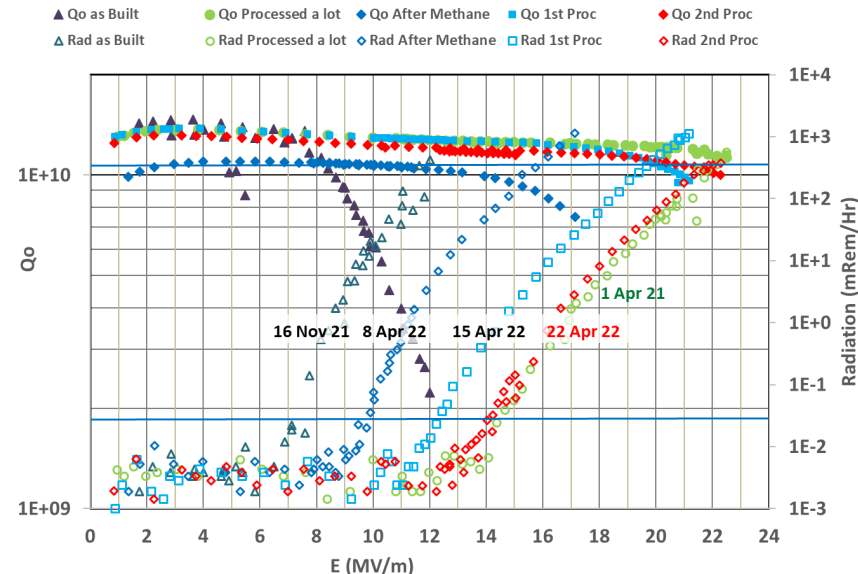
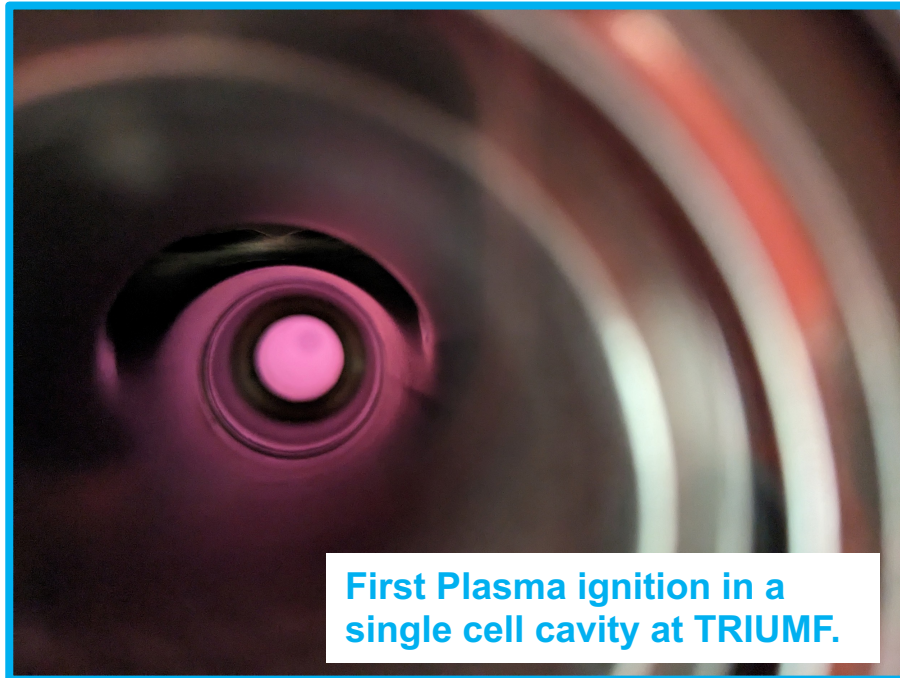
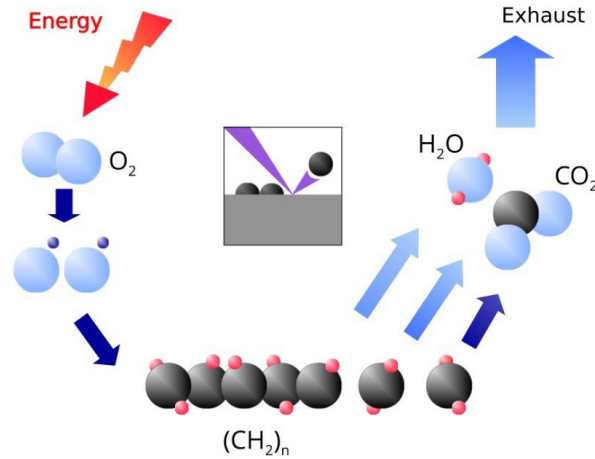

Results from JLab show decreased FE after plasma processing

Study: Field Emission and Dust migration

Aveen Mahon (MSc - Uvic)

- To prevent particulate migration, we need to know how they move
- Collaboration with CERN at the LHC and the University of Boulder, CO, to study the field emission and dust migration
- Samples are placed inside beamline near SRF accelerators and collected periodically to characterize the particulates

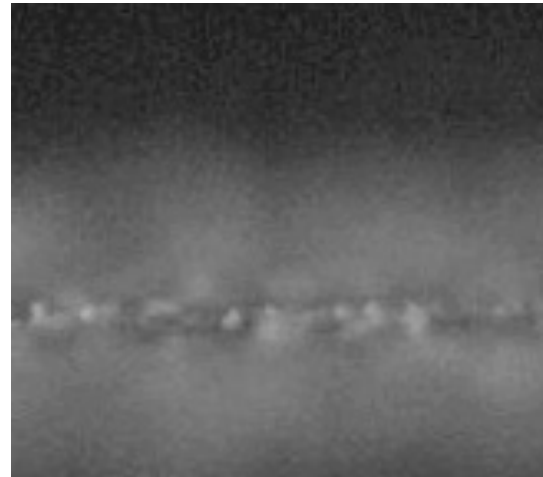
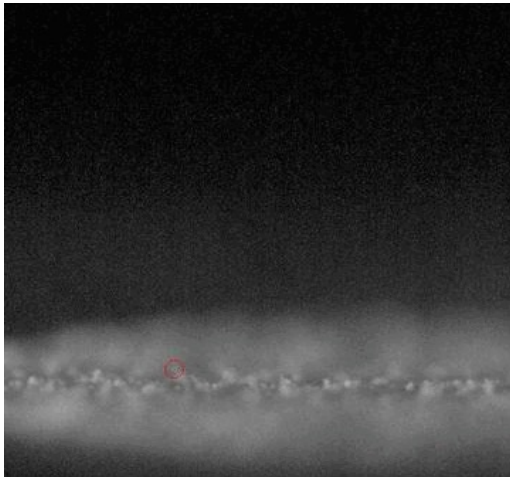

- A major new collider facility scheduled to be built at BNL to explore subatomic physics.
- TRIUMF working with EIC-Canada to seek Canadian funding to support in-kind contributions.
- TRIUMF's SRF group started work on the design of the 394MHz crab cavity – similar size to HL-LHC 400MHz crab cavity
- Challenging HOM design due to high beam current

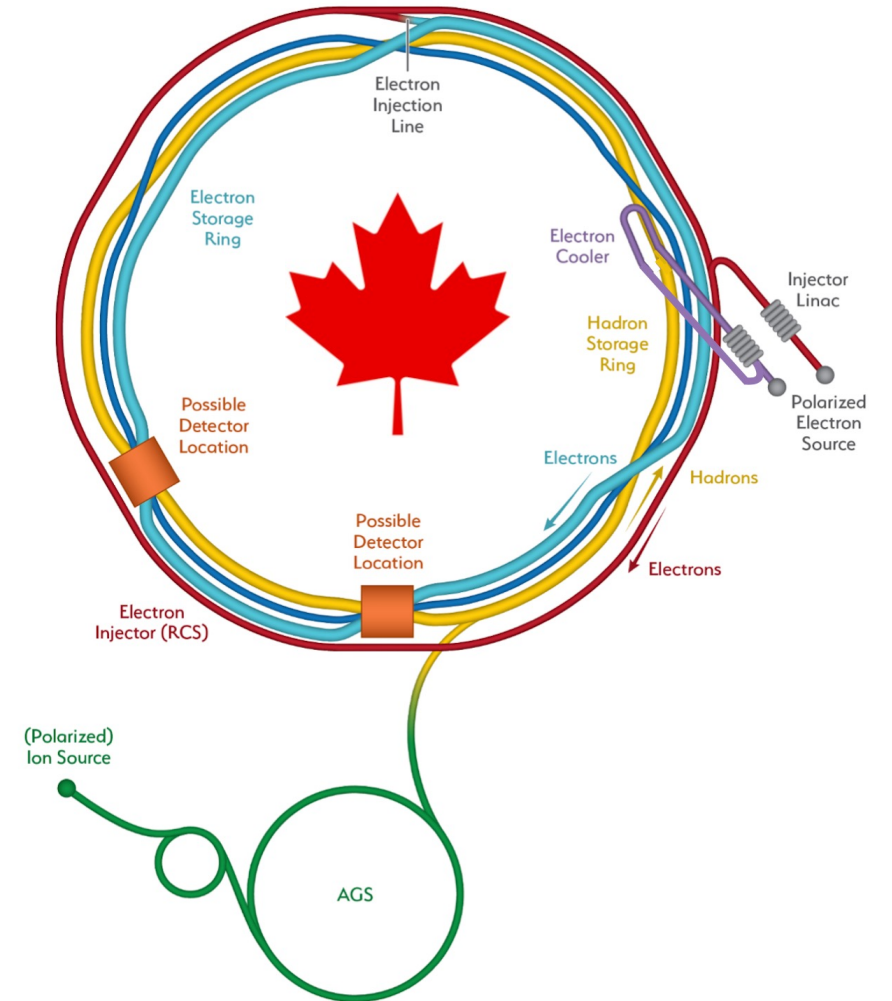
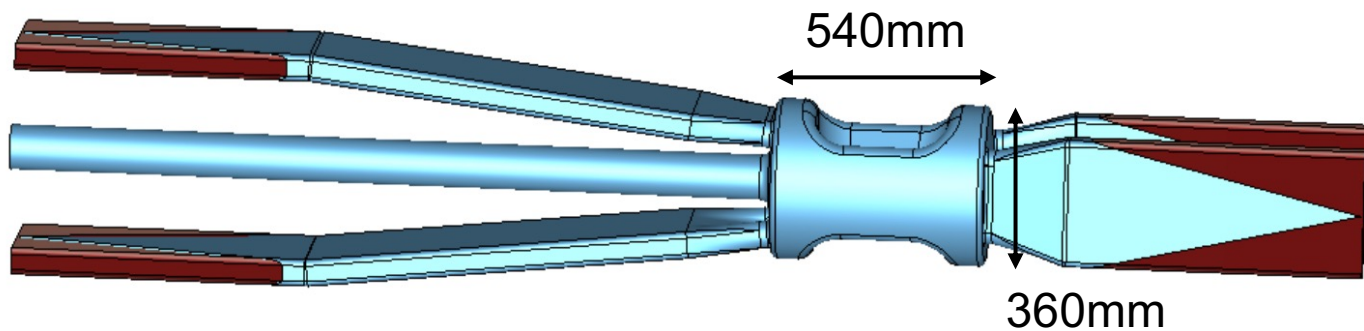

- Supporting SRF accelerators
 - ISAC-II
 - ARIEL eLINAC
- Training students and Post-Docs
 - Research program on Coax Cavities
 - SRF material science at β NMR
- Contributing to SRF community
 - VECC
 - HL-LHC
 - EIC

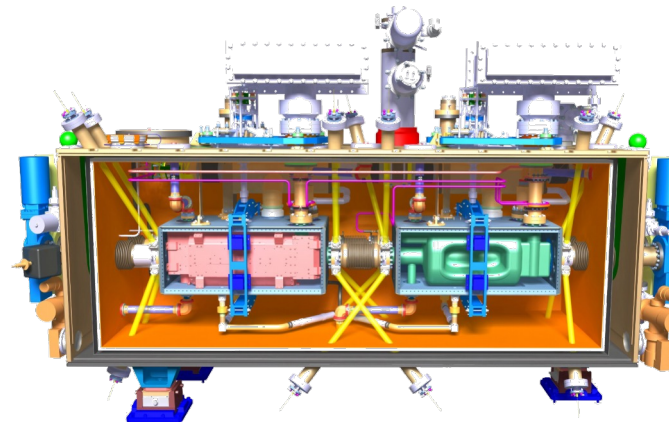
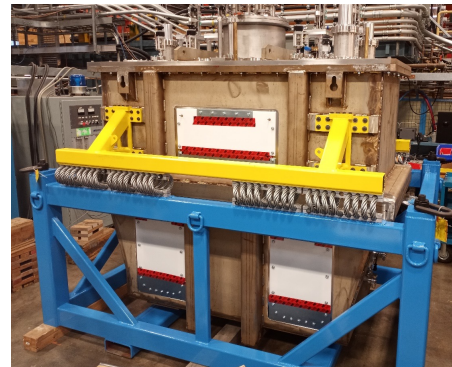
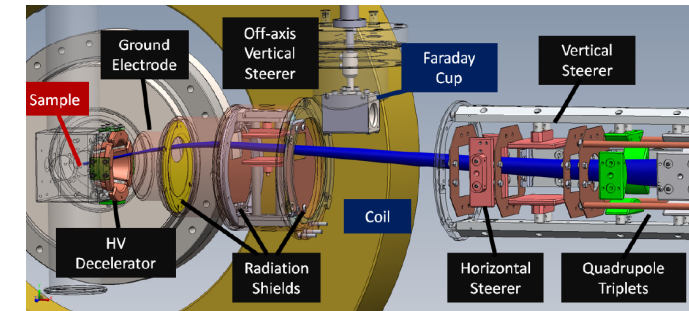
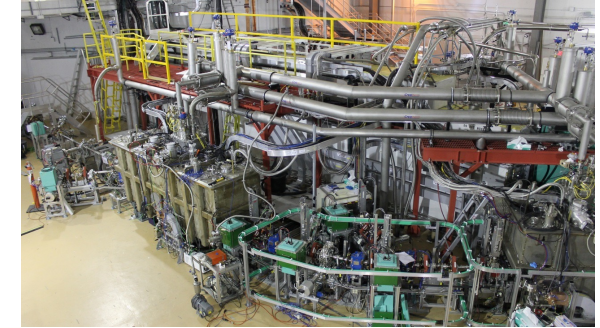

Thank you
Merci

2023-08-01

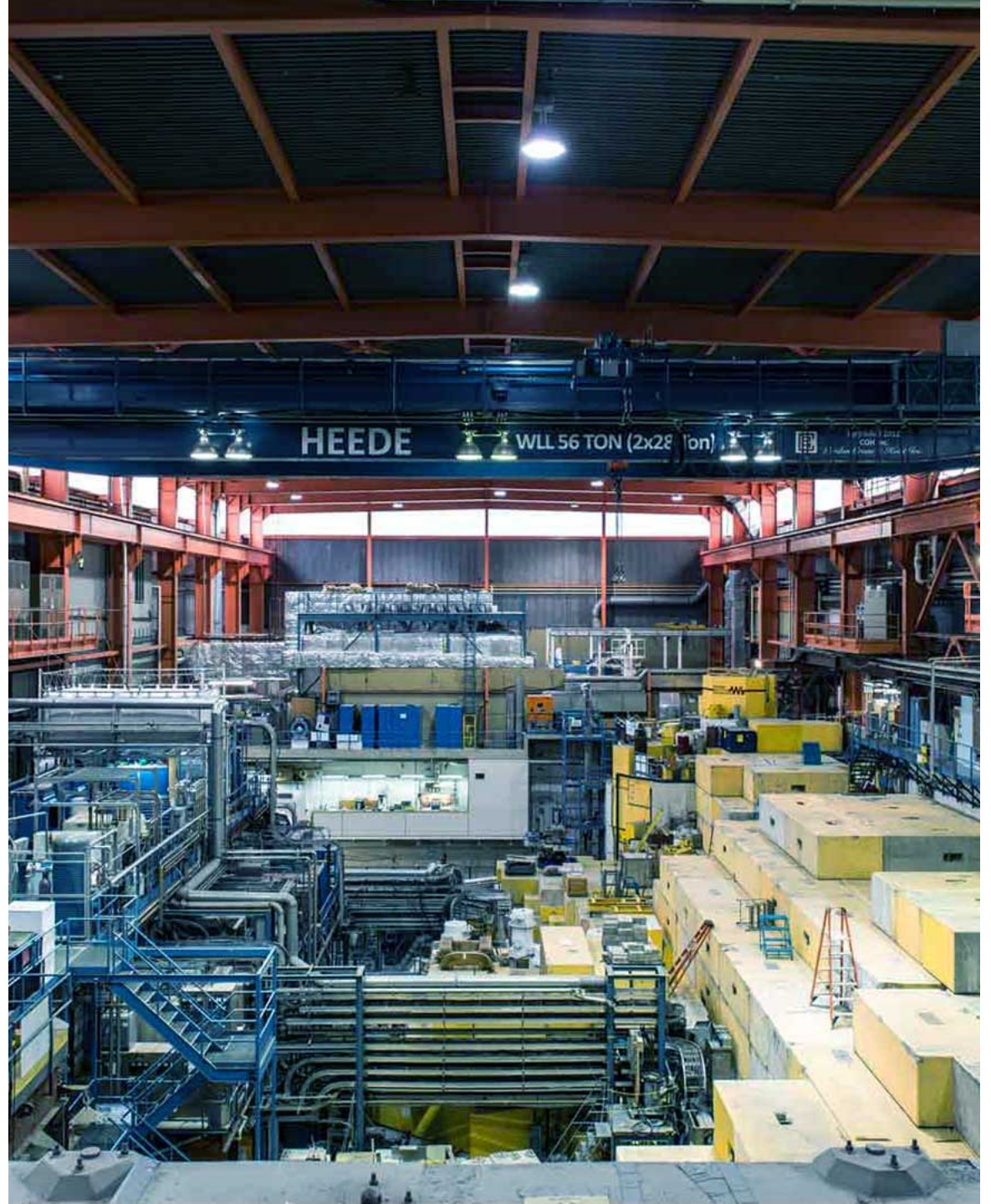

- 3 simultaneous RIBs to experiments
- New RFQ to 400keV/u for $A/q < 7$
- SCA w/ 7 QWRs @ 71MHz, β 4.1%

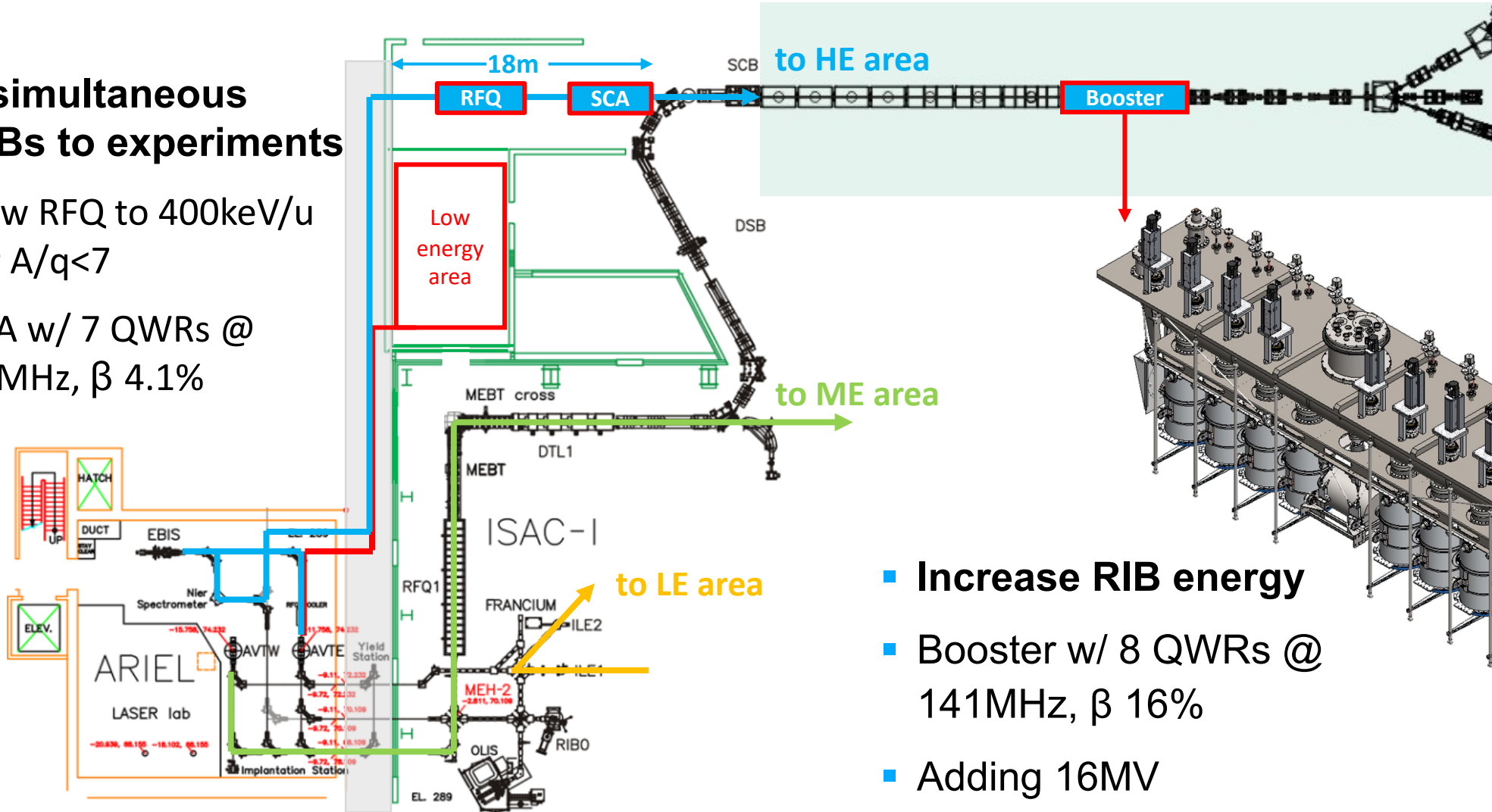

- Increase RIB energy
- Booster w/ 8 QWRs @ 141MHz, β 16%
- Adding 16MV