

Improved Measurement of the π^+ Lifetime

Experiment S2307

C. B.-Champagne¹ D. Bryman^{1,2} T. Gorringer³ D. Hertzog⁴
P. Kammel⁴ J. LaBounty⁴ C. Malbrunot¹ S. M. Mazza⁵ S. Mehrotra⁶
R. Mischke¹ G. Morris¹ M. Nizam⁵ T. Numao¹ J. Ott⁵ K. Pachal¹
X. Qian⁷ B. Schumm⁵ A. Seiden⁵ V. Tishchenkov⁷ Bob Velghe^{*1}

TRIUMF PP-EEC Meeting
April 18, 2023

*bvelghe@triumf.ca

C. B.-Champagne¹ D. Bryman^{1,2} T. Gorringer³ D. Hertzog⁴
P. Kammel⁴ J. LaBounty⁴ C. Malbrunot¹ S. M. Mazza⁵ S. Mehrotra⁶
R. Mischke¹ G. Morris¹ M. Nizam⁵ T. Numao¹ J. Ott⁵ K. Pachal¹
X. Qian⁷ B. Schumm⁵ A. Seiden⁵ V. Tishchenkov⁷ Bob Velghe^{†1}

¹TRIUMF

²University of British Columbia

³University of Kentucky

⁴University of Washington

⁵University of California, Santa Cruz

⁶Stony Brook University

⁷Brookhaven National Laboratory

Balance of early-career and experienced scientists. Multiple participants were part of the MuLan collaboration (muon lifetime experiment).

C. B.-Champagne is a PIF & NIF expert, G. Morris is a TRIUMF's μ SR beam lines expert, and T. Numao led the past TRIUMF measurement.

Charged Pion Lifetime

The PDG 2022 average is $\tau_\pi = 26.033 \pm 0.005$ ns ($\delta\tau/\tau = 0.02\%$)

π^\pm MEAN LIFE

Measurements with an error $> 0.02 \times 10^{-8}$ s have been omitted.

<u>VALUE (10^{-8} s)</u>	<u>DOCUMENT ID</u>	<u>TECN</u>	<u>CHG</u>	<u>COMMENT</u>
2.6033 \pm 0.0005 OUR AVERAGE	Error includes scale factor of 1.2.			
2.60361 \pm 0.00052	¹ KOPTEV	95	SPEC +	Surface μ^+ 's
2.60231 \pm 0.00050 \pm 0.00084	NUMAO	95	SPEC +	Surface μ^+ 's
2.609 \pm 0.008	DUNAITSEV	73	CNTR +	
2.602 \pm 0.004	AYRES	71	CNTR \pm	
2.604 \pm 0.005	NORDBERG	67	CNTR +	
2.602 \pm 0.004	ECKHAUSE	65	CNTR +	
• • • We do not use the following data for averages, fits, limits, etc. • • •				
2.640 \pm 0.008	² KINSEY	66	CNTR +	

¹ KOPTEV 95 combines the statistical and systematic errors; the statistical error dominates.

² Systematic errors in the calibration of this experiment are discussed by NORDBERG 67.

TRIUMF experiment \rightarrow M. C. Fujiwara, T. Numao, A. J. Macdonald, G. M. Marshall, A. Olin, Phys. Rev. D **52** (1995) 4855

Charged Pion Lifetime & Lepton Universality

Powerful test of the electron-muon universality → Precisely measure

$$R_{e/\mu} = \frac{\Gamma(\pi^+ \rightarrow e^+ \nu(\gamma))}{\Gamma(\pi^+ \rightarrow \mu^+ \nu(\gamma))} \propto f(m_\pi, m_\ell) \cdot \frac{g_e}{g_\mu},$$

where g_e and g_μ are the electron and muon couplings to the W boson.

The uncertainty on the SM prediction ($g_e = g_\mu$) is less than 0.01%:

$$R_{e/\mu}^{\text{SM}} = (1.23524 \pm 0.00015) \times 10^{-4}.$$

V. Cirigliano et al., Phys. Rev. Lett. **99** (2007) 231801 V. Cirigliano et al., JHEP **10** (2007) 005 W. J. Marciano et al., Phys. Rev. Lett. **71** (1993) 3629

Rich experimental history at TRIUMF (PIENU '86, '94, '15). PDG average:

$$R_{e/\mu}^{\text{PDG}} = (1.2327 \pm 0.0023) \times 10^{-4}.$$

New measurement planned by the PIONEER collaboration, approved at PSI

→ Reduce the $R_{e/\mu}$ experimental uncertainty to 0.01%.

Impact of τ_π on the $R_{e/\mu}$ Error Budget

Basic principle, count $\pi \rightarrow e$ and $\pi \rightarrow \mu \rightarrow e$ events, τ_π enters in the ratio:

$$R_{e/\mu} = \frac{\lambda_\mu}{\lambda_\pi - \lambda_\mu} \frac{N_{\pi e}}{De^{\lambda_\mu t_s} - N_{\pi\mu e}} \left(1 - e^{-(\lambda_\pi - \lambda_\mu)t_s}\right)$$

E. Di Capua et al, Phys. Rev. **133** (1967) B1333

Impact on PIENU syst. uncertainty:

$$\delta R = \pm 0.57 \times 10^{-8} \quad (\delta R/R = 0.005\%)$$

In the PIONEER context, $\delta\tau_\pi/\tau_\pi$ becomes relevant:

Error Source	PIENU 2015 PIONEER Estimate	
	%	%
Statistics	0.19	0.007
Tail Correction	0.12	<0.01
t_0 Correction	0.05	<0.01
Muon DIF	0.05	0.005
Parameter Fitting	0.05	<0.01
Selection Cuts	0.04	<0.01
Acceptance Correction	0.03	0.003
Total Uncertainty	0.24	≤ 0.01

(Modern experiments are fitting a model to the time spectra.)

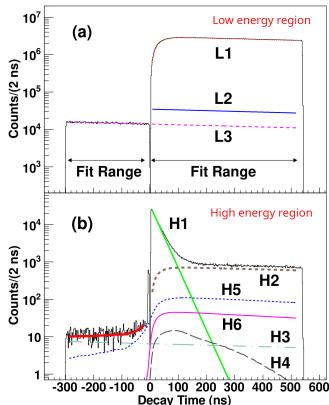

Proposed Experimental Method

Take advantage of TRIUMF's micro-bunched proton beam.

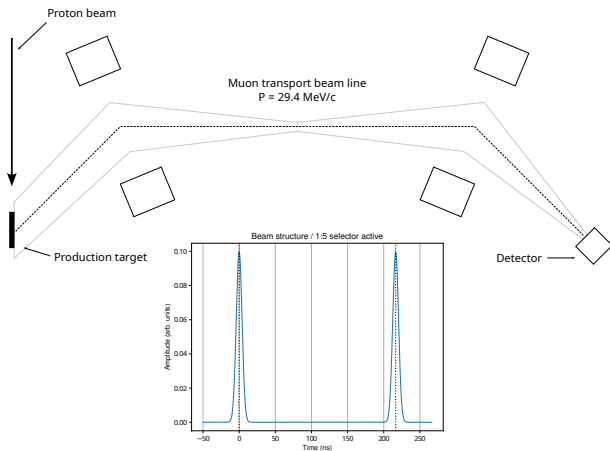

Extract the π^+ lifetime from the **surface-muon yield** of a production target.

Proposed Experimental Method

Take advantage of TRIUMF's micro-bunched proton beam.

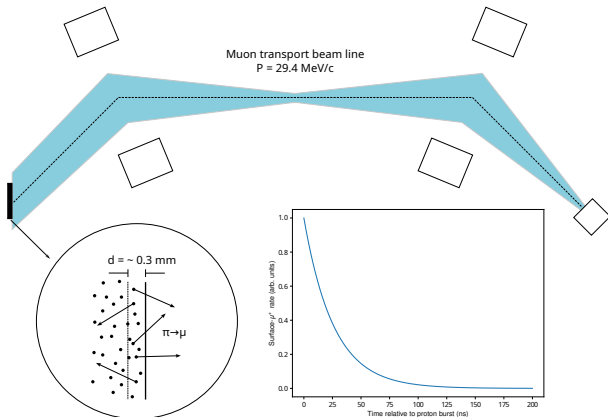

Extract the π^+ lifetime from the **surface-muon yield** of a production target.

TRIUMF's Beam Structure

Cyclotron driving freq. is 23 MHz (one bunch every ≈ 43.3 ns)
→ The inspection window is too short for a precise τ_π measurement.

But, the “1:5 selector”, installed on the injection line, allows to suppress 4/5 bunches, lengthening the inspection period to \approx **215 ns**.

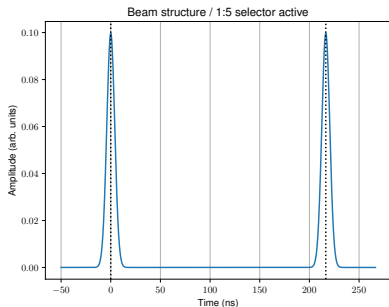
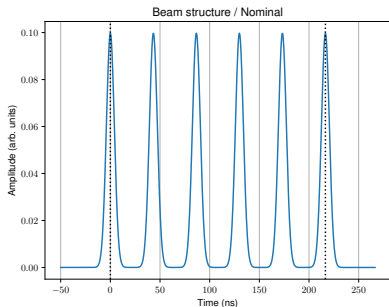

Understanding the *beam leakages* is key for this experiment.

TRIUMF's M9A, M15 and M20 (μ SR) have the desired characteristics:

- ▶ Tuned to $P \approx 30$ MeV/ c , thin vacuum windows,
- ▶ DC separators for positrons rejection (500:1),
- ▶ Small beam spot at the final focus point.

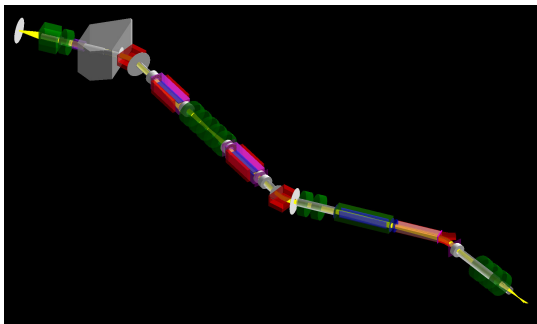

G4beamline model of M20 - G. Morris and TRIUMF's μ SR group.

We propose a measurement campaign to determine precisely (a) $\delta P/P$, (b) the positron contamination, and (c) the surface- μ^+ rate with the slits in the extended position.

Conceptual Detector Layout

Baseline → Telescope made of 4 thin plastic scintillator counters, each read-out by a SiPMs. Pulse timing and amplitude (dE/dx) recorded by an ADC.

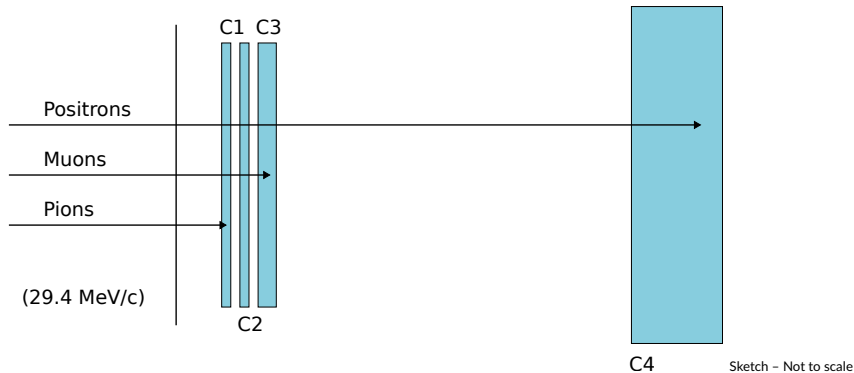

As an example, Numao et al. used 0.25, 0.13, 0.50, and 10 mm thick counters for C1, C2, C3 and C4, respectively.

Final thicknesses will be fine-tuned to the beam characteristics.

Statistical Uncertainty – Fitting Interval

The 1:5 selector is essential.

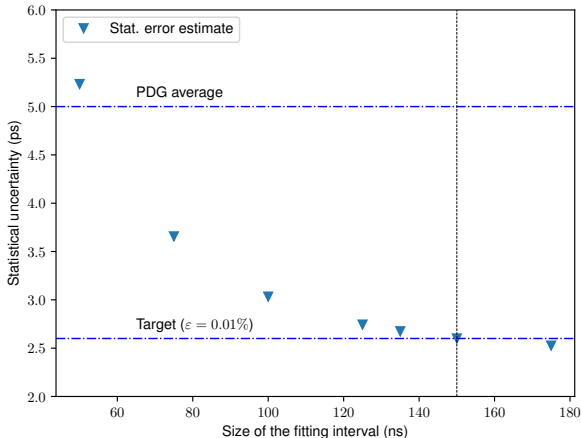

All subsequent plots are based on $2 \times 10^8 \pi^+ \rightarrow \mu^+ \nu$ events and a 150 ns fitting interval.

Systematic Uncertainties – Overview

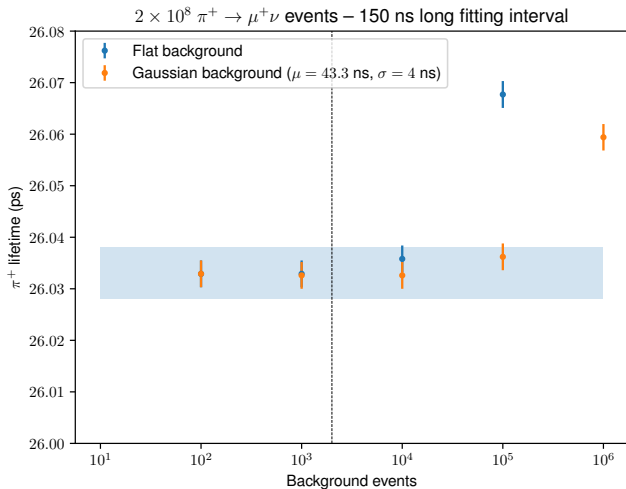

→ Keep the contamination fraction of the μ^+ sample below 10^{-5} .

1:5 Selector and Beam leakages

Possible online monitoring of the 1:5 selector performance in BL2C.

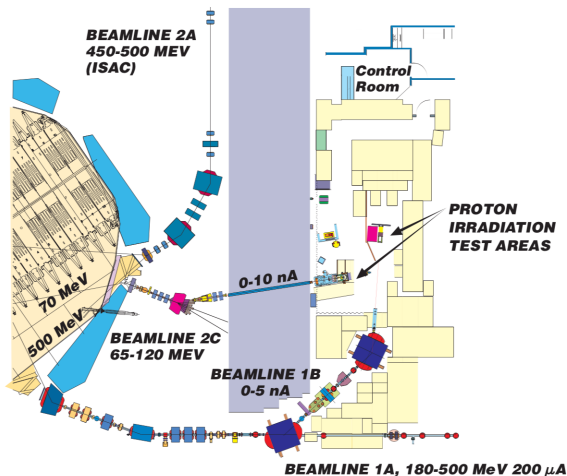

Arrangements made to measure the *beam leakage* directly with protons at PIF & NIF.

Systematic Uncertainty – Positrons & Cloud Pions

The positron background has two components:

- ▶ Prompt, $\pi^0 \rightarrow \gamma(\gamma \rightarrow e^+e^-) \rightarrow$ Discard the first 15 ns after the proton burst,
- ▶ Flat, $\mu^+ \rightarrow e^+\nu\bar{\nu}$ ($\tau_\mu \gg \tau_\pi$) \rightarrow Negligible, stopping rate in C3, dE/dx .

Positrons in the beam are further suppressed by the DC separator (factor 500:1).

A cloud of (slow) π^+ hang around the target and decay into μ^+ s, some of which are accepted by the beamline.

This needs to be measured, two options:

- ▶ Look at the μ^+ spectrum just above the surface- μ^+ edge and extrapolate down,
- ▶ Look at the μ^- spectrum, it requires inverting the beamline polarity.

Systematic Uncertainty – Time of flight

Keep the surface- μ arrival time dispersion < 5 ns.

- ▶ $\delta P/P$ will be measured, 1% (FWHM) $\rightarrow 1.4$ ns,
- ▶ Path variations will be studied with a G4beamline simulation.

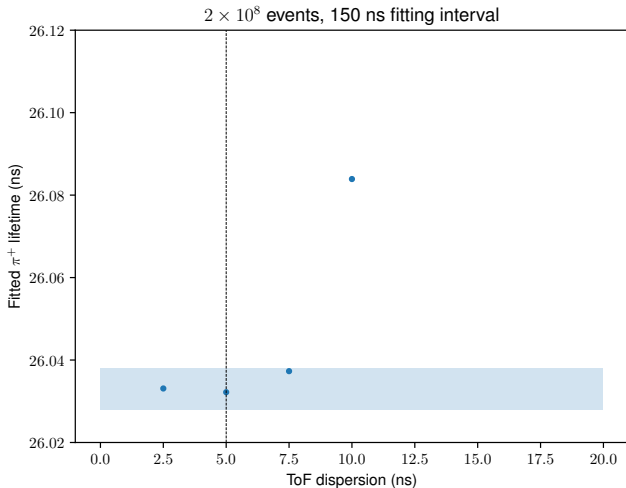

Summary – Projected Systematic Uncertainties

The pion diffusion and pion cloud component estimates are tentatively based on Numao et al.

Sources	Syst. uncertainty estimates (ps)
Beam leakage	< 0.5
Muons from the π^+ cloud	≤ 2
Time of flight	< 0.5
Positrons	< 0.4
Pions	< 0.1
Pion diffusion	≤ 0.3
Total	< 2.2

We will use a blind analysis method.

Timeline & Beamtime Request

We propose a two-step approach:

1. Beam extinction and μ SR beamline studies. This can be started anytime.
2. Once those studies are done, organize the π^+ lifetime measurement.

Activity	Requested Allocation	1:5 Selector	PIF & NIF
Beam extinction studies	Machine devel.	Yes	Yes
Beamline studies	3 shifts	No	No
Detector setup	2 shifts	No	Yes
Pion lifetime	18 shifts	Yes	Yes

The PIONEER experiment will push the boundaries of the lepton universality tests in the coming years.

A 0.01% π^+ lifetime measurement is an important piece of the puzzle.

TRIUMF provides an ideal environment to improve the π^+ lifetime.

- ▶ 1:5 selector allows to extend the burst period,
- ▶ Extensive local μ SR expertise.

The 0.01% precision goal looks achievable with a week of beam time.

- ▶ Collect a $> 2 \times 10^8$ sample of $\pi^+ \rightarrow \mu^+ \nu$ events,
- ▶ Dedicated studies for the pion cloud background component,
- ▶ Online beam extinction monitoring.



1:5 Selector

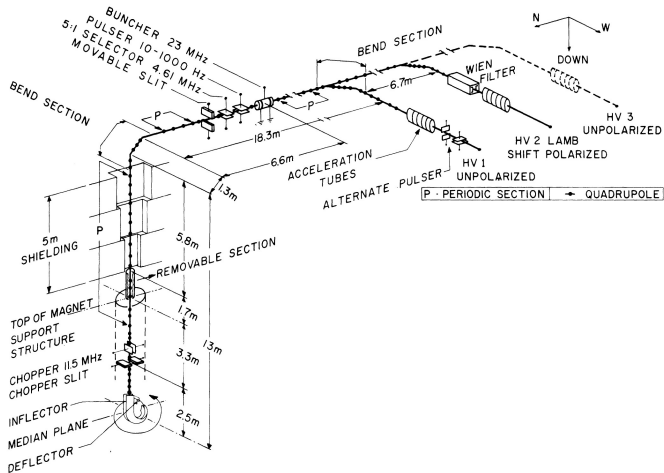

Sample Size

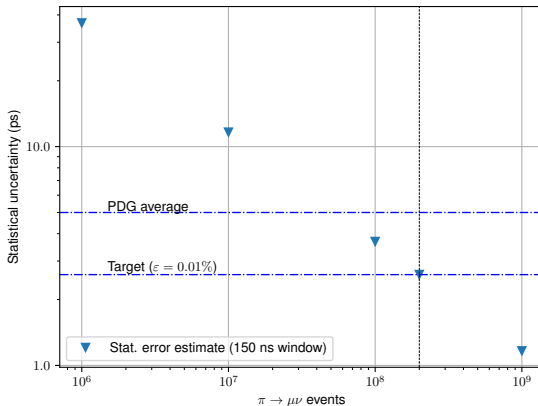

We need to collect a minimum of $2 \times 10^8 \pi^+ \rightarrow \mu^+ \nu$ events. Assuming a surface- μ^+ rate of 10 kHz and a detection efficiency of $\epsilon = 0.5$, it would take about 11 hours (with a 100% cyclotron duty cycle).

Previous Measurements Based on Surface- μ^+ s

The two most recent experiments, conducted by Koptev et al. (JETP Lett. **61** (1995) 877) and Numao et al. (Phys. Rev. D **52** (1995) 4855), used momentum-analyzed surface-muons. ‡

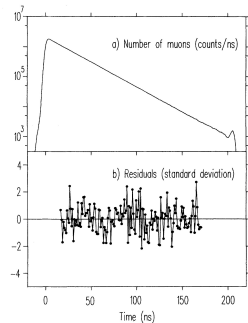
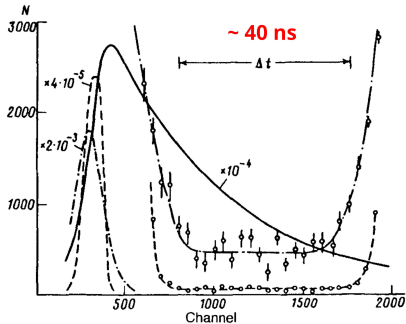

Koptev et al., statistics limited.

$$\tau_{\pi^+} = 26.0361 \pm 0.0052$$

Numao et al., **150 ns** examination window, systematics limited.

$$\tau_{\pi^+} = 26.0231 \pm 0.0050 \pm 0.0084$$

‡ Older experiments examined the $\pi^+ \rightarrow \mu^+ + \nu_\mu$ or $\pi^+ \rightarrow \mu^+ + \nu_\mu + e^+ + \nu_e$ (stopped pions) sequence, or the π^\pm attenuation along a decay volume, see PDG for details.

We will digitize the PMT/SiPM waveforms, while the trigger definition will be based on analog signal coincidence logic. The acquisition can run on a standard PC and will be controlled by the MIDAS software package.

Main requirements:

- ▶ Able to digitize 6 channels (counters + cyclotron's RF pulses),
- ▶ ADC sampling rate ≥ 500 MS/s,
- ▶ ADC resolution ≥ 10 -bit,
- ▶ Good clock stability (e.g. SRS CG635),
- ▶ Able to sustain a 10 kHz trigger rate (average).



CAEN V1730

Data Blinding Procedure

Current thought: Make the exact master clock frequency F unknown to the experimenters ($F \rightarrow \alpha F$). The hidden parameter α is needed to convert the final τ_π value to seconds.

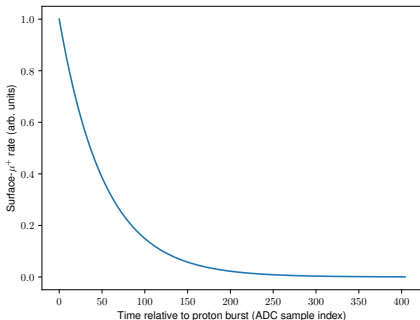

$$t_i = i \times \Delta T = \frac{i}{F_s},$$

where i is the ADC sample index and F_s is the ADC sampling frequency (which is set by the master clock).

Surface-muon Beams

Muon beam formed by the decay of pions that stops near the surface of a production target.

A. E. Pifer, T. Bowen, K. R. Kendall, NIM 135 (1976) 39

- ▶ Maximum μ^+ kinetic energy 4.1 MeV
→ High stopping density,
- ▶ Well defined source which can be imaged at the final focus.

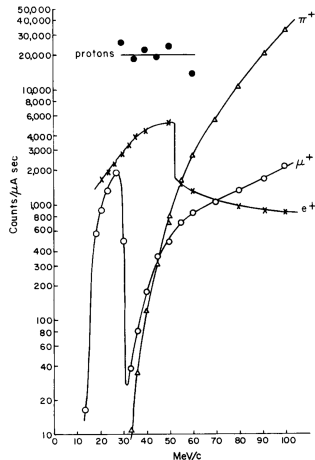

Charged Pion Decay – Formulae

At first order, the $\pi^+ \rightarrow \ell^+ \nu$ decay rate can be written as:

$$\Gamma(\pi^+ \rightarrow \ell^+ \nu) = \frac{G_F^2 |V_{ud}|^2 f_\pi^2}{4\pi} m_\pi m_\ell^2 \left(1 - \frac{m_\ell^2}{m_\pi^2}\right)^2,$$

where, G_F is the Fermi constant; V_{ud} is the CKM matrix element; and f_π^2 is the pion form factor.

See e.g. V. Cirigliano et al., JHEP 10 (2007) 00

The $\pi^+ \rightarrow \pi^0 e^+ \nu$ decay rate can be written as:

$$\Gamma(\pi^+ \rightarrow \pi^0 e^+ \nu) = \frac{G_F^2 |V_{ud}|^2}{30\pi^3} \left(1 - \frac{\Delta}{2m_{\pi^+}}\right)^3 \Delta^5 f(\varepsilon, \Delta) (1 + \delta),$$

where $\Delta = m_{\pi^+} - m_{\pi^0}$; $\varepsilon = m_e^2/\Delta$; and δ encodes the radiative corrections. See A. Sirlin, 1978, for the form of f .

A. Sirlin, Rev. Mod. Phys 50 (1978) 573

Charged Pion Lifetime & V_{ud}

The tension in the CKM matrix first-row unitarity relation could be connected to a violation of the lepton flavor universality.

[arXiv:2111.05338]

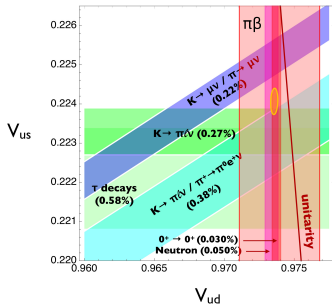

The CKM matrix element V_{ud} can be cleanly extracted from the pion beta decay branching ratio \mathcal{B} :

$$\Gamma(\pi^+ \rightarrow \pi^0 e^+ \nu) = \frac{\mathcal{B}(\pi^+ \rightarrow \pi^0 e^+ \nu)}{\tau_\pi} \propto |V_{ud}|^2.$$

The experimental \mathcal{B} , $(1.036 \pm 0.006) \times 10^{-8}$, is not competitive (red strip).

D. Pöcanić et al., Phys. Rev. Lett. **93** (2004) 181803

In a second phase, PIONEER plans to improve $\mathcal{B}(\pi^+ \rightarrow \pi^0 e^+ \nu)$. A new π^+ lifetime measurement is needed to achieve the best precision on V_{ud} .

Numao et al. Systematic Uncertainties

TABLE I. Systematic uncertainties.

Sources	Uncertainties (ns)
Beam leakage, ^a slow π^a	0.0083
Prompt positron background	0.0002
Flat positron background	0.0003
Pion background	0.0002
Extra muons	0.0001
Other pion sources	0.0001
Diffusion	0.0003
Total uncertainty	0.0084

^aIncluded in the fit.

Systematic Uncertainty – Beam leakage – Example

