

# Quantum Machine Learning Towards the Development of Automated Analysis of Data from Large-Scale Gamma-Ray Spectrometers

University of Guelph, Samantha Buck  
WNPPC 2024: Feb 16, 2024

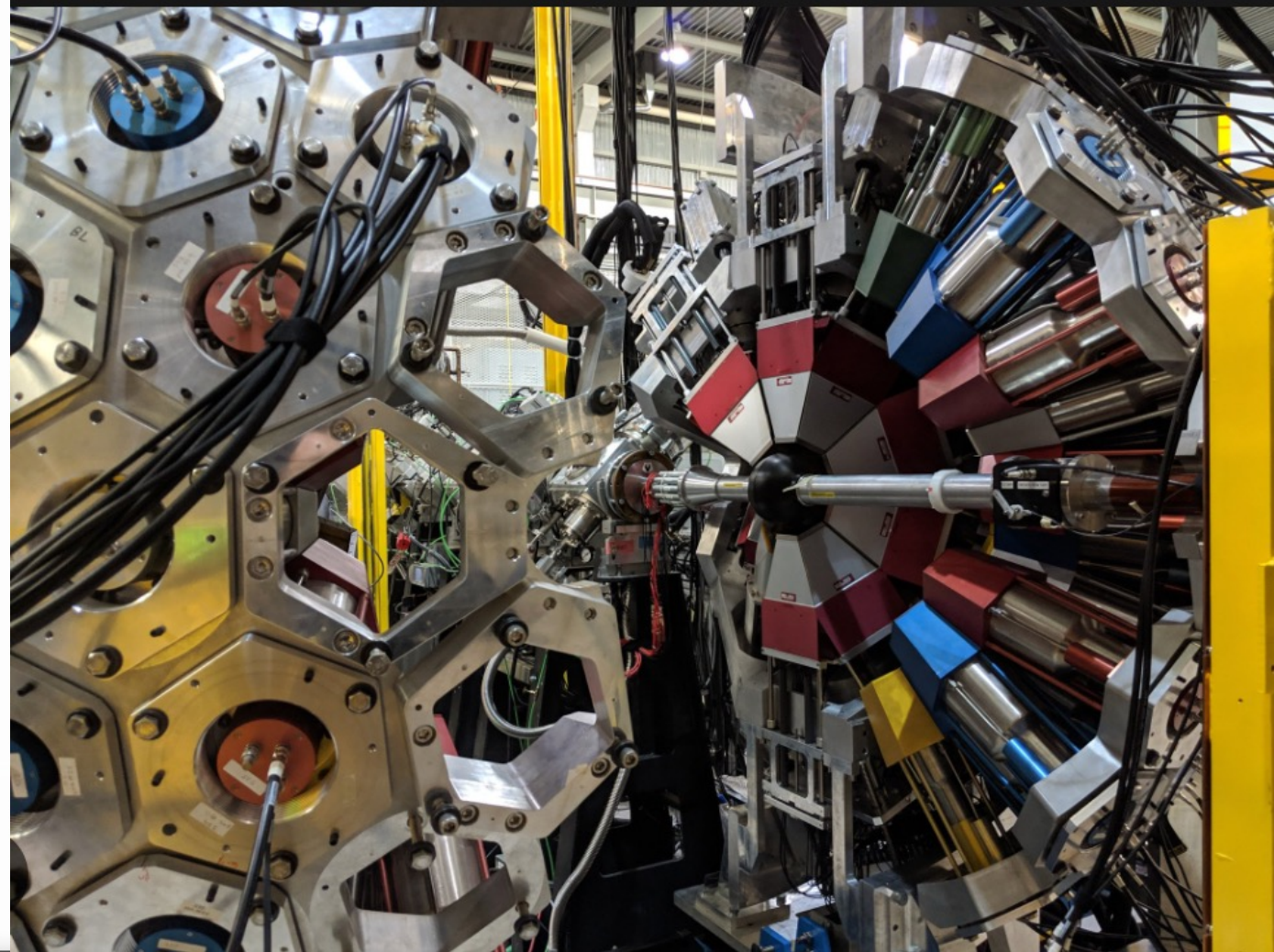
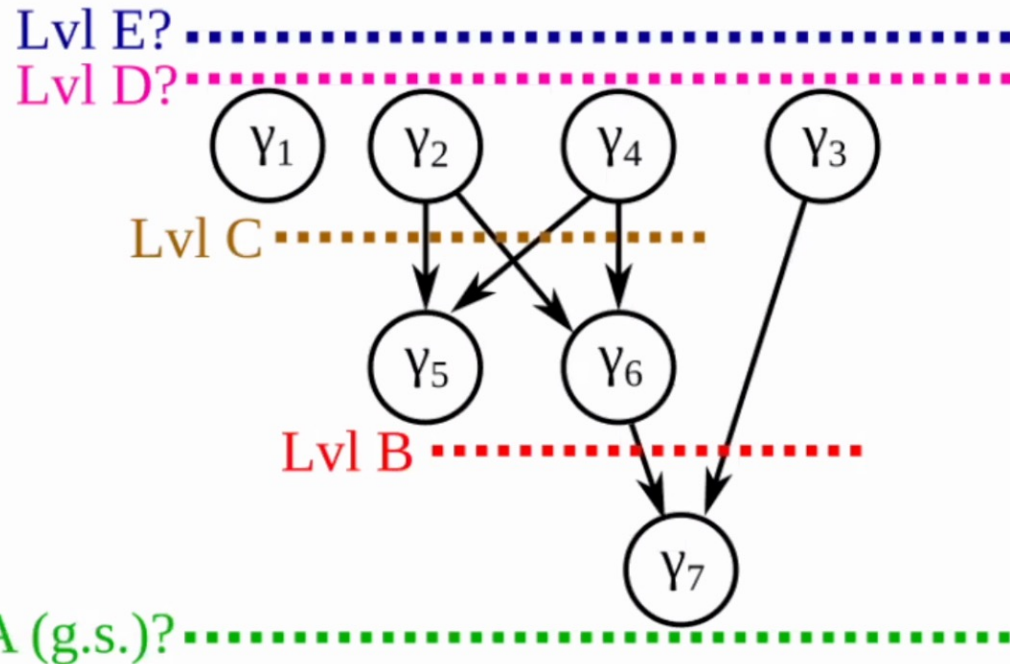

# Outline

- Define Objective:
  - Traditional decay-scheme generation
  - A novel approach using graph theory representation (G.Demand & P. E. Garrett, University of Guelph)
- Reformulating the Problem:
  - Generating matrix representation
  - Numerical optimization
- Reformulating the Solution:
  - Machine learning investigation
  - Quantum Algorithms

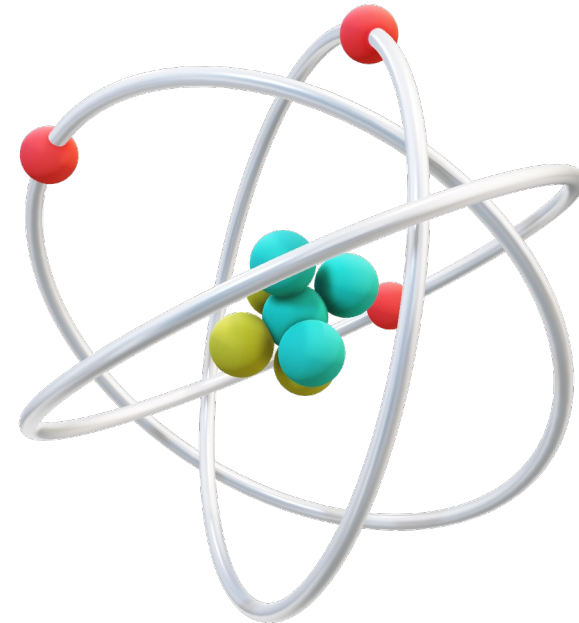

# Building a Nuclear Decay Scheme

Analysis is very time consuming!

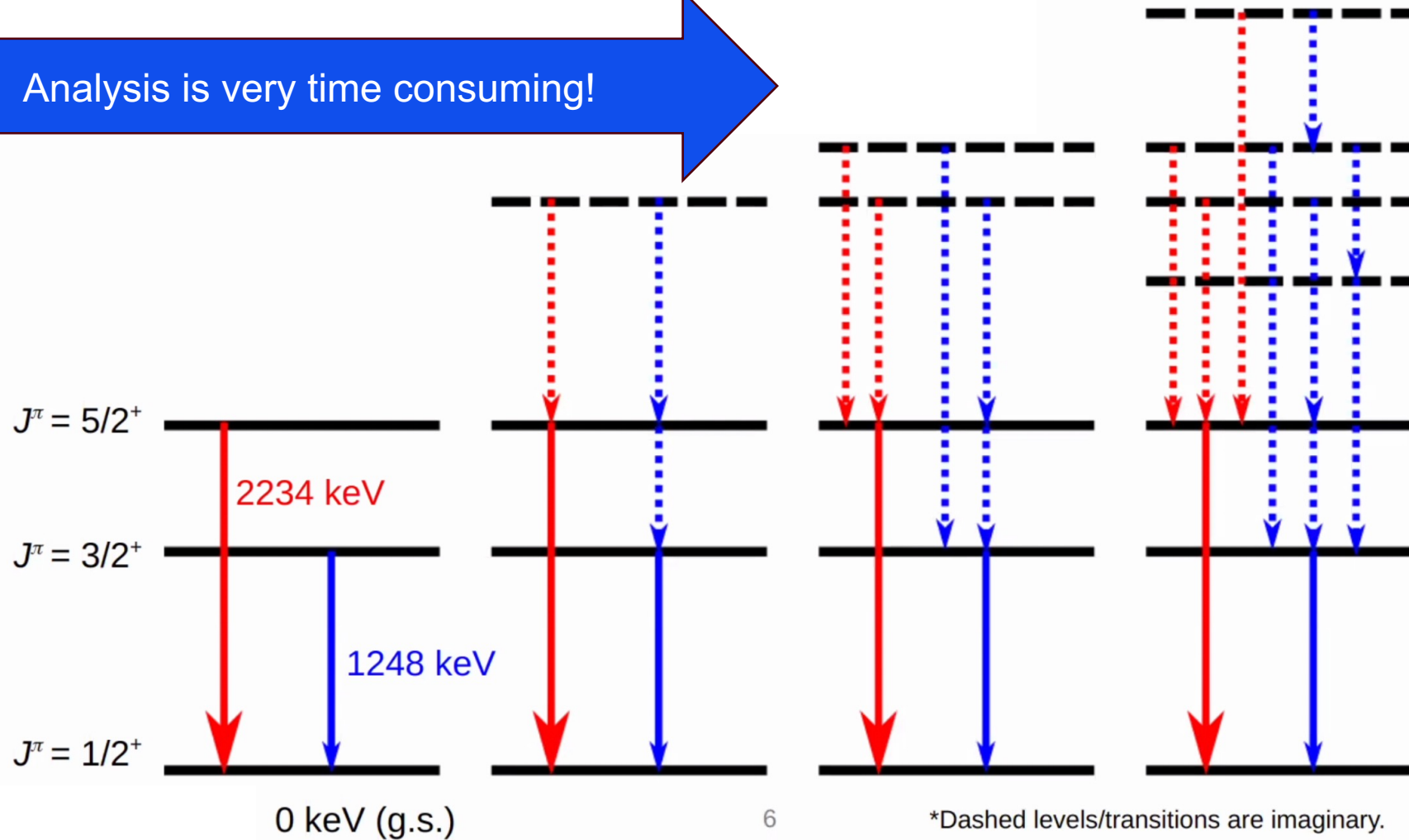

# 1D Gamma-Ray Singles Spectrum

- All statistics for  $n$  total  $\gamma$  transitions as measured by spectrometer
- The intensity of the  $i^{\text{th}}$   $\gamma$ -ray transition is stored as  $S_i$  in vector  $S$

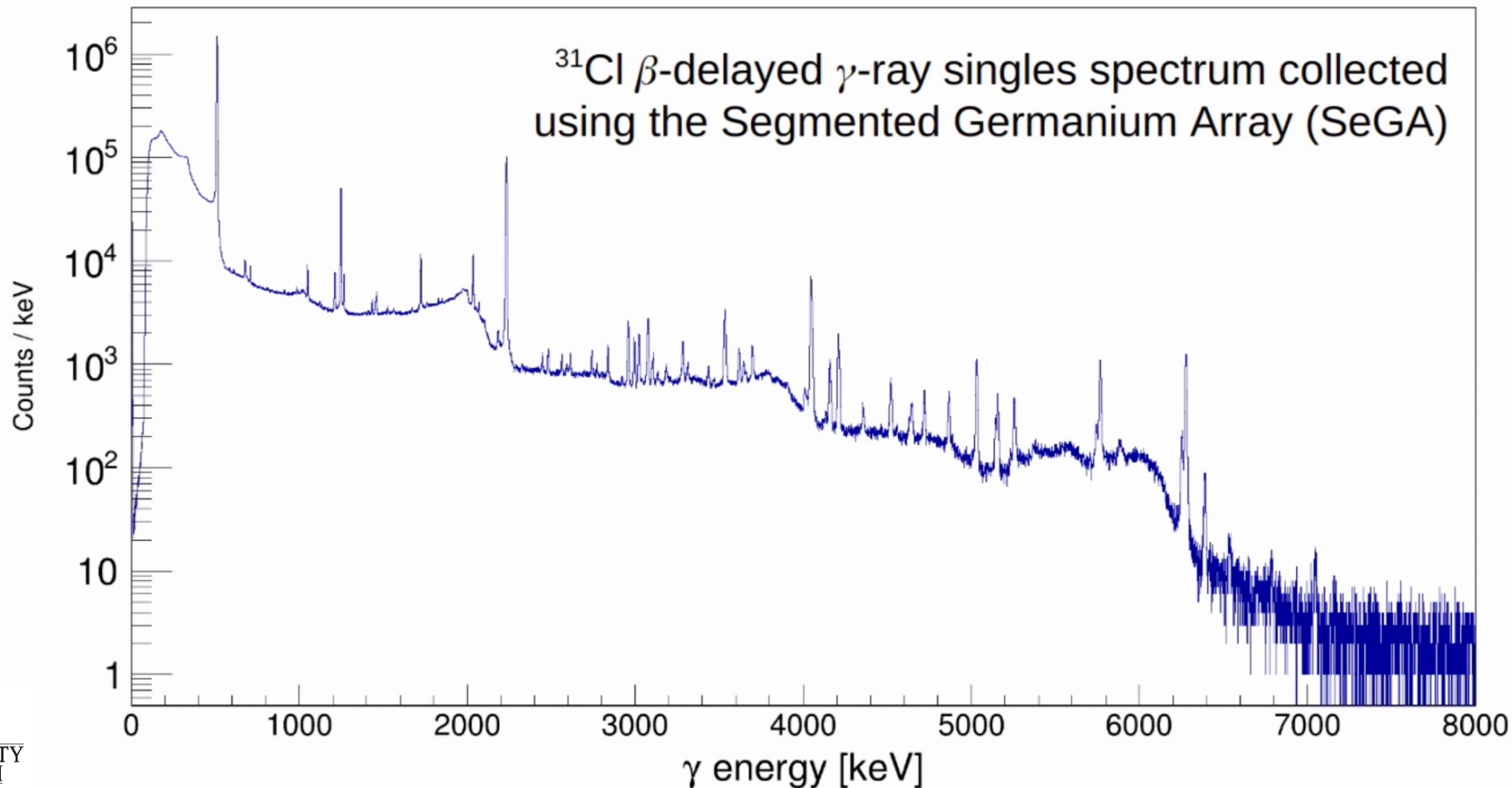

$$S = \begin{pmatrix} S_1 \\ S_2 \\ \vdots \\ S_n \end{pmatrix}$$

# 2D Gamma-Gamma Coincidence Matrix

- All gamma events detected in coincidence with other  $\gamma$ -rays
- The number of  $\gamma_i - \gamma_j$  coincidences is stored in each element  $C_{i,j}$  within the reduced coincidence matrix  $C$
- No temporal information; symmetry  $C_{i,j} = C_{j,i}$

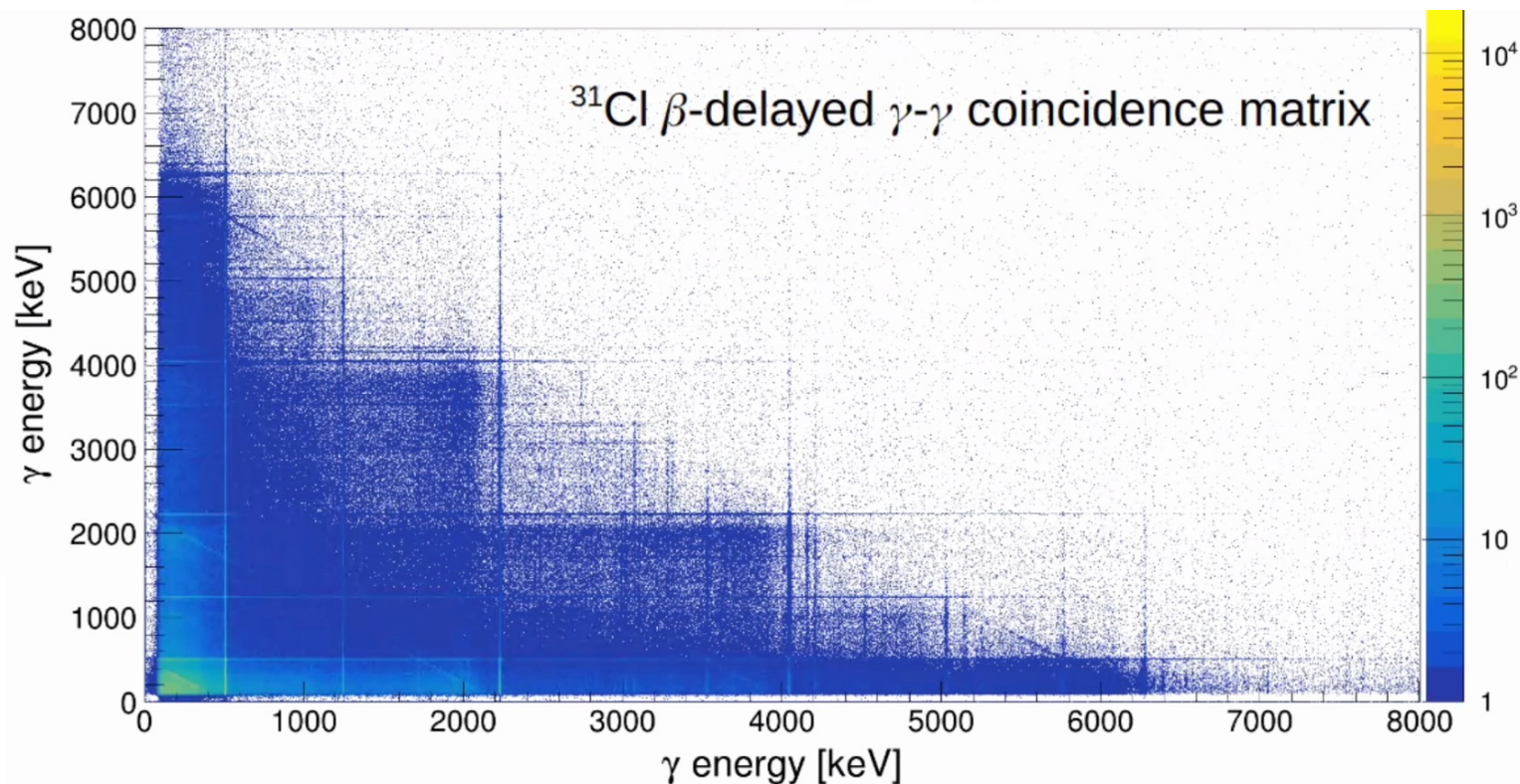

$$C = \begin{pmatrix} C_{11} & C_{12} & \cdots & C_{1n} \\ C_{21} & C_{22} & \cdots & C_{2n} \\ \vdots & \vdots & \cdots & \vdots \\ C_{n1} & C_{n2} & \cdots & C_{nn} \end{pmatrix}$$

# "Level-Centric" Decay Scheme

Decay schemes can be represented as graphs:

- Each level within the decay scheme corresponds to a vertex (or node), and the edges connecting these vertices correspond to  $\gamma$ -ray transitions between levels.
- Gamma-ray branching ratios correspond to edge weights.

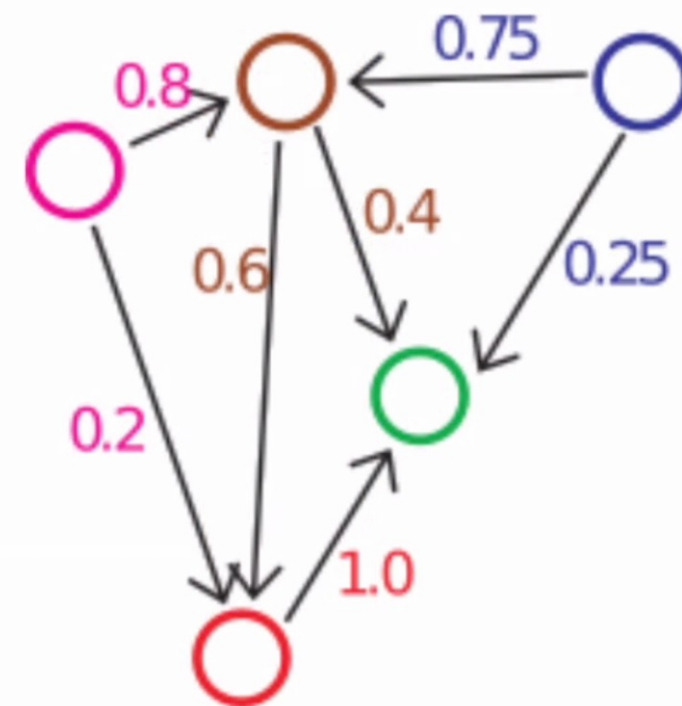
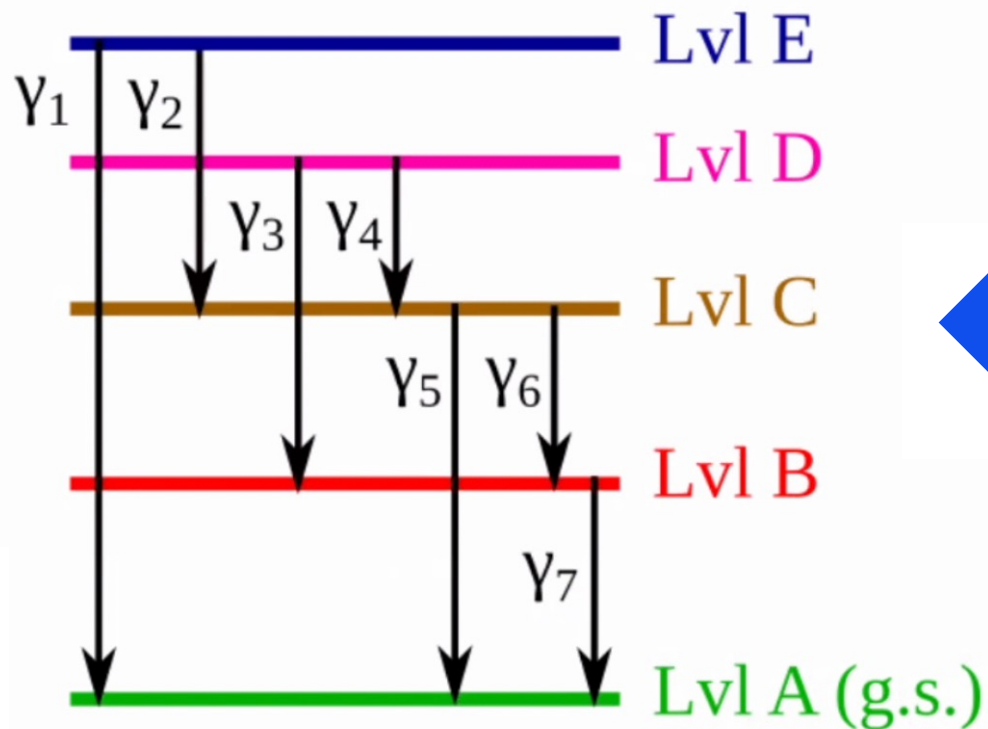

G. Demand, *Development of a Novel Algorithm for Nuclear Level Scheme Determination*. Master's thesis, University of Guelph, 2009.

# "Transition-Centric" Graph

Expressing Network in Terms of Statistical Observables:

- In this representation, vertices correspond to observable  $\gamma$ -rays, while edges connect  $\gamma$ -ray transitions detected in coincidence.
- A unique transition-centric graph exists for every level-centric decay scheme, but additional information required to reconstruct level-centric decay scheme from transition-centric graph.

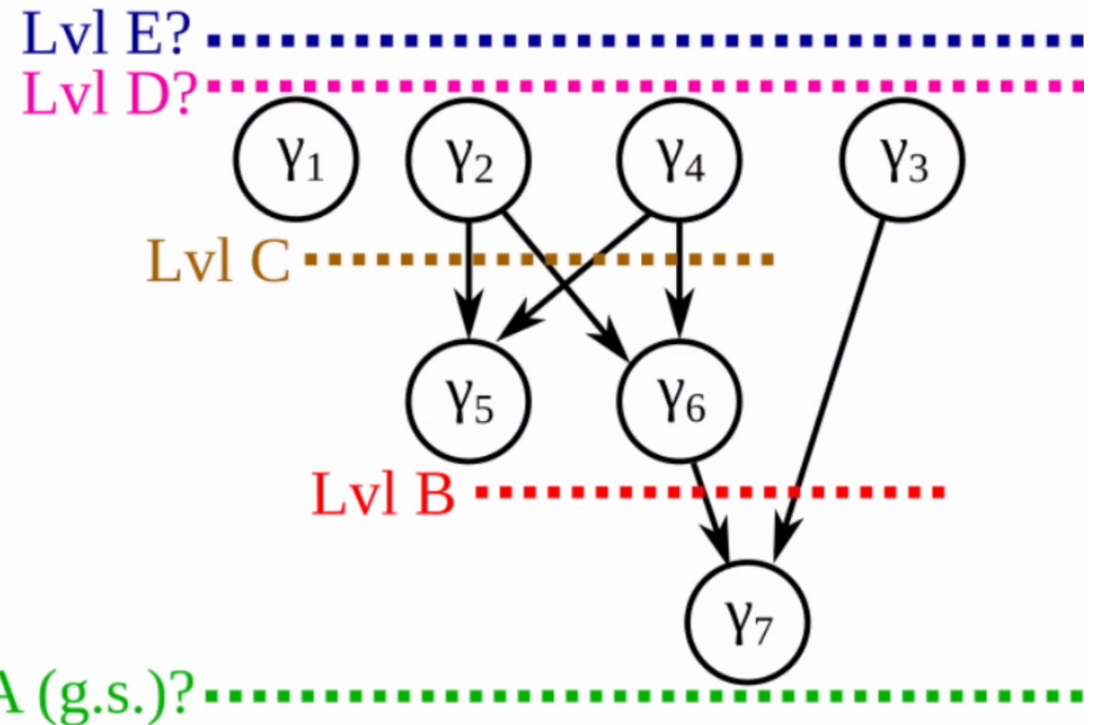
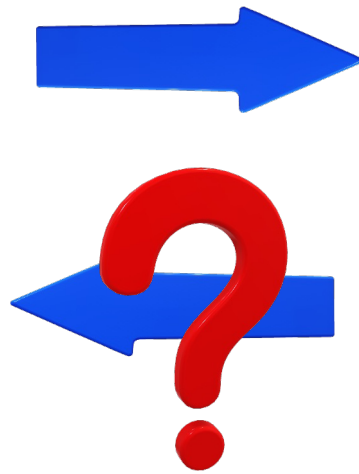
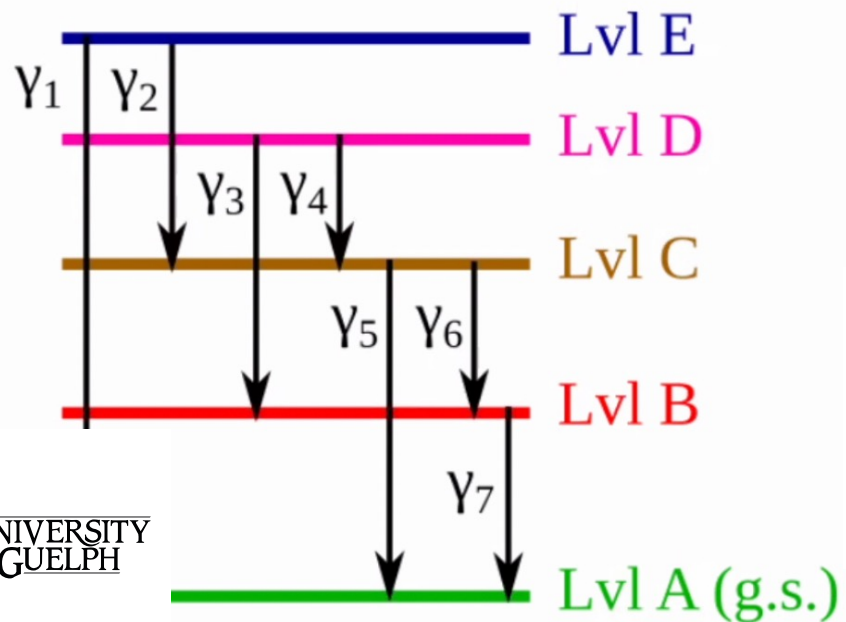

# Adjacency Matrix

Every weighted, directed graph has a unique adjacency matrix  $A$

Given a start position of vertex  $i$ , element  $A_{i,j}$  is the probability of transitioning directly to vertex  $j$  (non-zero numbers=branching ratios)

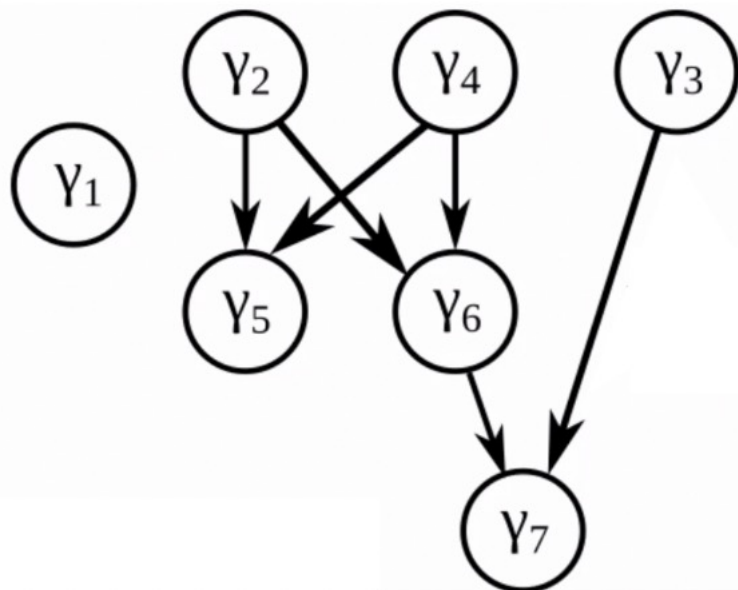

$$A = \begin{matrix} & \begin{matrix} Y_1 & Y_2 & Y_3 & Y_4 & Y_5 & Y_6 & Y_7 \end{matrix} \\ \begin{matrix} Y_1 \\ Y_2 \\ Y_3 \\ Y_4 \\ Y_5 \\ Y_6 \\ Y_7 \end{matrix} & \begin{pmatrix} 0 & 0 & 0 & 0 & 0 & 0 & 0 \\ 0 & 0 & 0 & 0 & 0.4 & 0.6 & 0 \\ 0 & 0 & 0 & 0 & 0 & 0 & 1.0 \\ 0 & 0 & 0 & 0 & 0.4 & 0.6 & 0 \\ 0 & 0 & 0 & 0 & 0 & 0 & 0 \\ 0 & 0 & 0 & 0 & 0 & 0 & 1.0 \\ 0 & 0 & 0 & 0 & 0 & 0 & 0 \end{pmatrix} \end{matrix}$$



# Equations to Solve for Optimization

Every weighted, directed graph has a unique adjacency matrix  $A$ .

- Adjacency matrix elements  $A_{i,j}$  give the probability of vertex  $i$  decaying directly to vertex  $j$  in a weighted, directed graph.
- Using matrix multiplication,  $A^2_{i,j}$  gives the probability of vertex  $i$  decaying to vertex  $j$  in exactly two steps.
- It can be proven via induction that the probability of decaying from vertex  $i$  to vertex  $j$  in  $n$  steps is given by  $A^n_{i,j}$
- Thus, the probability  $P$  of decaying from vertex  $i$  to vertex  $j$  in any number of steps is

$$P_{ij} = (A + A^2 + A^3 + \dots)_{ij}$$

- Using the identity  $I + A + A^2 + A^3 + \dots = (I - A)^{-1}$ , this implies

$$P = (I - A)^{-1} - I$$

# Equations to Solve for Optimization

Defining the Directed Coincidence Matrix  $D$ :

- The product of the observed  $\gamma$ -ray singles vector  $S_i$  with the probability  $P_{i,j}$  of  $\gamma_j$  decay occurring immediately after  $\gamma_i$  decay defines the (reduced) directed coincidence matrix:

$$D_{i,j} = SP_{i,j}$$

- Substituting our expression for probability in terms of the adjacency matrix:

$$D = S((I - A)^{-1} - I)$$

- The matrix sum of  $D$  and its transpose yields the observable, undirected coincidence matrix:

$$C = D + D^T$$

# Machine Learning Tools for Level-Scheme Design

Numerical Solution:

- Goal: Given  $S, C$ , find  $A, D$  such that

$$D = S \left( (I - A)^{-1} - I \right) \text{ and } C = D + D^T$$

- Therefore we have two governing equations:

$$\begin{aligned} D &= S \left( (I - A)^{-1} - I \right) \\ C &= D + D^T \end{aligned}$$

- Satisfying both equations leads to the nonlinear optimization problem:

$$\min_{A, D} \left\| D - S \left( (I - A)^{-1} - I \right) \right\|^2$$

subject to:  $A \geq 0, \sum_j A_{ij} \leq 1$   $C = D + D^T$  PHYSICS!

Enforce constraints such as conservation of energy, non-negative decay intensities, etc.

Finding  $A, D$  that produce the global minimum value is equivalent to finding  $A, D$  that satisfy the governing equations (and thus describe the true level scheme)



# Level-Scheme Reconstruction

Mathematical Formulation for Writing Level Scheme Construction as Matrix Equations

- Start with data from Gamma-Ray Spectroscopy experiment:
  - $S$ :  $\gamma$ -ray transitions & intensities (as diagonal matrix)
  - $C$ :  $\gamma\gamma$  coincidence data

- Following Demand (2013), try to satisfy two equations simultaneously:

$$D = S((I - A)^{-1} - I) \quad \text{and} \quad C = D + D^T$$

- Inverse optimization problem results in two matrices:
  - $A$ : the matrix of branching ratios between subsequent  $\gamma$ -rays
  - $D$ : the directed coincidence data
- Final Step: Create energy level scheme from matrix output

[	0.	0.	0.	0.	0.	0.	0.	0.	0.	0.]
[	4068.	0.	0.	0.	0.	0.	0.	0.	0.	0.]
[	0.	0.	0.	0.	0.	0.	0.	0.	0.	0.]
[	3563.05	3563.05	4809.95	0.	0.	0.	0.	0.	0.	0.]
[	0.	0.	0.	0.	0.	0.	0.	0.	0.	0.]
[	4229.02	4229.02	5708.98	0.	0.	0.	0.	0.	0.	0.]
[	0.	0.	0.	0.	0.	0.	0.	0.	0.	0.]
[	1731.1	1731.1	2336.9	4068.	0.	0.	0.	0.	0.	0.]
[	1486.44	1486.44	2006.62	0.	4097.94	3493.06	0.	0.	0.	0.]
[	0.	0.	0.	0.	0.	0.	0.	0.	0.	0.]

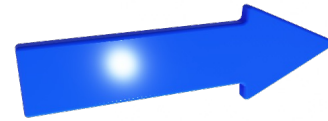
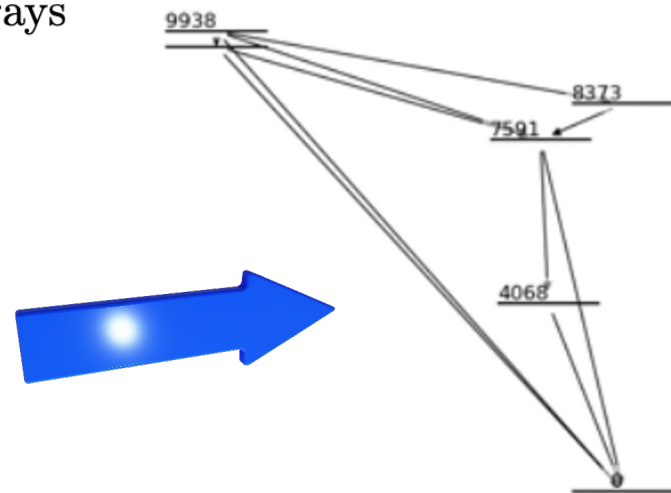

# Quantum Algorithm Augmentation

Quantum Approximate  
Optimization Algorithm

Quantum Annealing

Quantum Gradient Descent

All three approaches are aimed at optimization, they differ in their underlying principles, the types of problems they are suited for, and the techniques they employ. QAOA is a parameterized quantum circuit algorithm for combinatorial optimization, Quantum Annealing is a method for finding the ground state of a quantum system to solve optimization problems, and Quantum Gradient Descent is a quantum optimization algorithm inspired by classical gradient descent methods.

Thank you!

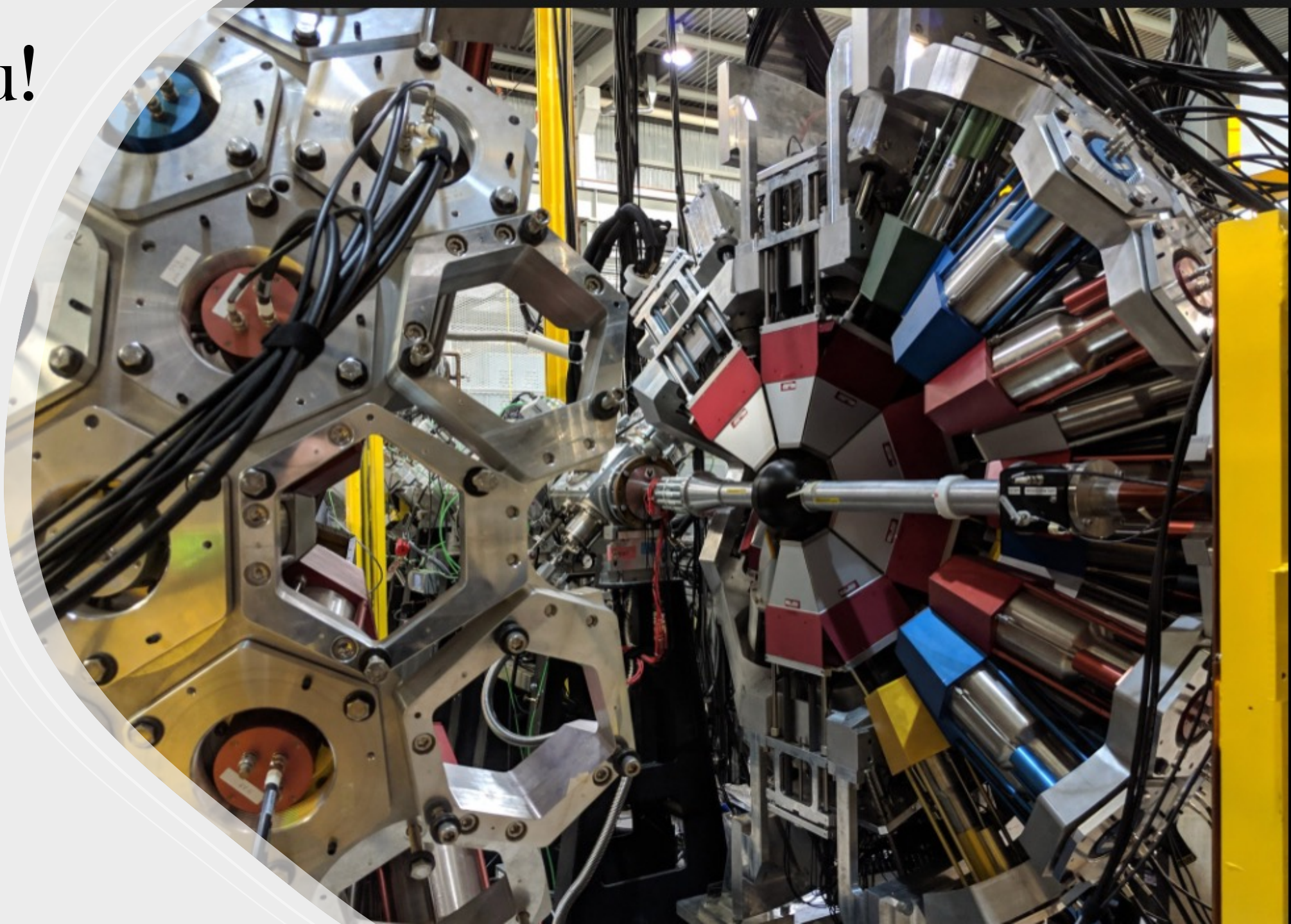

UNIVERSITY  
of GUELPH

Argonne  
NATIONAL LABORATORY

## **Quantum Annealing**

Quantum annealing is a quantum optimization technique that is inspired by the physical process of annealing, which is the gradual cooling of a material to reach its lowest energy state. Quantum annealing works by encoding the optimization problem into a Hamiltonian, which is a mathematical operator that describes the energy of a quantum system. The Hamiltonian has two terms: one that represents the objective function to be minimized, and one that induces quantum fluctuations. The algorithm starts with a high value of the quantum fluctuation term, which puts the system in a superposition of all possible states. Then, the algorithm gradually decreases the quantum fluctuation term and increases the objective function term, which drives the system towards the lowest energy state, which corresponds to the optimal solution.

Quantum annealing has been implemented on specialized hardware devices called quantum annealers, such as those developed by D-Wave Systems. Quantum annealers have thousands of qubits, which are the basic units of quantum information, and can solve large-scale optimization problems in seconds. However, quantum annealing also has some drawbacks, such as noise, decoherence, and limited connectivity between qubits. Moreover, quantum annealing is not guaranteed to find the global optimum, and may get stuck in local minima.

### **Quantum Approximate Optimization Algorithm (QAOA)**

QAOA is a quantum optimization algorithm that is based on the idea of variational quantum algorithms, which are hybrid algorithms that combine quantum and classical computation. QAOA works by encoding the optimization problem into a Hamiltonian, similar to quantum annealing. However, instead of gradually changing the Hamiltonian, QAOA applies a sequence of unitary operators to an initial state, which are parameterized by some angles. The unitary operators are chosen to alternate between the objective function term and the quantum fluctuation term. The algorithm then measures the final state and evaluates the objective function value. The algorithm repeats this process for different values of the angles, and uses a classical optimizer to find the optimal values that minimize the objective function. QAOA has some advantages over quantum annealing, such as being more robust to noise and decoherence, and being able to run on general-purpose quantum computers. However, QAOA also has some challenges, such as requiring many measurements and classical optimization steps, and having a trade-off between the quality of the solution and the depth of the circuit.



## **Quantum Gradient Descent**

Quantum gradient descent is another variational quantum algorithm that is inspired by the classical gradient descent method, which is one of the most widely used optimization techniques in machine learning. Quantum gradient descent works by encoding the optimization problem into a parametrized quantum circuit, which acts as an ansatz or a guess for the optimal state. The algorithm then measures the output of the circuit and evaluates the objective function value. The algorithm then computes the gradient of the objective function with respect to the parameters of the circuit, either analytically or numerically, and updates the parameters accordingly. The algorithm repeats this process until convergence or until a stopping criterion is met.

Quantum gradient descent has some benefits over classical gradient descent, such as being able to explore a larger space of possible solutions and being able to leverage quantum speedups for certain subroutines. However, quantum gradient descent also faces some difficulties, such as having high circuit complexity and measurement cost, and being sensitive to noise and barren plateaus.

# Transition-centric graph

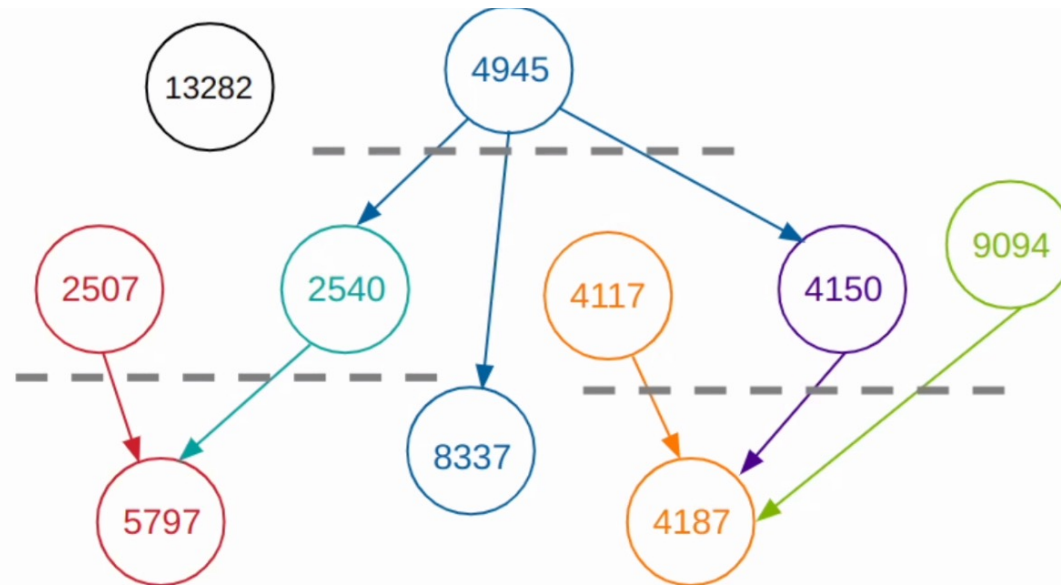

# Level-centric decay scheme

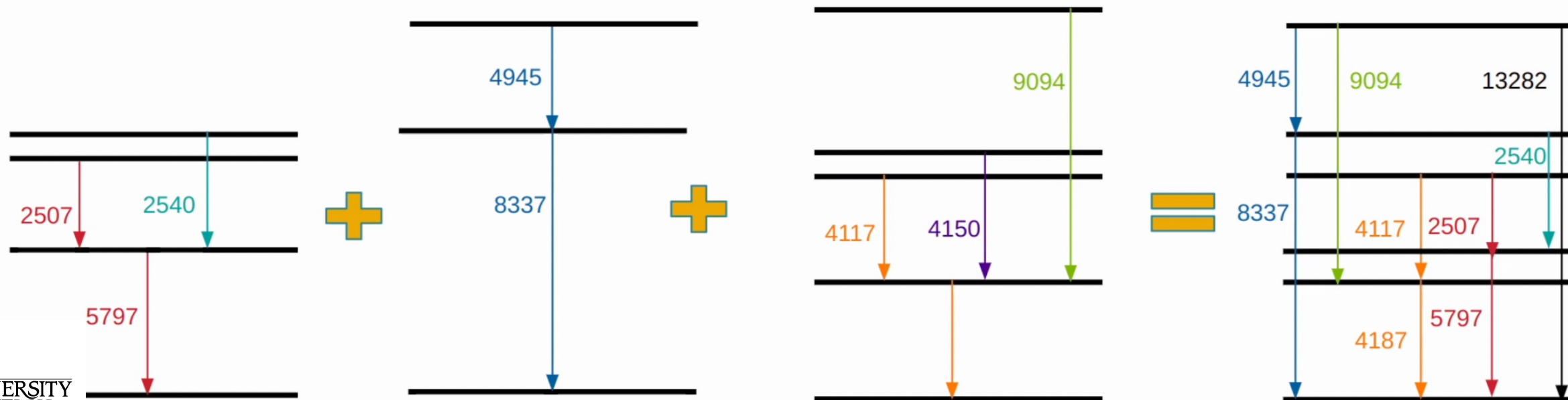

# Improvements in Optimization

## Not all Optimization Problems Created Equal

$$\min_{A,D} \|D - S((I - A)^{-1} - I)\|^2$$

subject to:

$$A \geq 0,$$

$$\sum_j A_{ij} \leq 1,$$

$$C = D + D^T$$



Calculating the inverse is far too computationally expensive

$$\min_{A,D} \|D - ST\|^2$$

subject to:

$$A \geq 0,$$

$$\sum_j A_{ij} \leq 1,$$

$$C = D + D^T$$

$$(I - A)(T + I) = I$$



Optimization rarely converges, search space is highly non-convex due to new constraint

$$\min_{X,A} \|(X \circ C)A + SA - (X \circ C)\|^2$$

subject to:

$$A \geq 0,$$

$$\sum_j A_{ij} \leq 1,$$

$$X_{ij} + X_{ji} = 1$$



Better! Still, optimization may fail to converge at times

Element-wise multiplication

Restructuring the mathematical optimization into an equivalent form drastically improves efficiency and reliability

# Benchmarking our Work

## Successful Outcomes

- Creates perfectly consistent decay scheme within 2 - 20 minutes (running on a laptop) for schemes with up to ~80 transitions

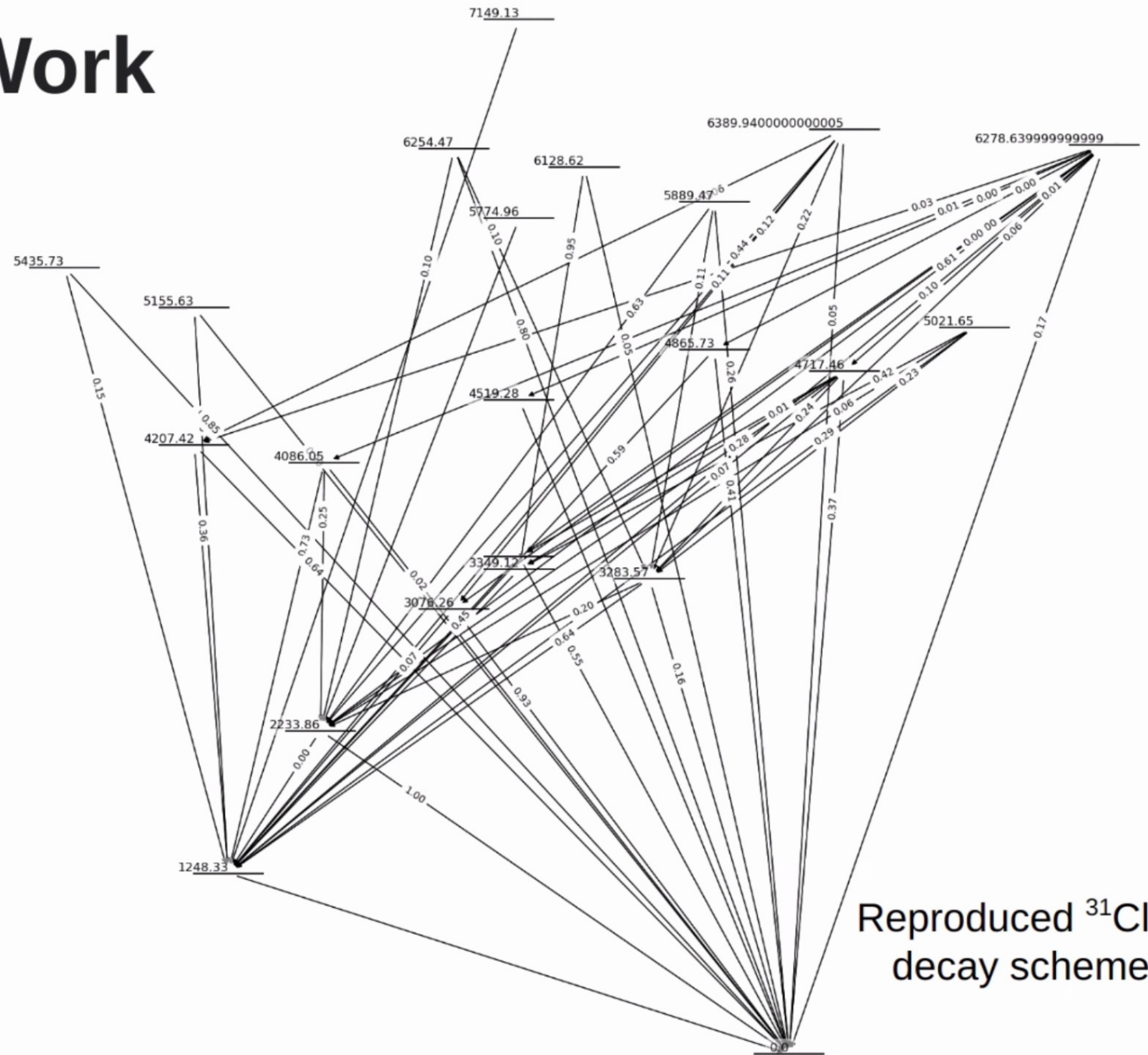

# Benchmarking our Work

## Potential Failures

1. Fails to converge on a solution within several hours; stop to check current “best guess”
  - Potential solution: parallelizing algorithm and utilize HPC resources
2. Converges to incorrect answer
  - Optimizer could converge to solution where function output is zero; if converges to solution but objective function is non-zero, decay scheme must be incorrect
  - Borderline cases where solution is an easy fix, i.e. a few misplaced, weak transitions

## Potential Solutions

- Using prior information about decay scheme to constrain elements of adjacency matrix  $A$  to reduce parameter space in numerical optimization

# Determining Elements of S, C Matrices

## Software Tools in Production

- Peak identification algorithm
- Automated peak fitter
- Background subtraction

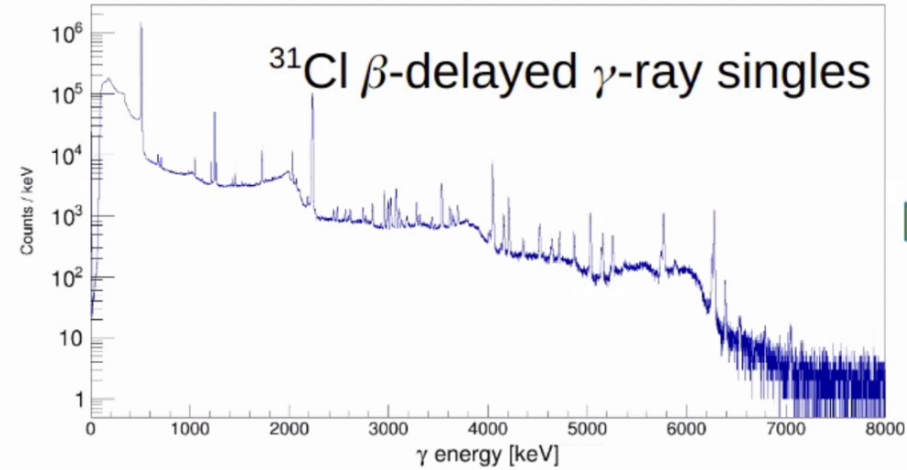

$$S = \begin{pmatrix} S_1 \\ S_2 \\ \dots \\ S_n \end{pmatrix}$$

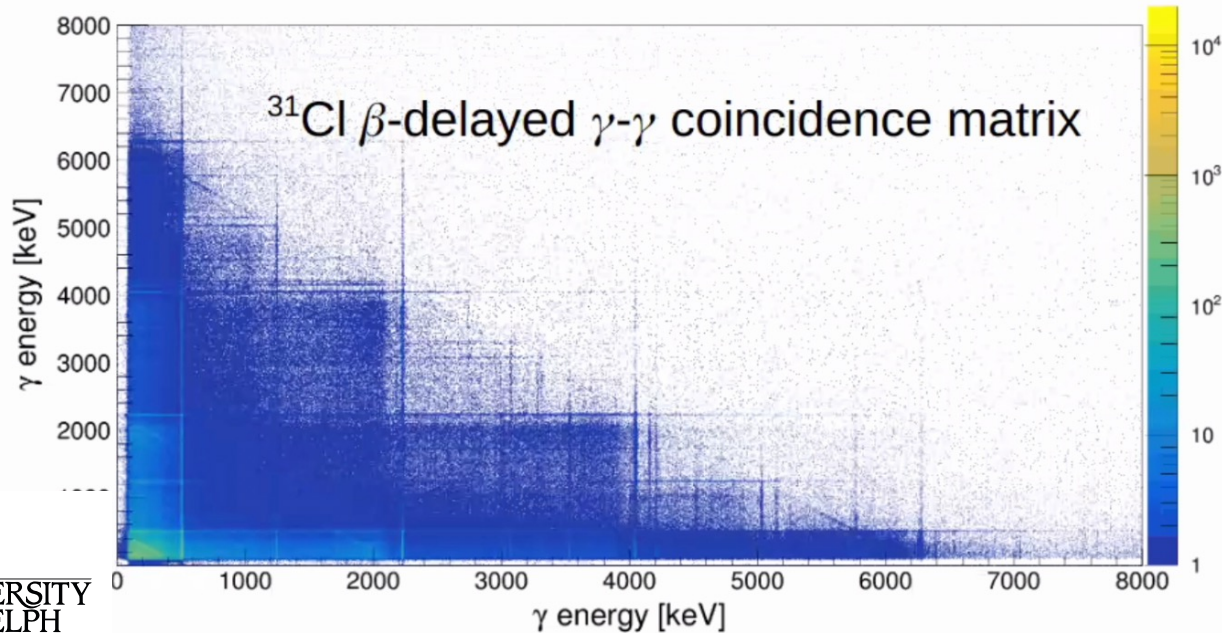

$$C = \begin{pmatrix} 0 & C_{i,j} & \dots & C_{i,j} \\ C_{i,j} & 0 & & \vdots \\ \vdots & & 0 & \ddots \\ C_{i,j} & \dots & \ddots & 0 \end{pmatrix}$$



# Introduction text slide here

Lorem ipsum dolor sit amet, consectetur adipiscing elit. Maecenas porttitor congue massa. Fusce posuere, magna sed pulvinar ultricies, purus lectus malesuada libero, sit amet commodo magna eros quis urna.

Lorem ipsum dolor sit amet, consectetur adipiscing elit. Maecenas porttitor congue massa. Fusce posuere, magna sed pulvinar ultricies, purus lectus malesuada libero, sit amet commodo magna eros quis urna.



# A great title in here.

---

Lorem ipsum dolor sit amet, consectetur adipiscing elit. Maecenas  
porttitor congue massa

# A great title in here.



Lorem ipsum dolor sit amet, consectetur adipiscing elit. Maecenas  
porttitor congue massa

# A great title in here.

---

Lorem ipsum dolor sit amet, consectetur adipiscing elit. Maecenas porttitor congue massa

# Simple text slide.

Lorem ipsum dolor sit amet, consectetur adipiscing elit. Ut vitae diam commodo, efficitur nisl sit amet, viverra mi. Nunc fringilla tristique suscipit. Nam sed nisi suscipit, vulputate tortor ut, condimentum mi. Curabitur viverra enim at urna congue lobortis. Cras volutpat urna eget eros sollicitudin, et placerat risus interdum. In nec tortor rhoncus, venenatis nulla id, gravida ante.

Vivamus consectetur condimentum lacus sit amet rutrum. Nam pharetra libero erat, ac suscipit neque faucibus sit amet. Vivamus eu odio nec sem consectetur accumsan in eget sem. Donec gravida est vel ex interdum consequat. Proin dolor erat, vehicula ac orci et, pulvinar vestibulum mauris. Phasellus congue libero nisl, non mattis dolor auctor et. Pellentesque scelerisque, nisi sed viverra feugiat, lacus leo mattis nisl, eget venenatis nisi arcu sit amet nibh.

# Simple text slide.

Lorem ipsum dolor sit amet, consectetur adipiscing elit. Ut vitae diam commodo, efficitur nisl sit amet, viverra mi. Nunc fringilla tristique suscipit. Nam sed nisi suscipit, vulputate tortor ut, condimentum mi. Curabitur viverra enim at urna congue lobortis. Cras volutpat urna eget eros sollicitudin, et placerat risus interdum. In nec tortor rhoncus, venenatis nulla id, gravida ante.

Vivamus consectetur condimentum lacus sit amet rutrum. Nam pharetra libero erat, ac suscipit neque faucibus sit amet. Vivamus eu odio nec sem consectetur accumsan in eget sem. Donec gravida est vel ex interdum consequat. Proin dolor erat, vehicula ac orci et, pulvinar vestibulum mauris. Phasellus congue libero nisl, non mattis dolor auctor et. Pellentesque scelerisque, nisi sed viverra feugiat, lacus leo mattis nisl, eget venenatis nisi arcu sit amet nibh.

# Simple text slide.

Lorem ipsum dolor sit amet, consectetur adipiscing elit. Maecenas porttitor congue massa. Fusce posuere, magna sed pulvinar ultricies, purus lectus malesuada libero, sit amet commodo magna eros quis urna.

Nunc viverra imperdiet enim. Fusce est. Vivamus a tellus.

Pellentesque habitant morbi tristique senectus et netus et malesuada fames ac turpis egestas. Proin pharetra nonummy pede. Mauris et orci.

Lorem ipsum dolor sit amet, consectetur adipiscing elit. Maecenas porttitor congue massa. Fusce posuere, magna sed pulvinar ultricies, purus lectus malesuada libero, sit amet commodo magna eros quis urna.

Nunc viverra imperdiet enim. Fusce est. Vivamus a tellus.

Pellentesque habitant morbi tristique senectus et netus et malesuada fames ac turpis egestas. Proin pharetra nonummy pede. Mauris et orci.

# Simple text slide.

Lorem ipsum dolor sit amet, consectetur adipiscing elit. Maecenas porttitor congue massa. Fusce posuere, magna sed pulvinar ultricies, purus lectus malesuada libero, sit amet commodo magna eros quis urna.

Nunc viverra imperdiet enim. Fusce est. Vivamus a tellus.

Pellentesque habitant morbi tristique senectus et netus et malesuada fames ac turpis egestas. Proin pharetra nonummy pede. Mauris et orci.

Lorem ipsum dolor sit amet, consectetur adipiscing elit. Maecenas porttitor congue massa. Fusce posuere, magna sed pulvinar ultricies, purus lectus malesuada libero, sit amet commodo magna eros quis urna.

Nunc viverra imperdiet enim. Fusce est. Vivamus a tellus.

Pellentesque habitant morbi tristique senectus et netus et malesuada fames ac turpis egestas. Proin pharetra nonummy pede. Mauris et orci.

# Content

01	Page title
02	Page title
03	Page title
04	Page title
05	Page title
06	Page title



# Content

01	Page title
02	Page title
03	Page title
04	Page title
05	Page title
06	Page title

# TITLE OF DATA

—

The data information goes here

**12**

DATA POINT

**165**

DATA POINT

**10**

DATA POINT

**345**

DATA POINT

# TITLE OF DATA

—

The data information goes here

**12**

DATA POINT

**165**

DATA POINT

**10**

DATA POINT

**345**

DATA POINT

# Achievements



The data information goes here

12

DATA POINT

165

DATA POINT

10

DATA POINT

345

DATA POINT

text

# A Title here.

—

Lorem ipsum dolor sit amet, consectetur adipiscing elit. Maecenas porttitor congue massa. Fusce posuere, magna sed pulvinar ultricies, purus lectus malesuada libero, sit amet commodo magna eros quis urna.

Nunc viverra imperdiet enim. Fusce est. Vivamus a tellus.

Pellentesque habitant morbi tristique senectus et netus et malesuada fames ac turpis egestas. Proin pharetra nonummy pede. Mauris et orci.

## Sub Title Here

Lorem ipsum dolor sit amet, consectetur adipiscing elit. Ut vitae diam commodo, efficitur nisl sit amet, viverra mi. Nunc fringilla tristique suscipit. Nam sed nisi suscipit, vulputate tortor ut, condimentum mi.

Vivamus consectetur condimentum lacus sit amet rutrum. Nam pharetra libero erat, ac suscipit neque faucibus sit amet. Vivamus eu odio nec sem consectetur accumsan in eget sem. Donec gravida est vel ex.

text

# A Title here.

---

Lorem ipsum dolor sit amet, consectetur adipiscing elit. Maecenas porttitor congue massa. Fusce posuere, magna sed pulvinar ultricies, purus lectus malesuada libero, sit amet commodo magna eros quis urna.

Nunc viverra imperdiet enim. Fusce est. Vivamus a tellus.

Pellentesque habitant morbi tristique senectus et netus et malesuada fames ac turpis egestas. Proin pharetra nonummy pede. Mauris et orci.

## Sub Title Here

Lorem ipsum dolor sit amet, consectetur adipiscing elit. Ut vitae diam commodo, efficitur nisl sit amet, viverra mi. Nunc fringilla tristique suscipit. Nam sed nisi suscipit, vulputate tortor ut, condimentum mi.

Vivamus consectetur condimentum lacus sit amet rutrum. Nam pharetra libero erat, ac suscipit neque faucibus sit amet. Vivamus eu odio nec sem consectetur accumsan in eget sem. Donec gravida est vel ex.

# Achievements

A description of the items below



## Option One

Lorem ipsum dolor sit amet, consectetur adipiscing elit. Maecenas porttitor congue massa.



## Option Three

Lorem ipsum dolor sit amet, consectetur adipiscing elit. Maecenas porttitor congue massa.



## Option Two

Lorem ipsum dolor sit amet, consectetur adipiscing elit. Maecenas porttitor congue massa.



## Option Four

Lorem ipsum dolor sit amet, consectetur adipiscing elit. Maecenas porttitor congue massa.

Option One

Option Two

Option Three

Option Four

This is  
a great  
slide.

**Title here**

—  
Lorem ipsum dolor sit  
amet, consectetur  
adipiscing elit.  
Maecenas porttitor  
congue massa.

**Title here**

—  
Lorem ipsum dolor sit  
amet, consectetur  
adipiscing elit.  
Maecenas porttitor  
congue massa.



Option One

Option Two

Option Three

Option Four

This is  
a great  
slide.

**Title here**

—  
Lorem ipsum dolor sit  
amet, consectetur  
adipiscing elit.  
Maecenas porttitor  
congue massa.

**Title here**

—  
Lorem ipsum dolor sit  
amet, consectetur  
adipiscing elit.  
Maecenas porttitor  
congue massa.

# Break Slide.

—

Lorem ipsum dolor sit amet, consectetur adipiscing elit. Maecenas porttitor congue massa. Fusce posuere, magna sed pulvinar ultricies, purus lectus malesuada libero, sit amet commodo magna eros quis urna.

# Break Slide.



Lorem ipsum dolor sit amet, consectetur adipiscing elit. Maecenas porttitor congue massa. Fusce posuere, magna sed pulvinar ultricies, purus lectus malesuada libero, sit amet commodo magna eros quis urna.

# Break Slide.

---

Lorem ipsum dolor sit amet, consectetur adipiscing elit. Maecenas porttitor congue massa. Fusce posuere, magna sed pulvinar ultricies, purus lectus malesuada libero, sit amet commodo magna eros quis urna.

# Break Slide.

—

Lorem ipsum dolor sit amet, consectetur adipiscing elit. Maecenas porttitor congue massa. Fusce posuere, magna sed pulvinar ultricies, purus lectus malesuada libero, sit amet commodo magna eros quis urna.

# Visuals

Fusce posuere, magna sed pulvinar  
ultrices, purus lectus malesuada  
libero, sit amet commodo magna eros  
quis urna.

# Timeline

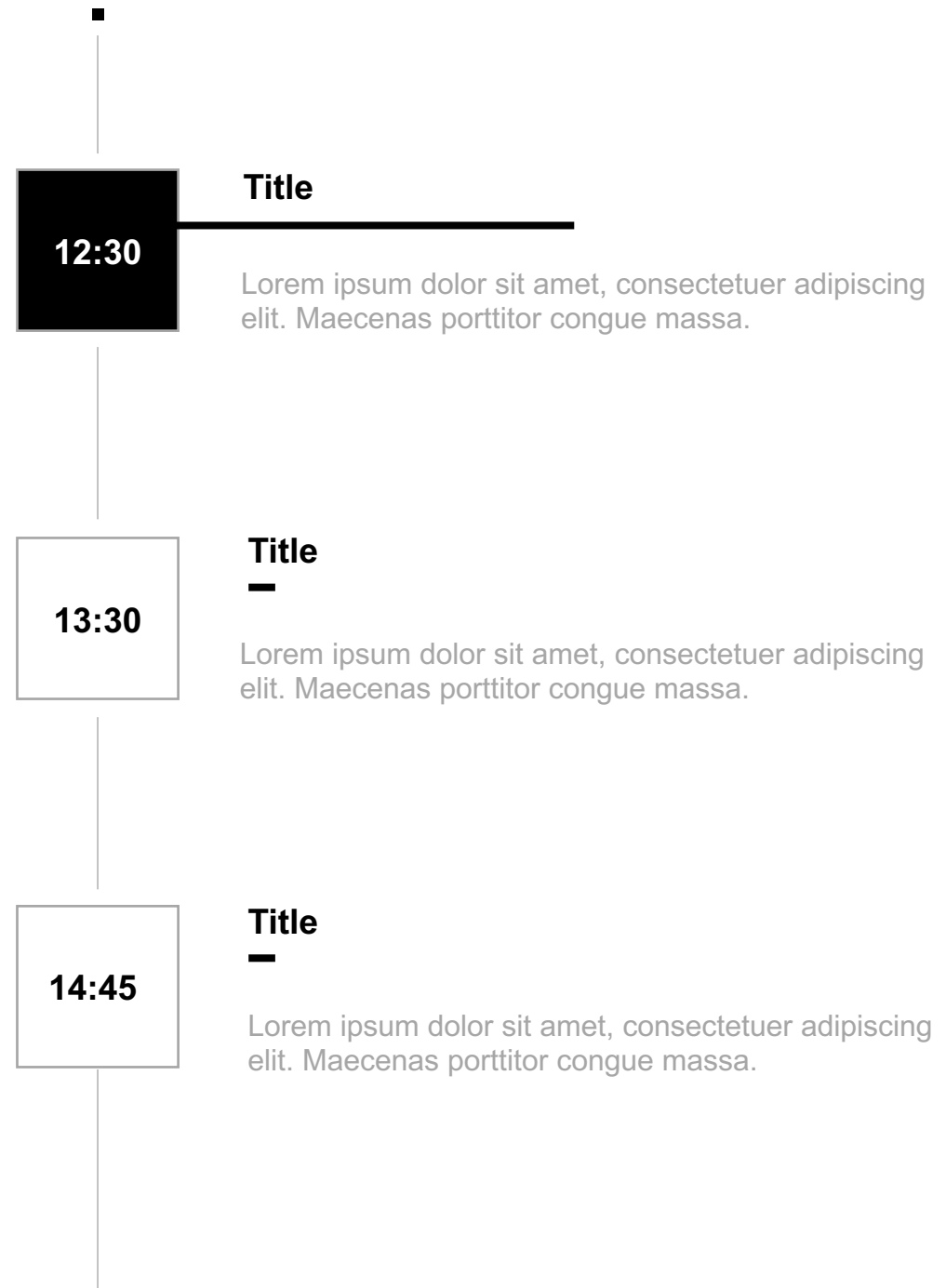

15:50

**Title**  
—

Lorem ipsum dolor sit amet, consectetur adipiscing elit. Maecenas porttitor congue massa.

14:45

**Title**  
—

Lorem ipsum dolor sit amet, consectetur adipiscing elit. Maecenas porttitor congue massa.

17:05

**Title**  
—

Lorem ipsum dolor sit amet, consectetur adipiscing elit. Maecenas porttitor congue massa.





# Timeline



15:50

**Title**

—  
Lorem ipsum dolor sit amet, consectetur adipiscing elit. Maecenas porttitor congue massa.

14:45

**Title**

—  
Lorem ipsum dolor sit amet, consectetur adipiscing elit. Maecenas porttitor congue massa.

17:05

**Title**

—  
Lorem ipsum dolor sit amet, consectetur adipiscing elit. Maecenas porttitor congue massa.



# Title Here



Some text describing timeline or options

1

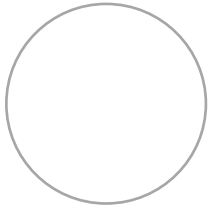

**One**



Lorem ipsum dolor sit  
amet, consectetur  
adipiscing elit.  
Maecenas porttitor  
congue massa.

2

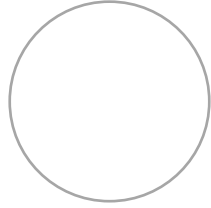

**Two**



Lorem ipsum dolor sit  
amet, consectetur  
adipiscing elit.  
Maecenas porttitor  
congue massa.

3

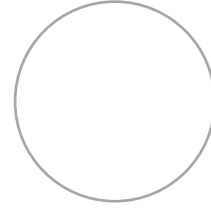

**Three**



Lorem ipsum dolor sit  
amet, consectetur  
adipiscing elit.  
Maecenas porttitor  
congue massa.

4

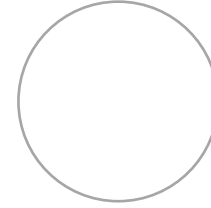

**Four**



Lorem ipsum dolor sit  
amet, consectetur  
adipiscing elit.  
Maecenas porttitor  
congue massa.

## 01. Title Here

—

Lorem ipsum dolor sit amet, consectetur adipiscing elit. Maecenas porttitor congue massa.

## 02. Title Here

—

Lorem ipsum dolor sit amet, consectetur adipiscing elit. Maecenas porttitor congue massa.

## 03. Title Here

—

Lorem ipsum dolor sit amet, consectetur adipiscing elit. Maecenas porttitor congue massa.

## 01. Title Here

---

Lorem ipsum dolor sit amet, consectetur adipiscing elit. Maecenas porttitor congue massa.

## 02. Title Here

---

Lorem ipsum dolor sit amet, consectetur adipiscing elit. Maecenas porttitor congue massa.

## 03. Title Here

---

Lorem ipsum dolor sit amet, consectetur adipiscing elit. Maecenas porttitor congue massa.

# Title.

Fusce posuere, magna sed pulvinar ultricies, purus lectus malesuada.

# Title.

Fusce posuere, magna sed pulvinar ultricies, purus lectus malesuada.

# Title.

Fusce posuere, magna sed pulvinar ultricies, purus lectus malesuada.



# Chart Example

Description of chart goes here

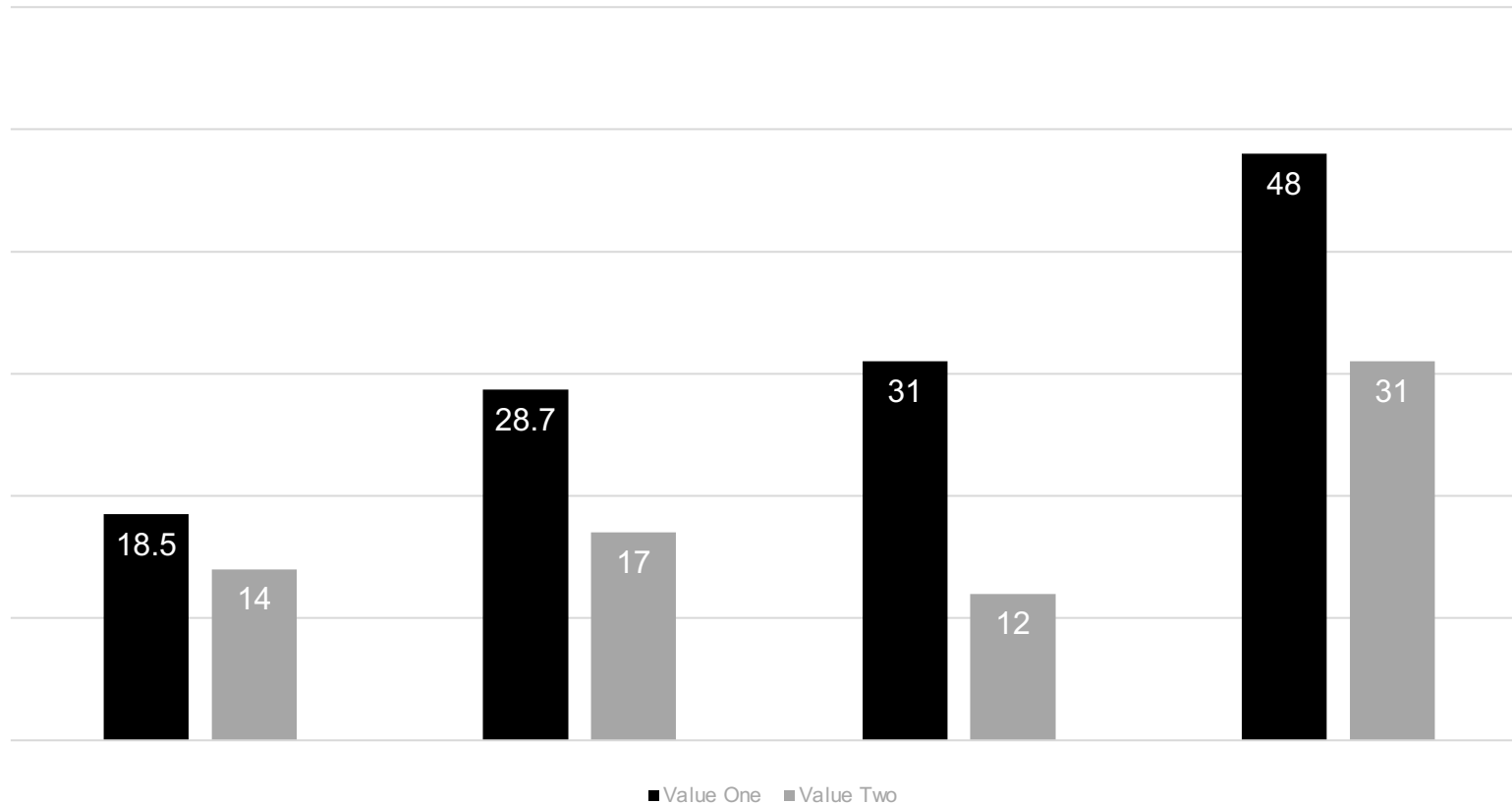

## 01. Value Black

Lorem ipsum dolor sit amet, consectetur adipiscing elit. Maecenas porttitor congue massa.

## 02. Value grey

Lorem ipsum dolor sit amet, consectetur adipiscing elit. Maecenas porttitor congue massa.

# Chart Example

Description of chart goes here

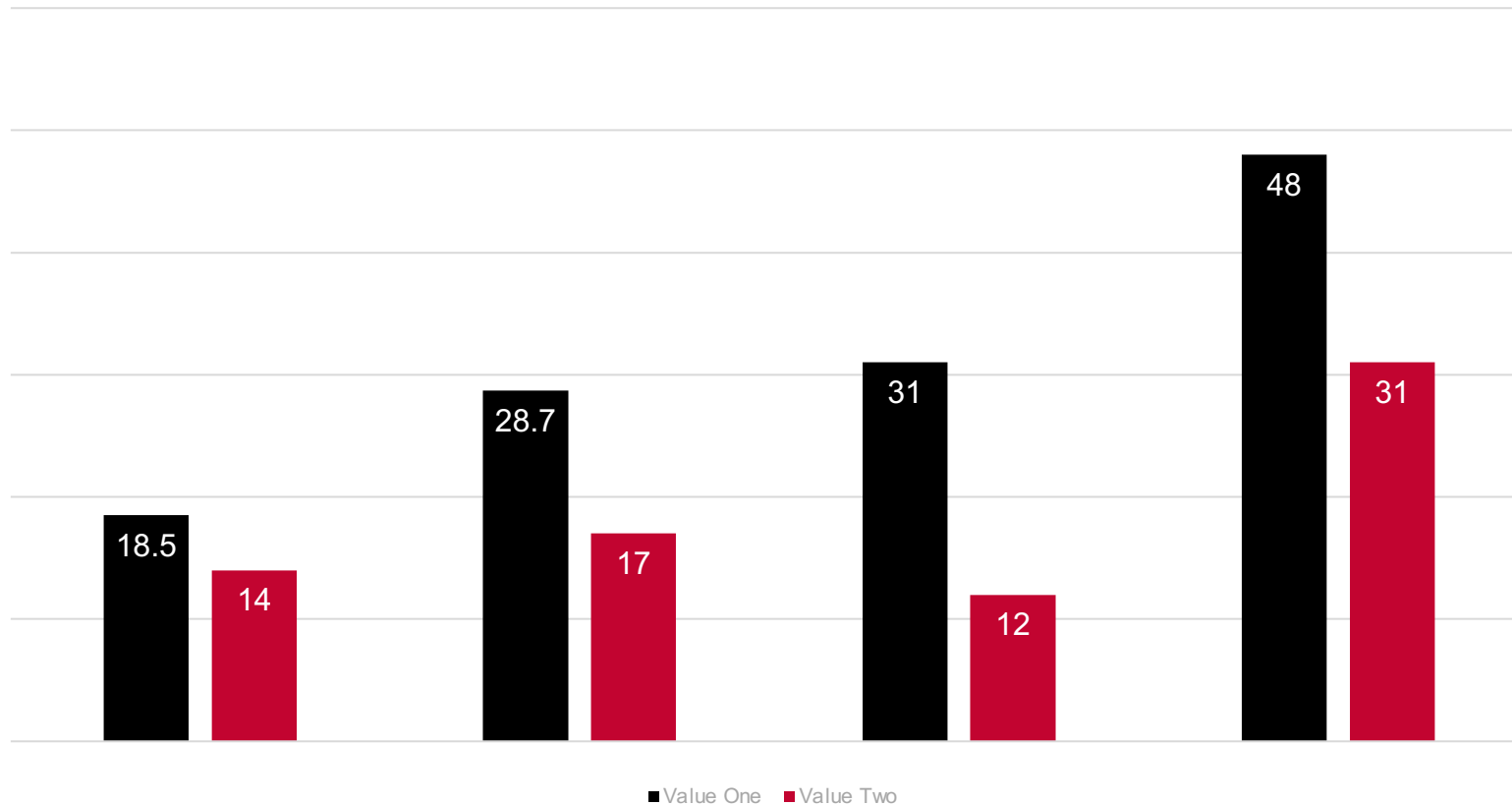

## 01. Value Black

Lorem ipsum dolor sit amet, consectetur adipiscing elit. Maecenas porttitor congue massa.

## 02. Value red

Lorem ipsum dolor sit amet, consectetur adipiscing elit. Maecenas porttitor congue massa.

# Example line chart

—

Lorem ipsum dolor sit amet, consectetur adipiscing elit. Maecenas porttitor congue massa. Fusce posuere, magna sed pulvinar ultricies, purus lectus malesuada libero, sit amet commodo magna eros quis urna.

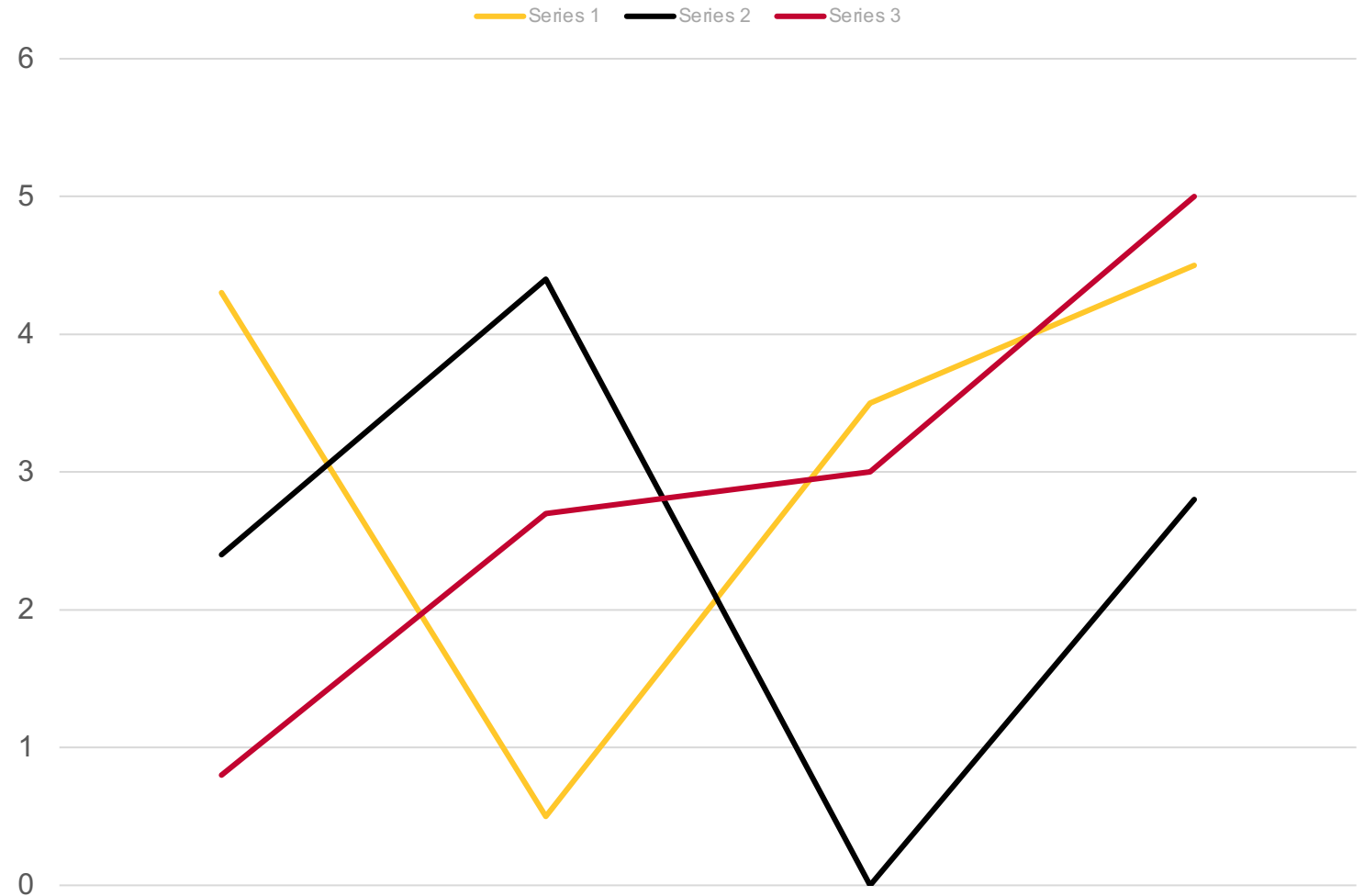

# Bar chart.

—

Lorem ipsum dolor sit amet, consectetur adipiscing elit. Maecenas porttitor congue massa. Fusce posuere, magna sed pulvinar ultricies, purus lectus malesuada libero, sit amet commodo magna eros quis urna.

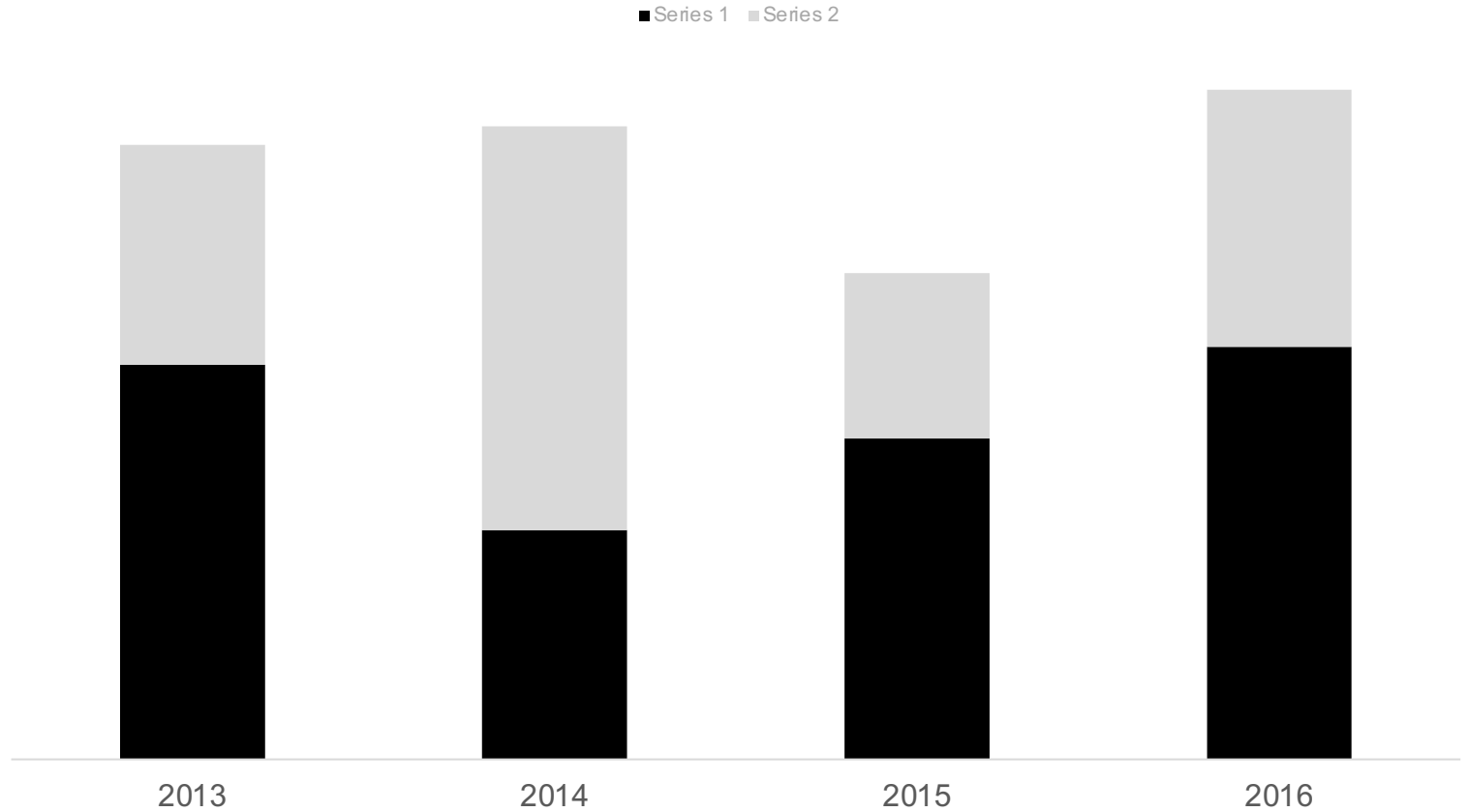

# Bar chart.

—  
Lorem ipsum dolor sit amet,  
consectetur adipiscing elit.  
Maecenas porttitor congue massa.  
Fusce posuere, magna sed pulvinar  
ultrices, purus lectus malesuada  
libero, sit amet commodo magna eros  
quis urna.

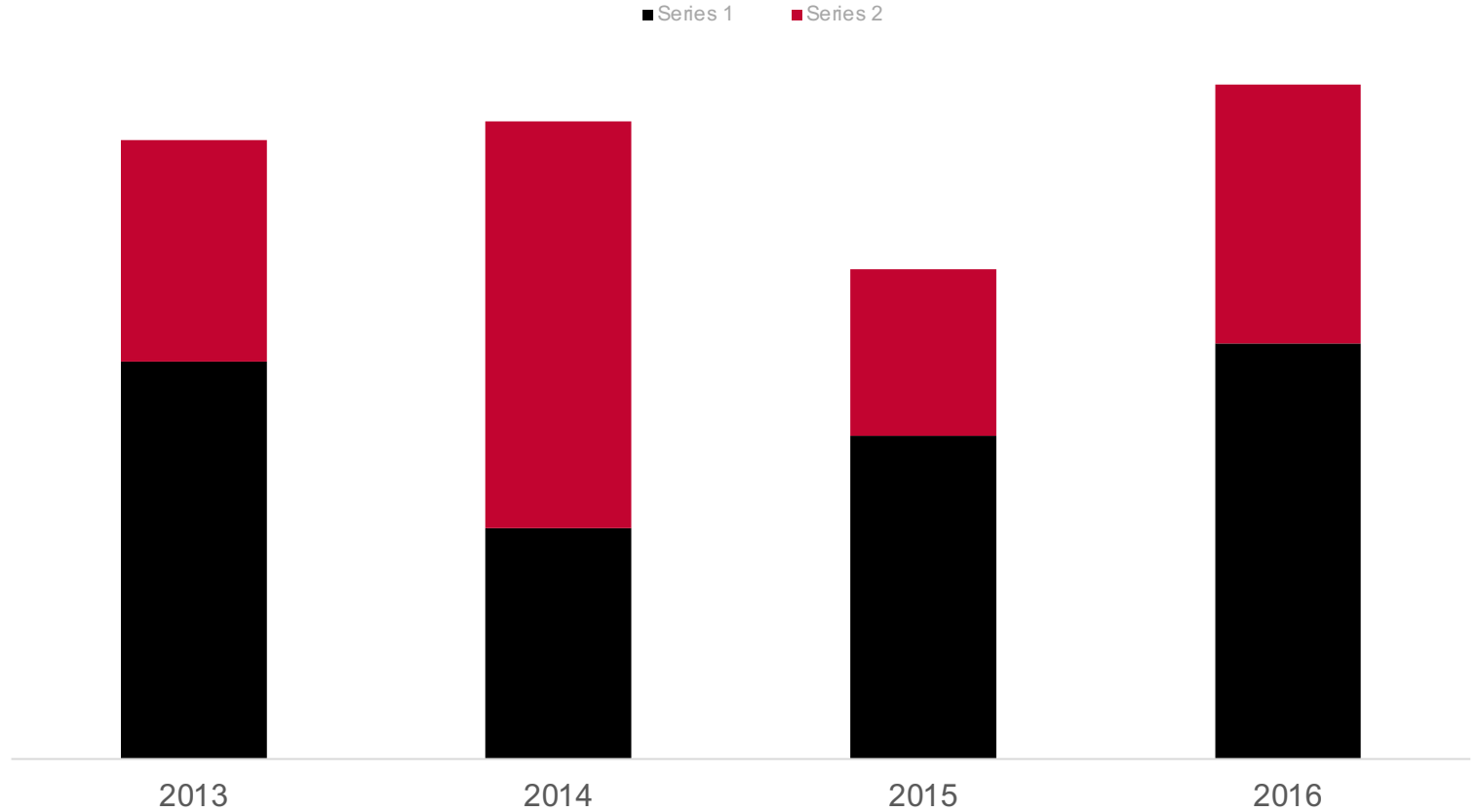

# Pie Chart Example

Description of the chart title goes here

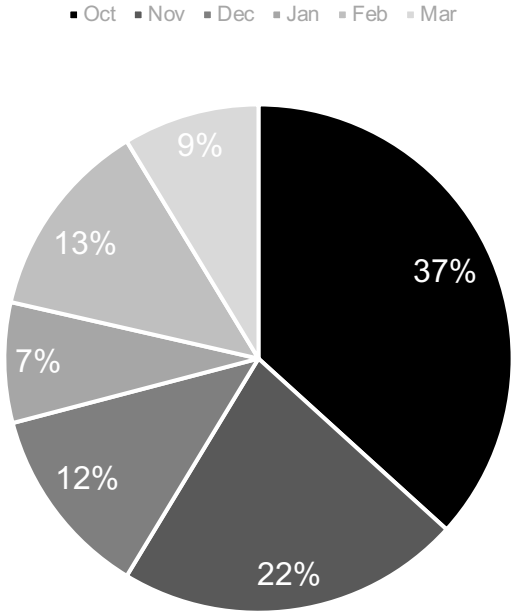

Lorem ipsum dolor sit amet, consectetur adipiscing elit. Maecenas porttitor congue.

Lorem ipsum dolor sit amet, consectetur adipiscing elit. Maecenas porttitor congue.

## 63%

Section

Lorem ipsum dolor sit amet.

## 45%

Section

Lorem ipsum dolor sit amet.

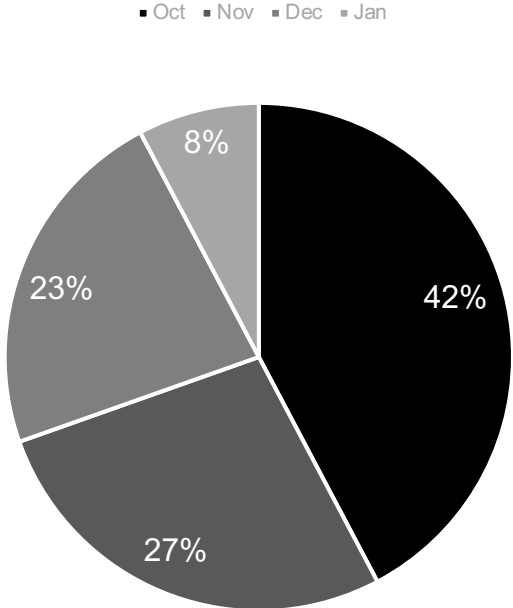

# Pie Chart Example



Description of the chart title goes here

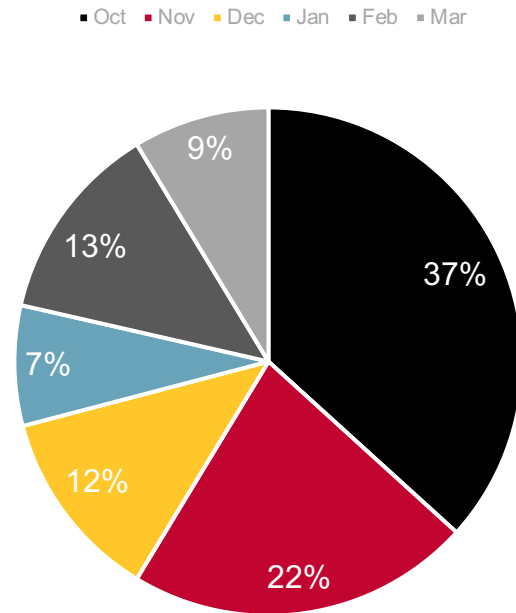

Lorem ipsum dolor sit amet, consectetur adipiscing elit. Maecenas porttitor congue.

Lorem ipsum dolor sit amet, consectetur adipiscing elit. Maecenas porttitor congue.

## 63%

**Section**

Lorem ipsum dolor sit amet.

## 45%

**Section**

Lorem ipsum dolor sit amet.

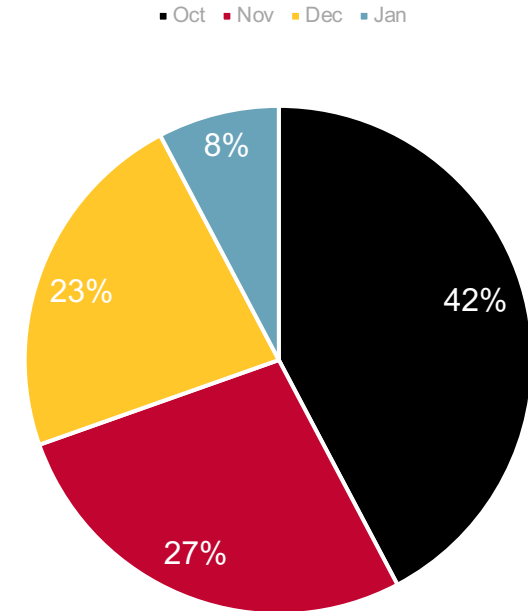
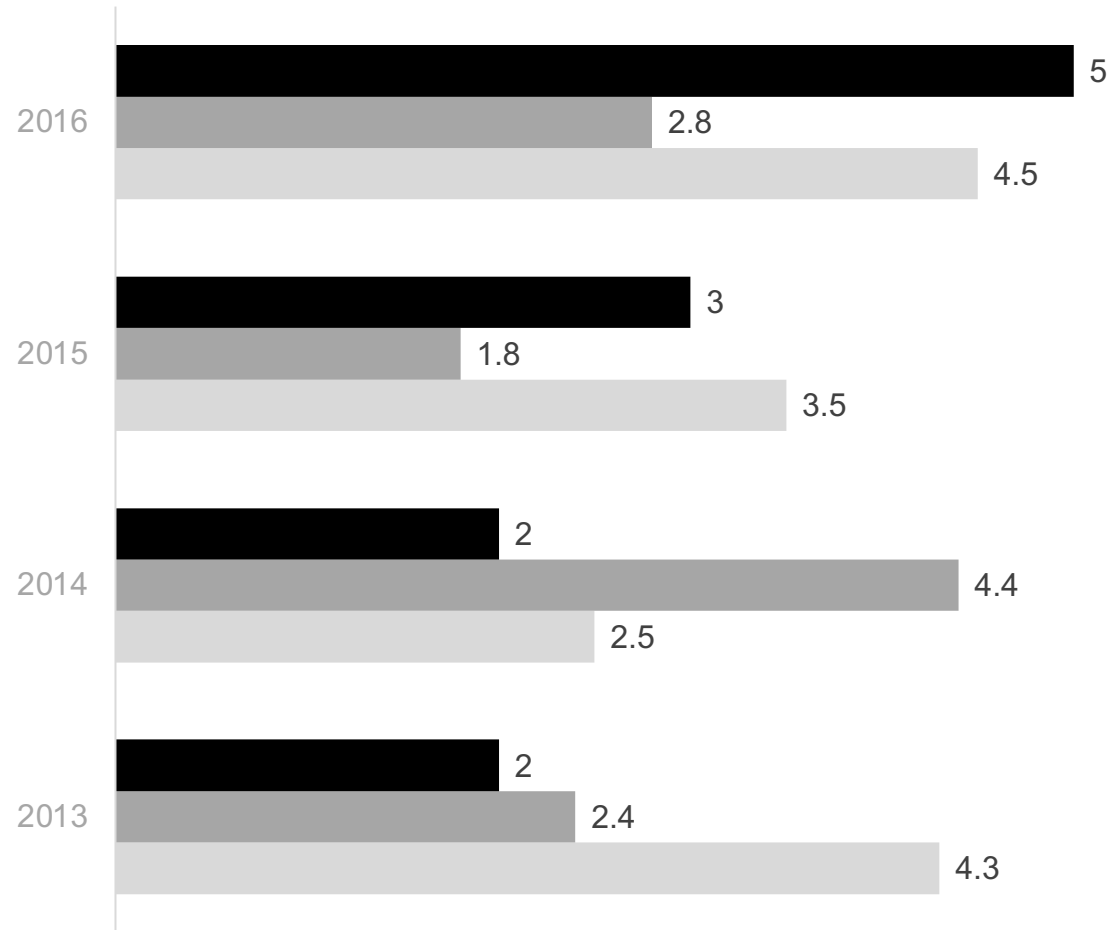

Chart Title



# Easy line chart

- Owner
- Sponsor
- Partner



Lorem ipsum dolor sit amet, consectetur adipiscing elit. Maecenas porttitor congue massa. Fusce posuere, magna sed pulvinar ultricies, purus lectus malesuada libero, sit amet commodo magna eros quis urna.



Chart Title

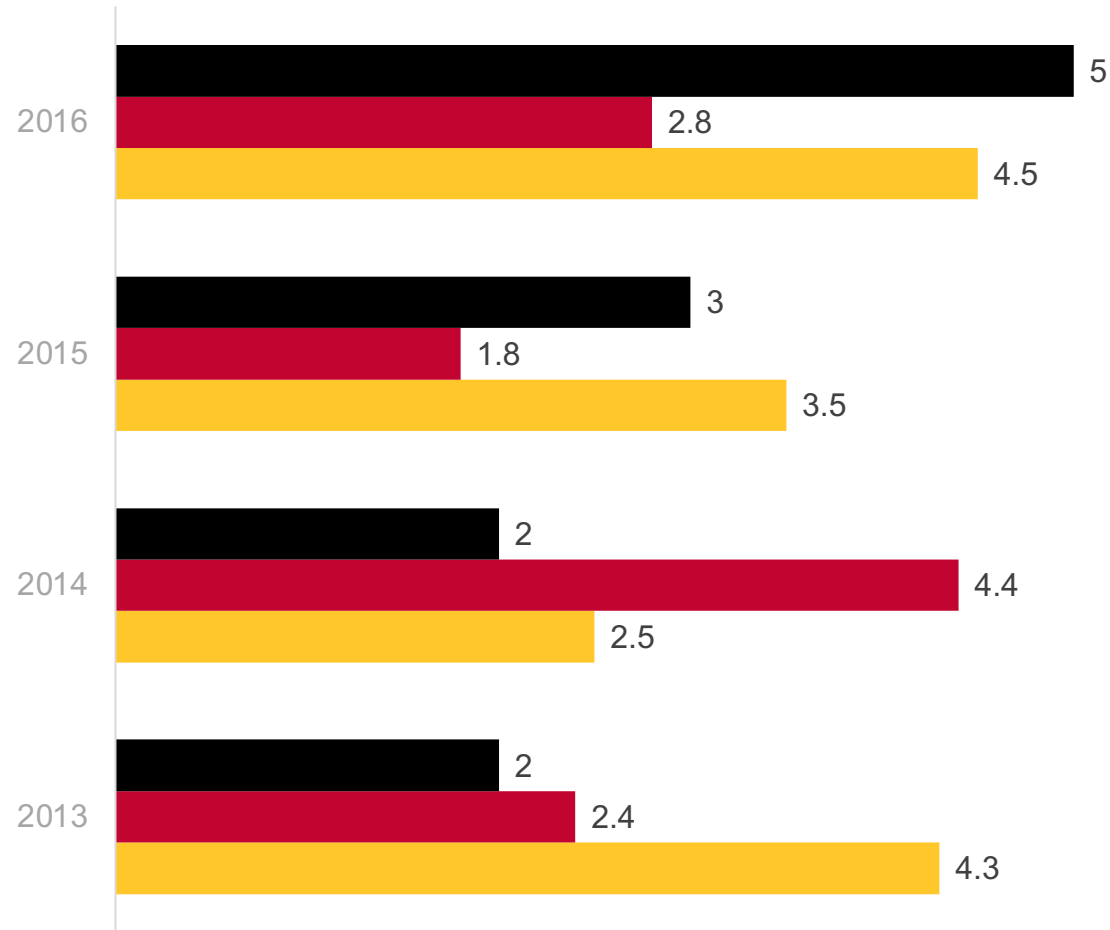

- Owner
- Sponsor
- Partner

# Easy line chart

---

Lorem ipsum dolor sit amet, consectetur adipiscing elit. Maecenas porttitor congue massa. Fusce posuere, magna sed pulvinar ultricies, purus lectus malesuada libero, sit amet commodo magna eros quis urna.

Activity charts

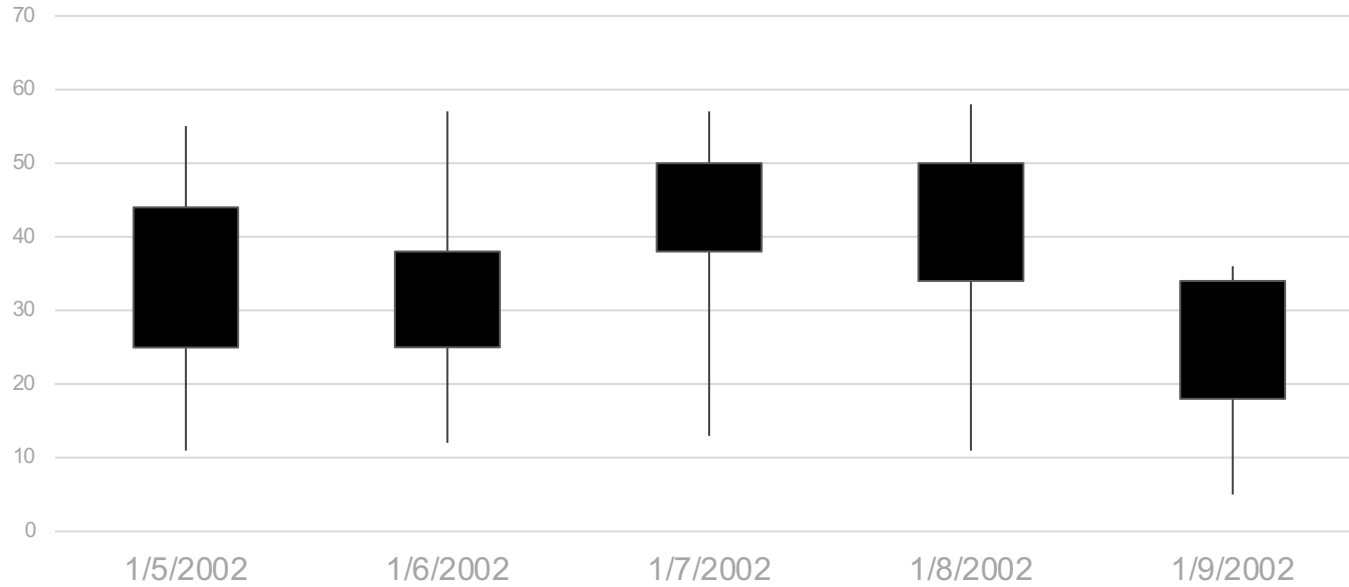

# Easy line chart



Lorem ipsum dolor sit amet, consectetur adipiscing elit. Maecenas porttitor congue massa. Fusce posuere, magna sed pulvinar ultricies, purus lectus malesuada libero, sit amet commodo magna eros quis urna.

# 83%

RECOMENDATION

Lorem ipsum dolor sit amet.

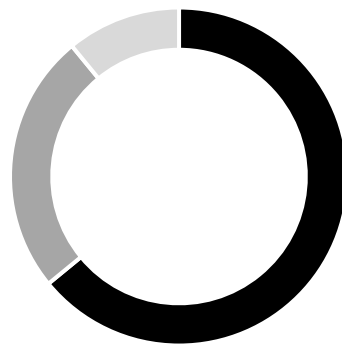

■ Europe ■ USA ■ Canada

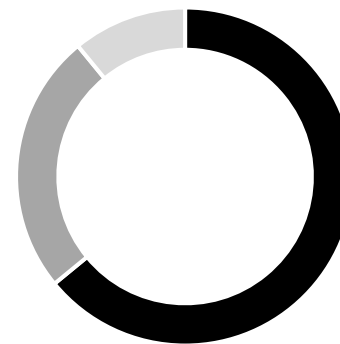

■ Europe ■ USA ■ Canada

Activity charts

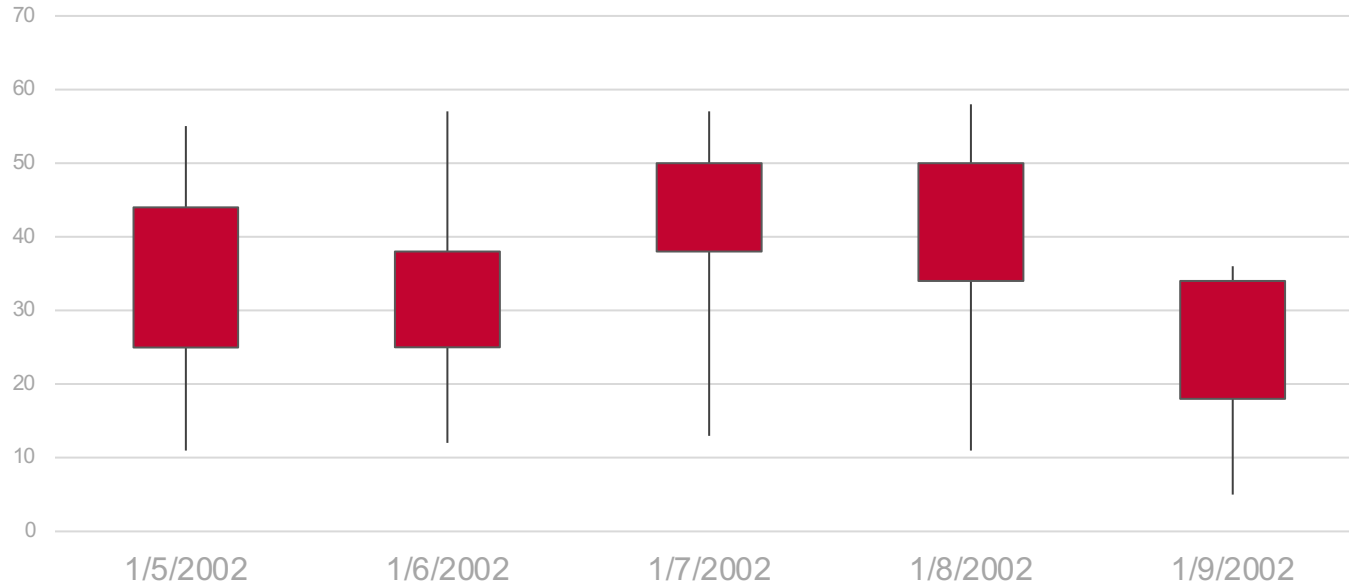

# Easy line chart



Lorem ipsum dolor sit amet, consectetur adipiscing elit. Maecenas porttitor congue massa. Fusce posuere, magna sed pulvinar ultricies, purus lectus malesuada libero, sit amet commodo magna eros quis urna.

# 83%

RECOMENDATION

Lorem ipsum dolor sit amet.



■ Europe ■ USA ■ Canada



■ Europe ■ USA ■ Canada

# Bar column

—

Lorem ipsum dolor sit amet, consectetur adipiscing elit. Maecenas porttitor congue massa. Fusce posuere, magna sed pulvinar ultricies, purus lectus malesuada libero, sit amet commodo magna eros quis urna.

Chart Title

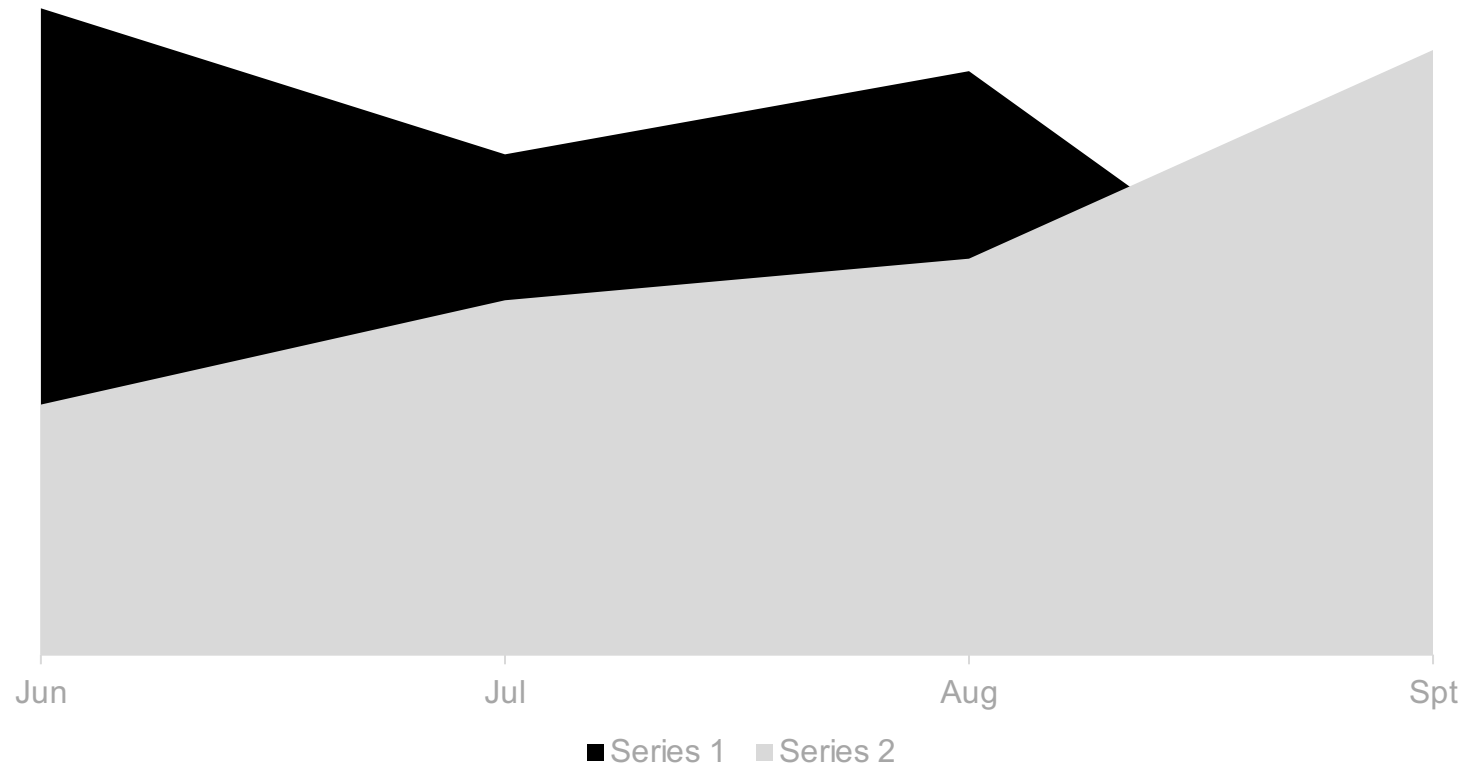

# Bar column



Lorem ipsum dolor sit amet, consectetur adipiscing elit. Maecenas porttitor congue massa. Fusce posuere, magna sed pulvinar ultricies, purus lectus malesuada libero, sit amet commodo magna eros quis urna.

Chart Title

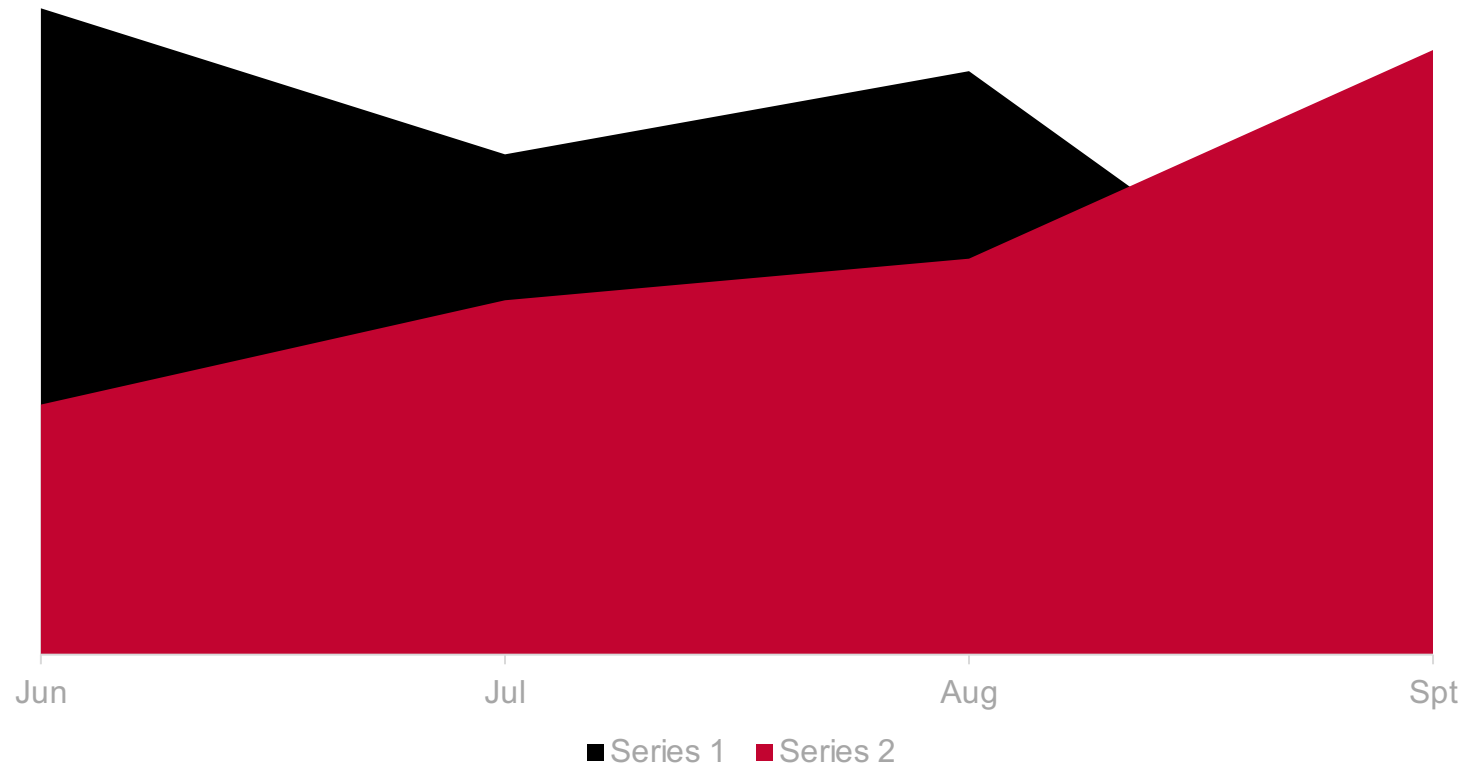

The End.