

Nuclear Physics with Storage Rings

Yury A. Litvinov

HELMHOLTZ
RESEARCH FOR GRAND CHALLENGES

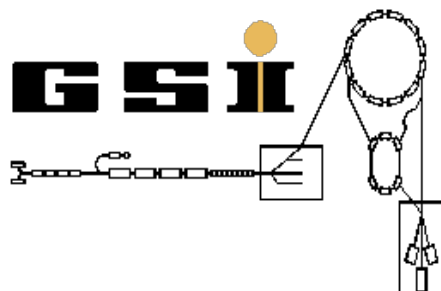

IUPAP WG9/C12 Meeting and Nuclear Science Symposium 2026
Enrico Fermi Center, Rome, Italy
15-16 April 2026



www.gsi.de/astrum

HELMHOLTZ GSI



The NuPECC Long Range Plan 2024 for European Nuclear Physics

- Europe's world leadership in the use of heavy ion storage rings - as key precision instruments for the study of nuclear masses and radii, nuclear resonances, isomers, reactions and fission - should be maintained by the construction of **future rings at FAIR and HIE-ISOLDE**.

- Heavy-ion storage rings are key precision instruments for **future studies on nuclear masses and radii, reactions, nuclear resonances, isomers and fission**. The world leadership of Europe in the use of heavy ion storage rings should be maintained by supporting experiments in the existing low energy storage rings of *GSI/FAIR (ESR and CRYRING)* and, in a larger time frame, the construction of future storage rings at *GSI/FAIR and HIE-ISOLDE* (see more in



Heavy-Ion Storage Rings - Versatile Instruments

Dedicated beam preparation and manipulation techniques



Storage - efficient
use of rare species

A huge trap – tens of meters in circumference,
Large aperture size – 10-25 cm

**Nuclear reaction inevitably leads to large
momentum spread of the secondary beam**

Beam cooling - high quality beams
Isochronous mode – high mass resolution

Small production rates of secondary beams

Accumulation techniques
Single-particle sensitivity detection

Short-lived species

Instantaneous detection
Non-destructive detection

CRYRING at GSI



ESR at GSI



R3 at RIKEN



CSRe at IMP

Electron Cooling of Secondary Beams



Exchange of momenta

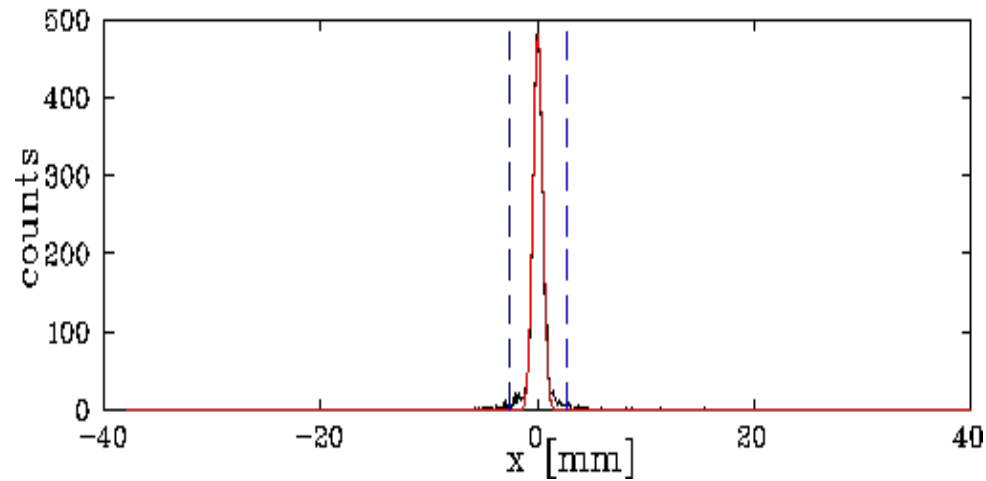
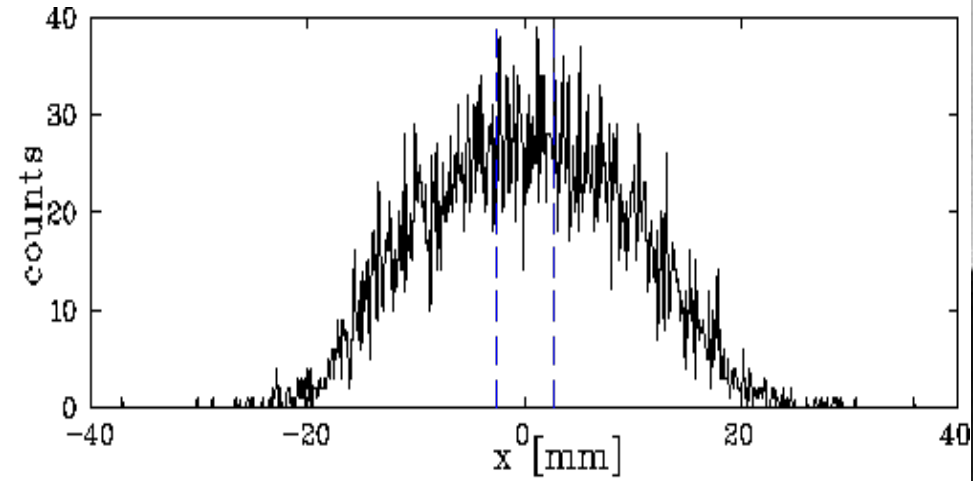

$$\frac{\Delta v}{v} \approx 1 \cdot 10^{-7}$$

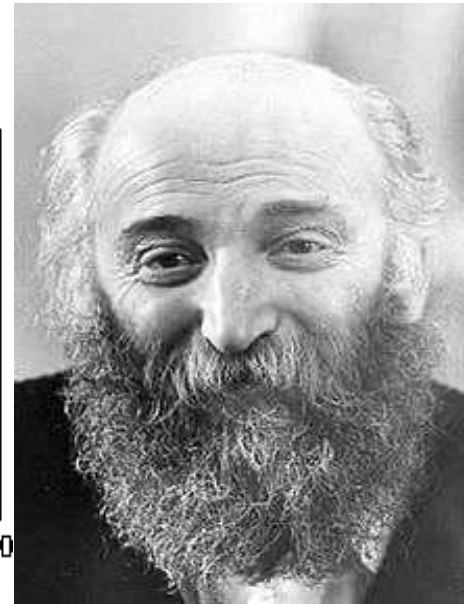

Gersh I. Budker
1918 - 1977



Markus Steck 2025+

Proton-Capture Reactions in the ESR

Deceleration

- refill ring periodically
- injection of ions @ >100 MeV/u
 - ✓ fully stripped ions
 - deceleration & cooling of the beam
 - ✓ $E = 3 - 10$ MeV/u
 - activate internal **hydrogen target**
 - ✓ proton & electron capture reactions
 - ✓ separated by dipole
 - ✓ particle detectors on...
 - ... inner tracks for (p, γ) products
 - ... outer tracks for e^- capture products
 - beam life time (residual gas + target interaction)
 - intensity goes down

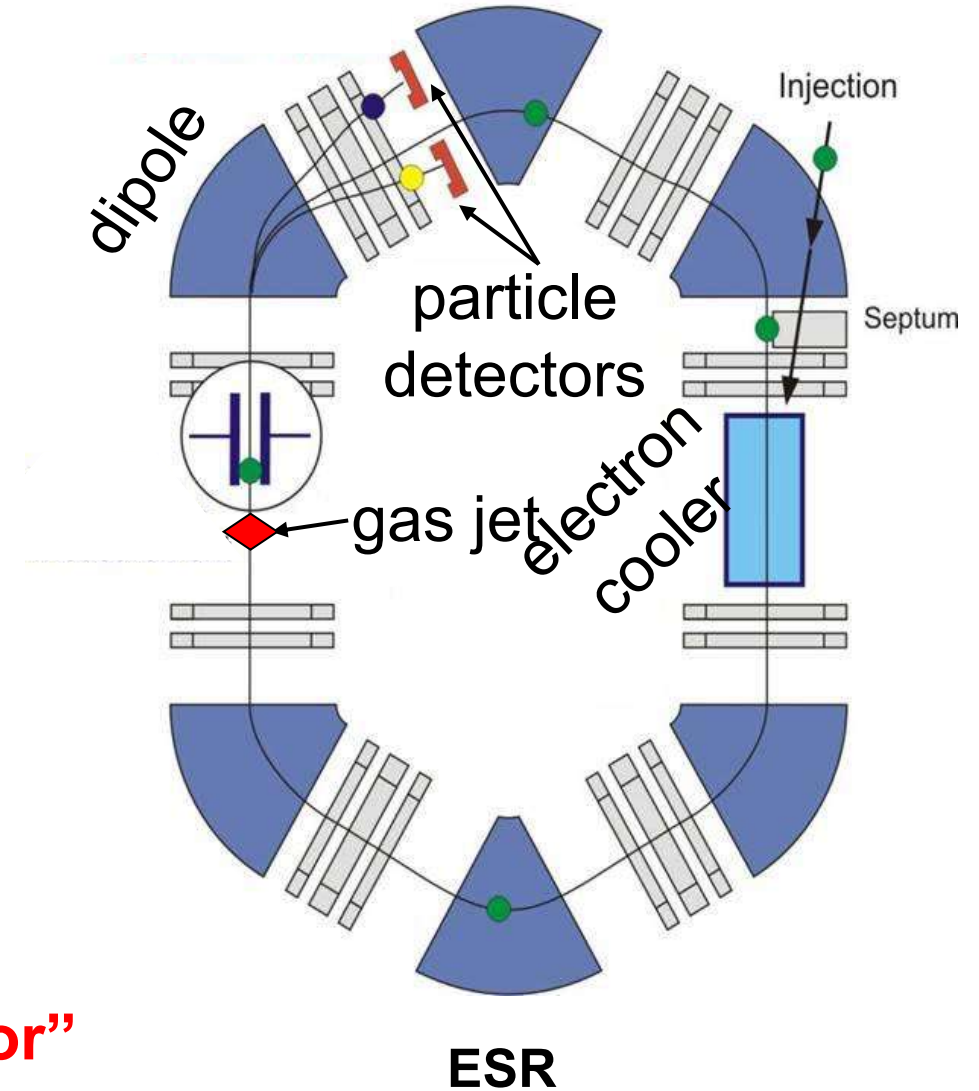

Jan Glorius: "A recycling recoil separator"

Proton-Induced Reactions in the Experimental Storage Ring

(p,g) and (p,n) reaction products

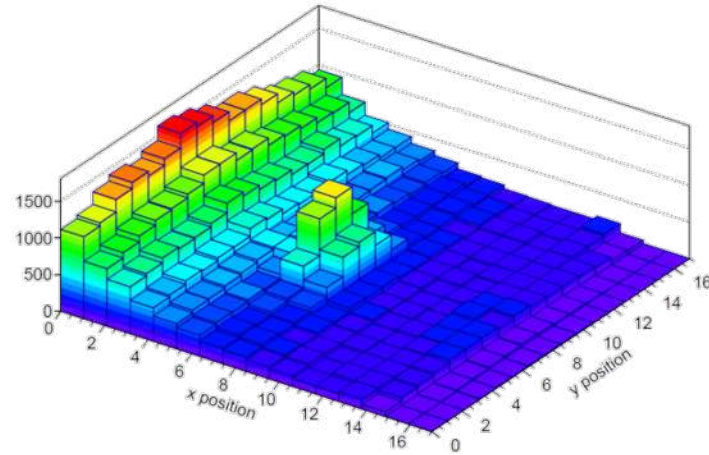
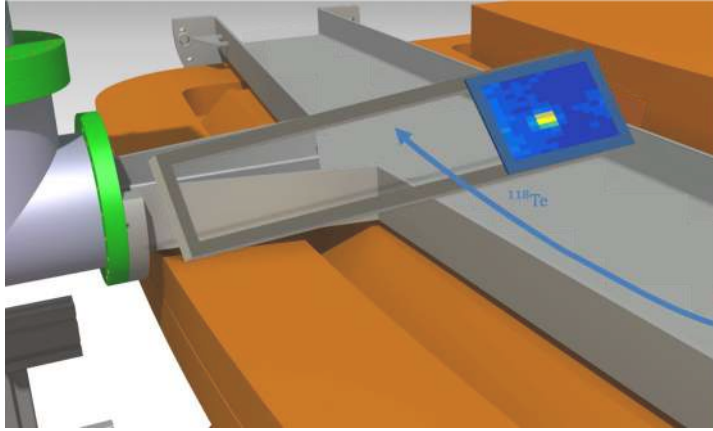

radiative e^- capture rate [REC]

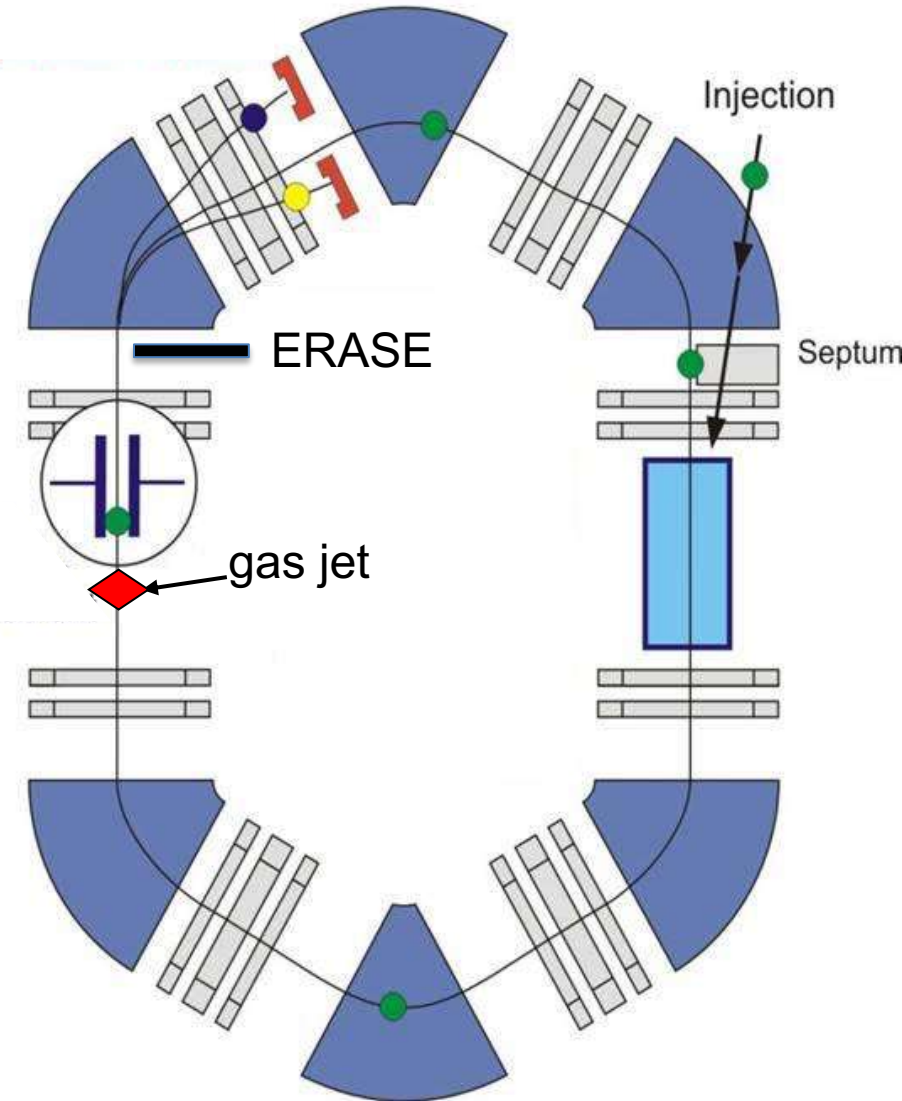
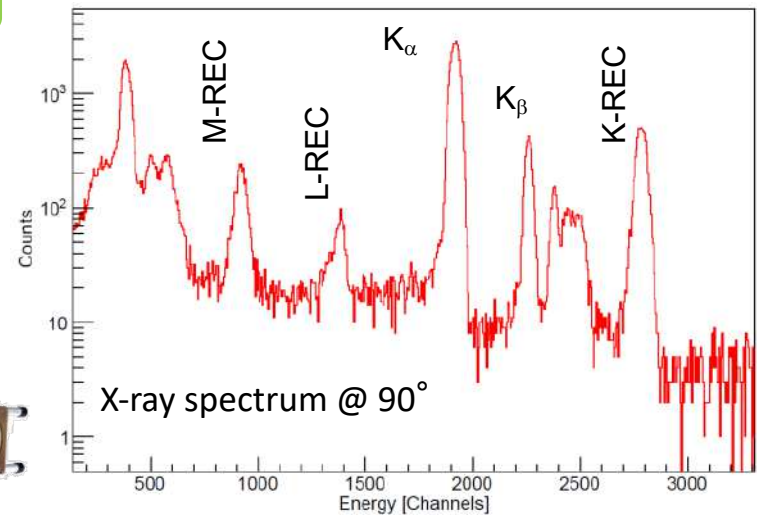
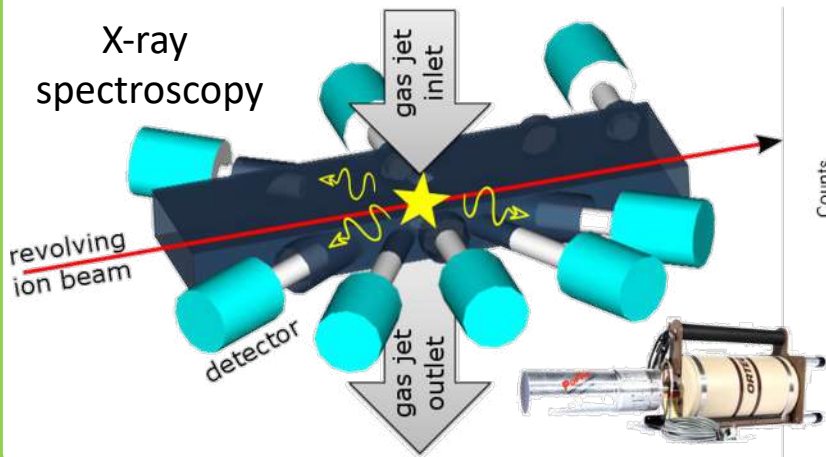

Towards background free measurement

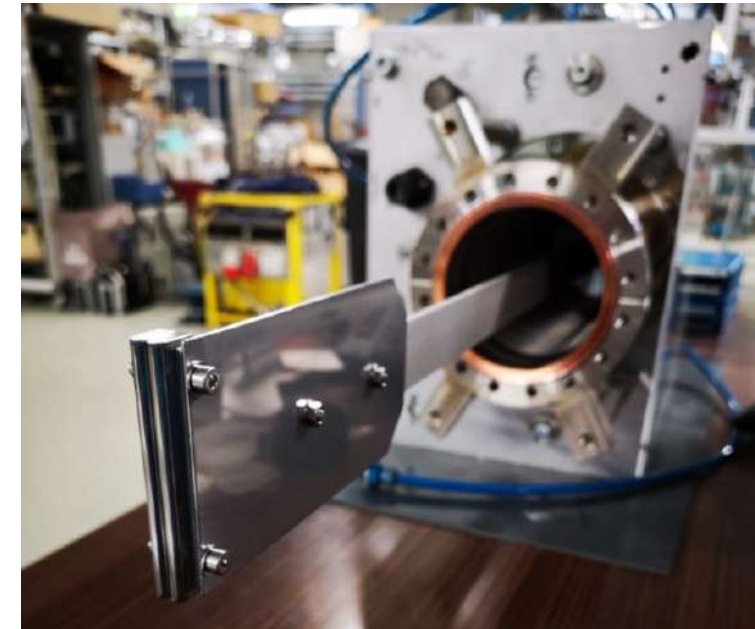
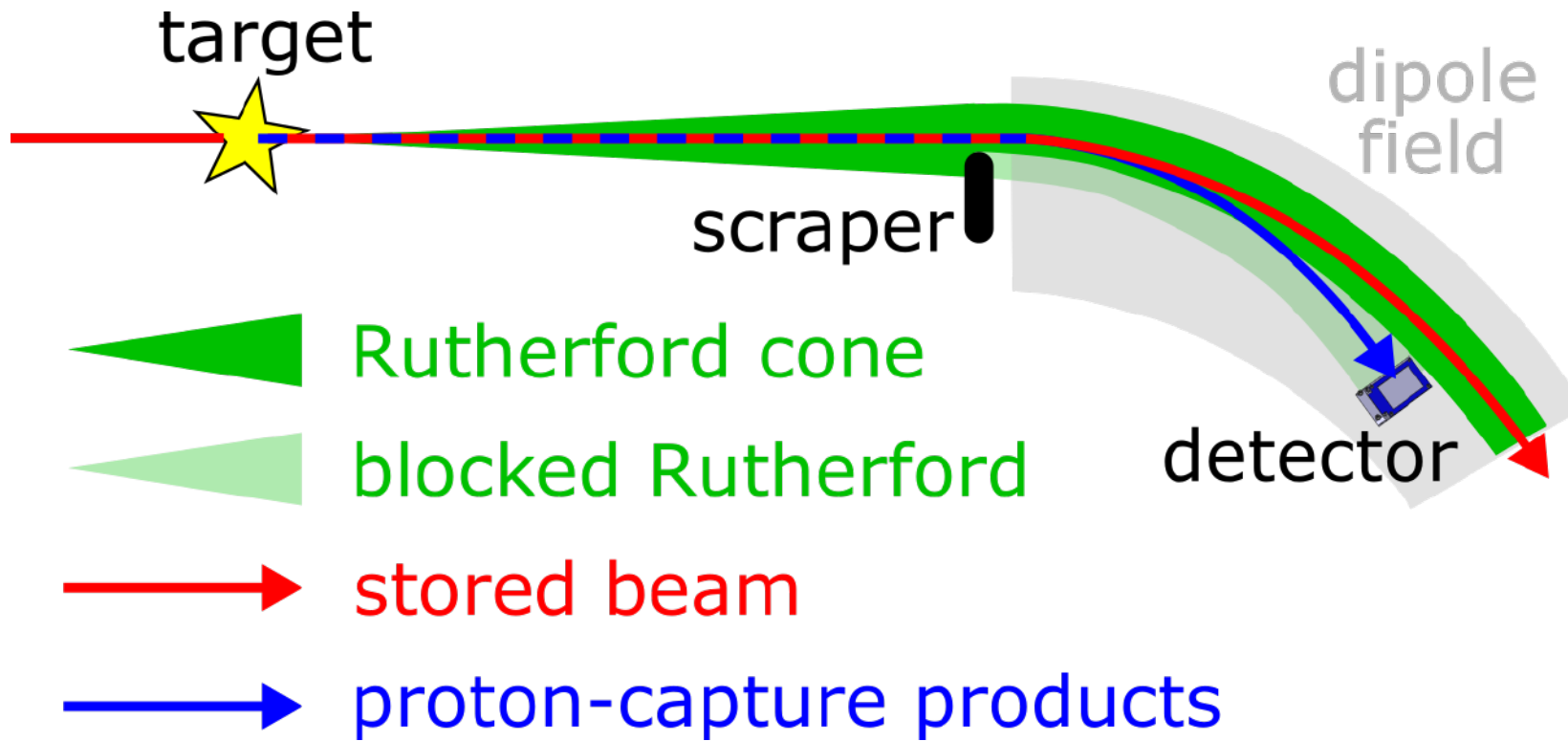

Proton-Induced Reactions in the Experimental Storage Ring

ERASE vs no-ERASE: $^{124}\text{Xe}(p,x)$

$^{124}\text{Xe}(p,\gamma)$

- 10^7 bare ions stored
- cooled and decelerated to 7 MeV/u



nearly background-free measurement
maximized experimental sensitivity

**(p,n) reaction channel measured
simultaneously**

No ERASE

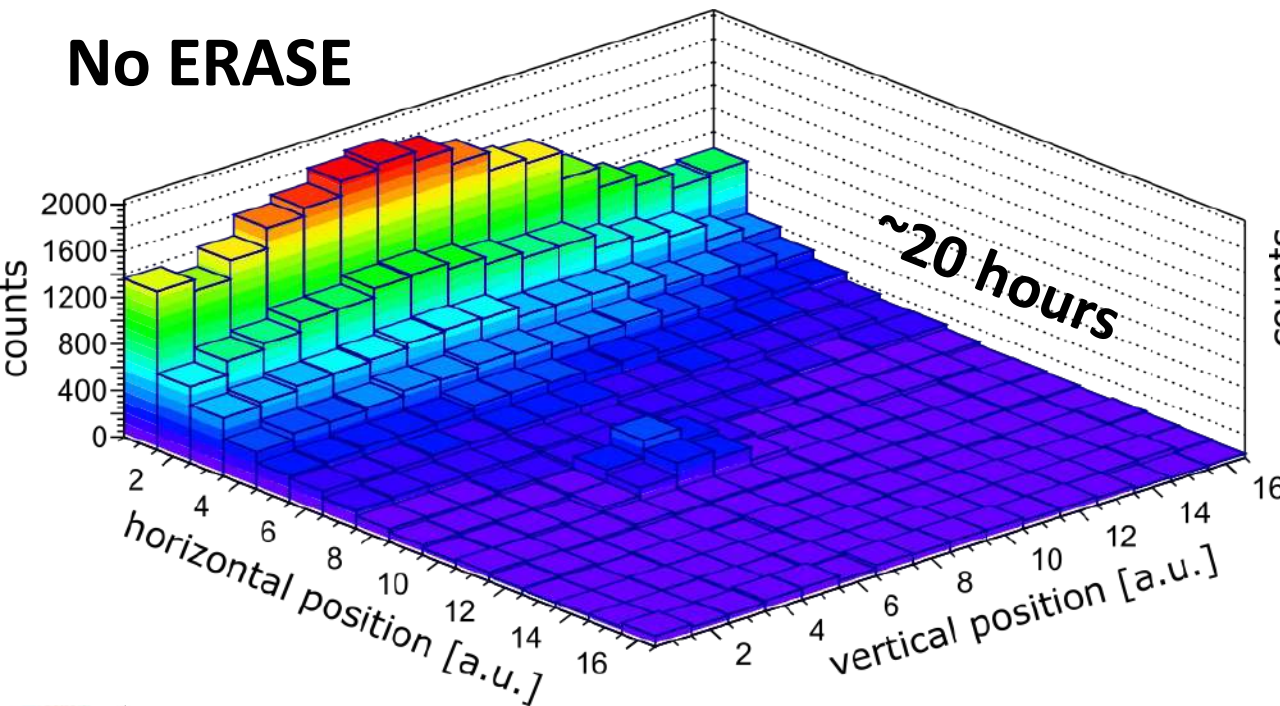

ERASE

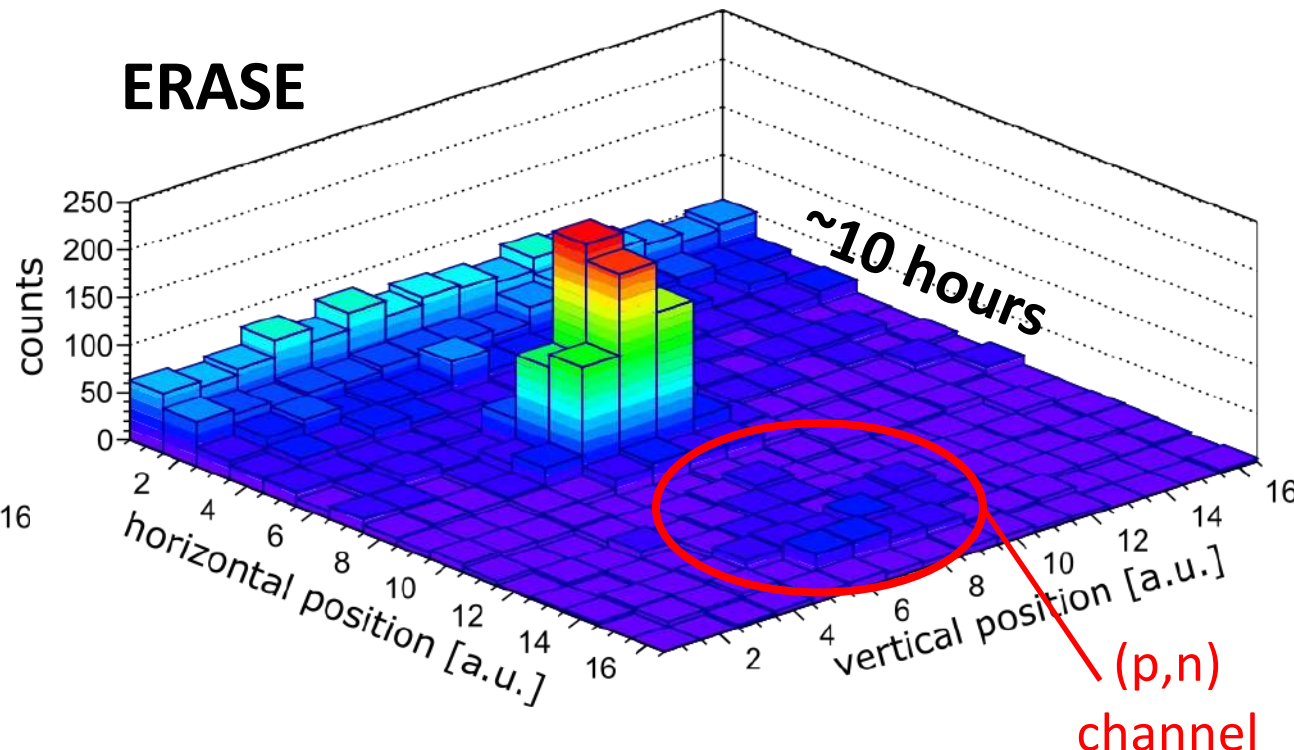

Proton-Induced Reactions in the Experimental Storage Ring

First study on radioactive ion beam

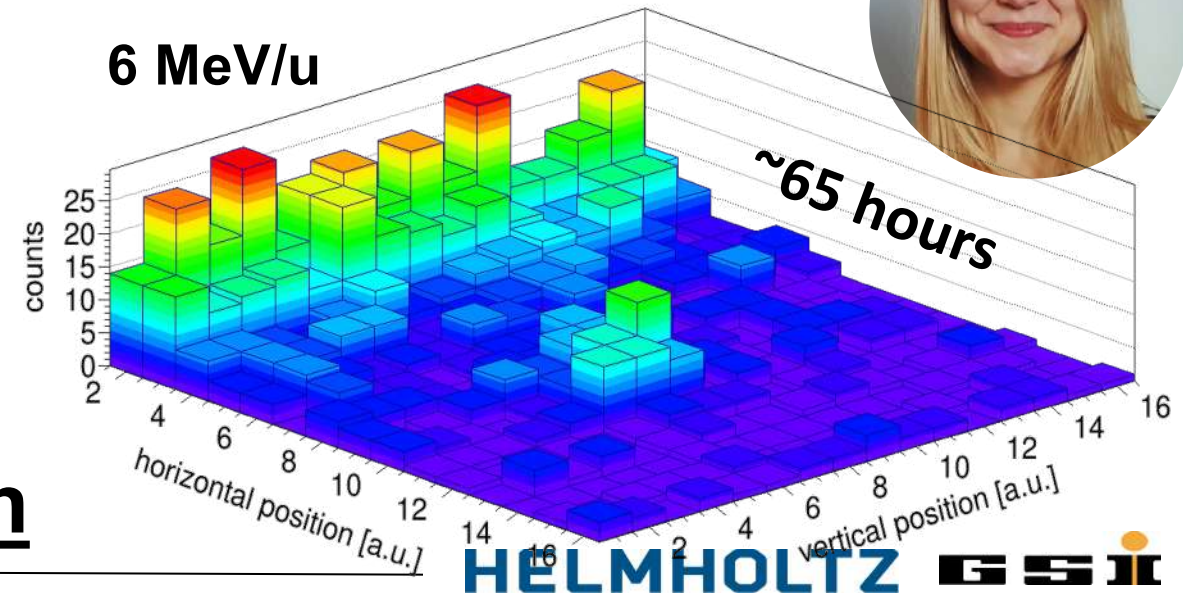
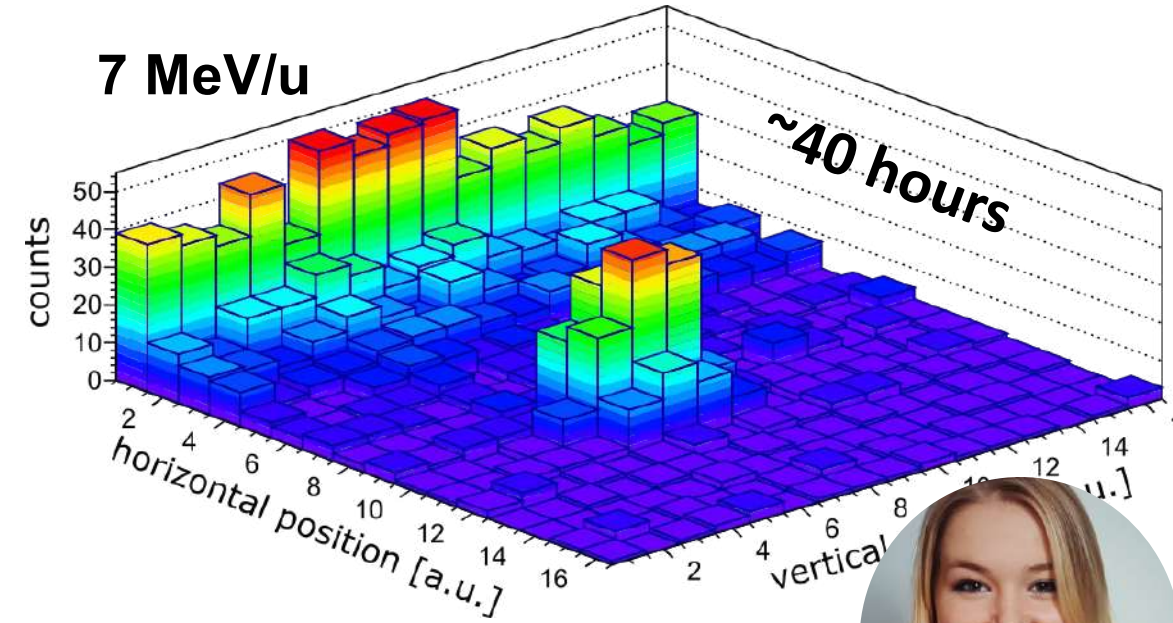
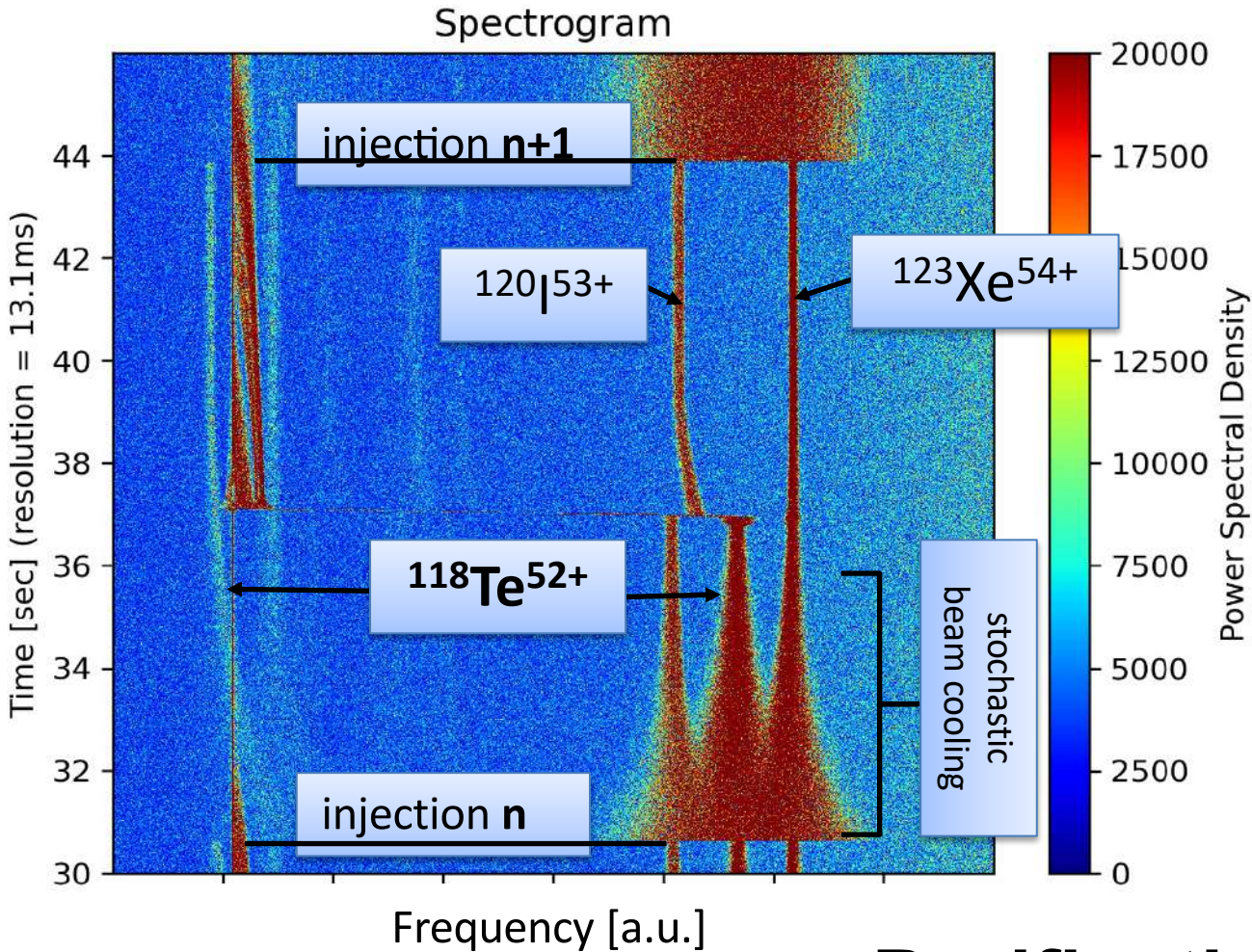

Purification

Proton capture on radioactive ^{118}Te

Accumulation

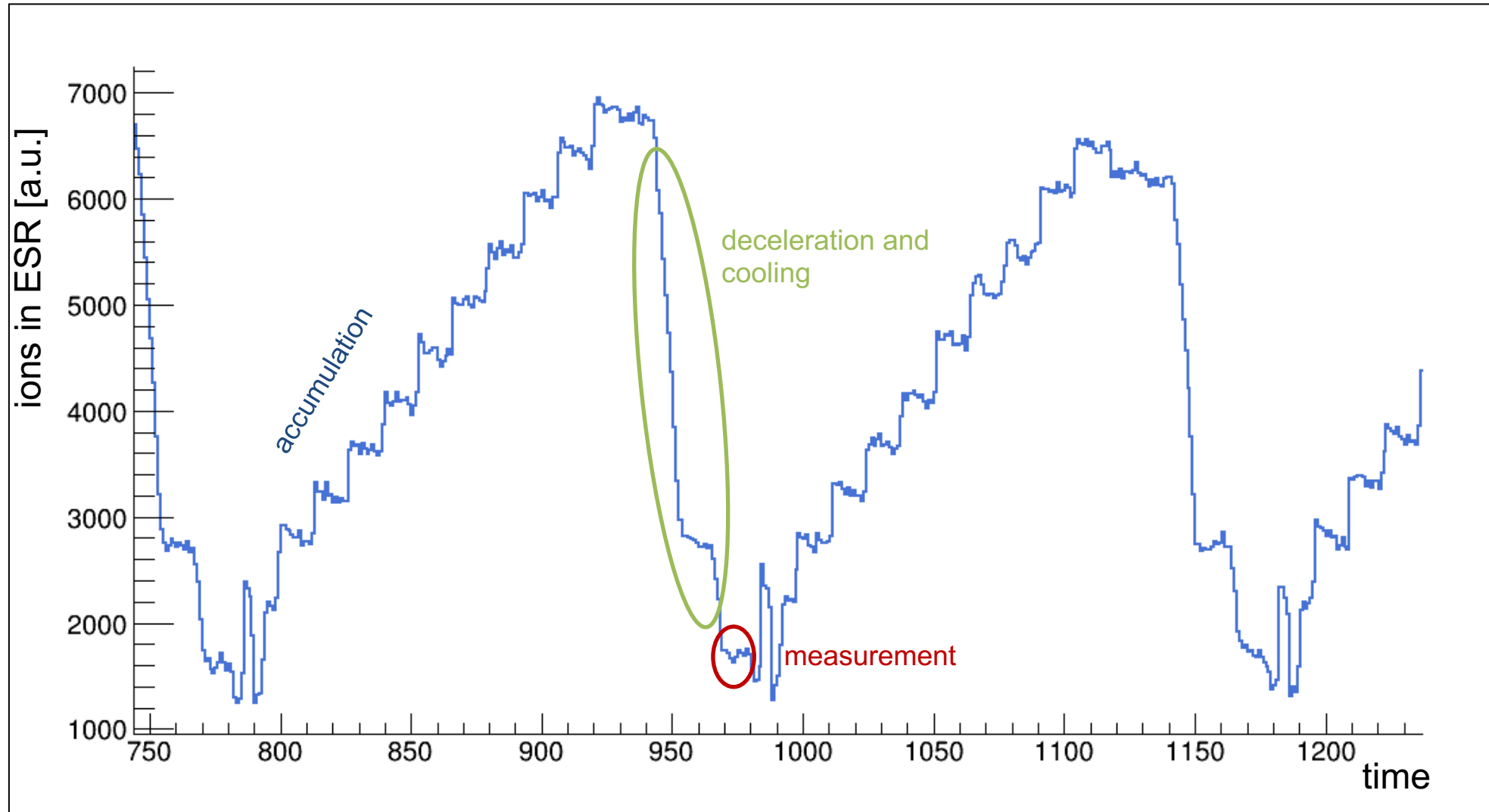

The CRYRING@ESR facility

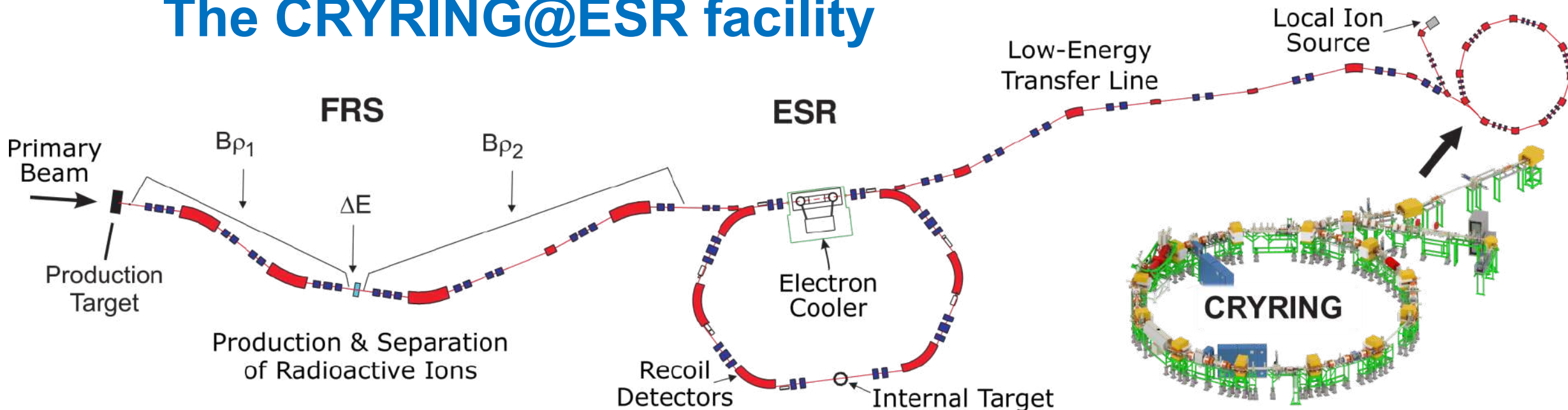

CRYRING (transported from Stockholm University)

Start of operation (local source) – 2019
Start of operation (beams from ESR) – 2020
Circumference = 54.15 m
XH Vacuum = 10^{-11} – 10^{-12} mbar
Electron cooling
Energy range = ~ 0.1 – 15 MeV/u
Slow and fast extraction



M. Lestinsky, GSI, Darmstadt

The CRYRING@ESR facility

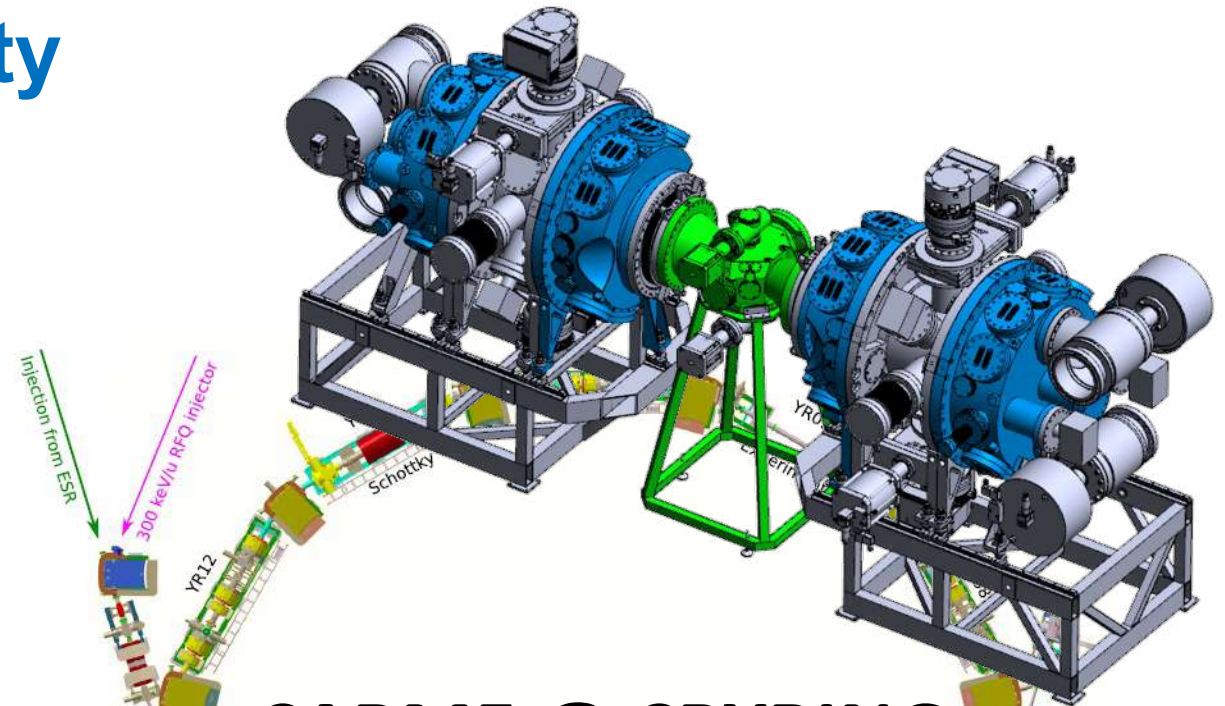
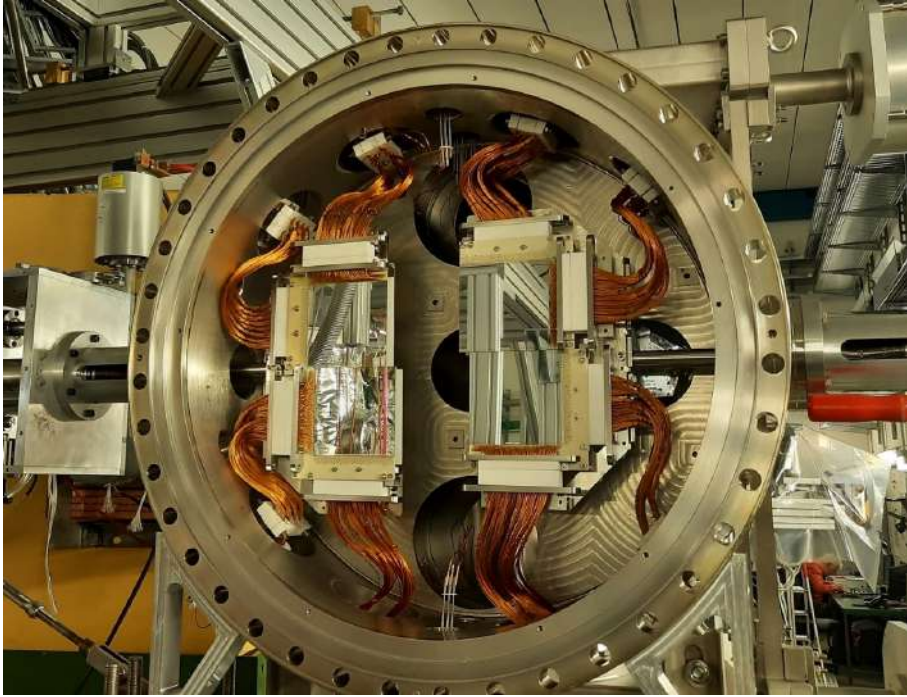

CARME @ CRYRING

(CRYRING Array for Reaction MEasurements)

Carlo Bruno
Jordan Marsh
Phil Woods
Tom Davinson

${}^7\text{Li}+p$

$d+d$



European Research Council
Established by the European Commission



Science & Technology
Facilities Council



Commissioning and first results with CARME

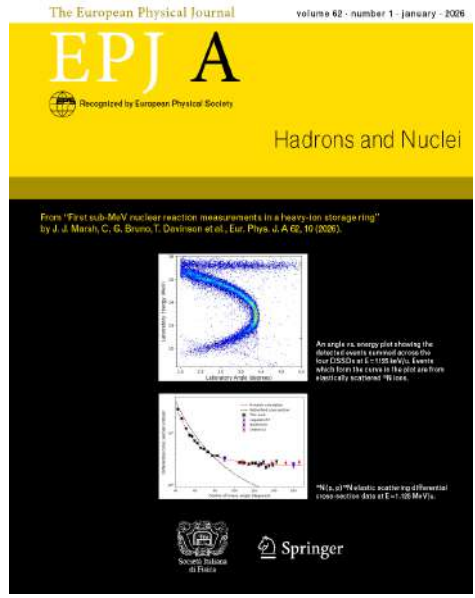
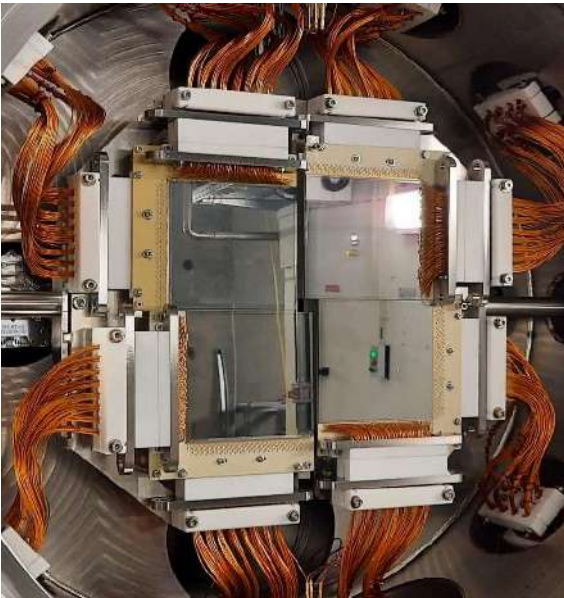
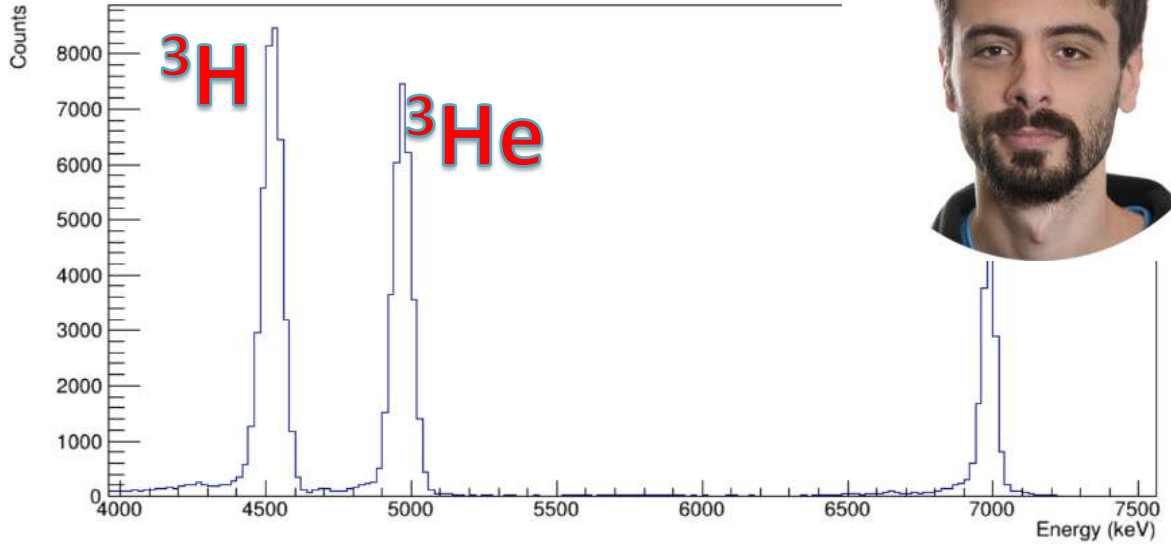
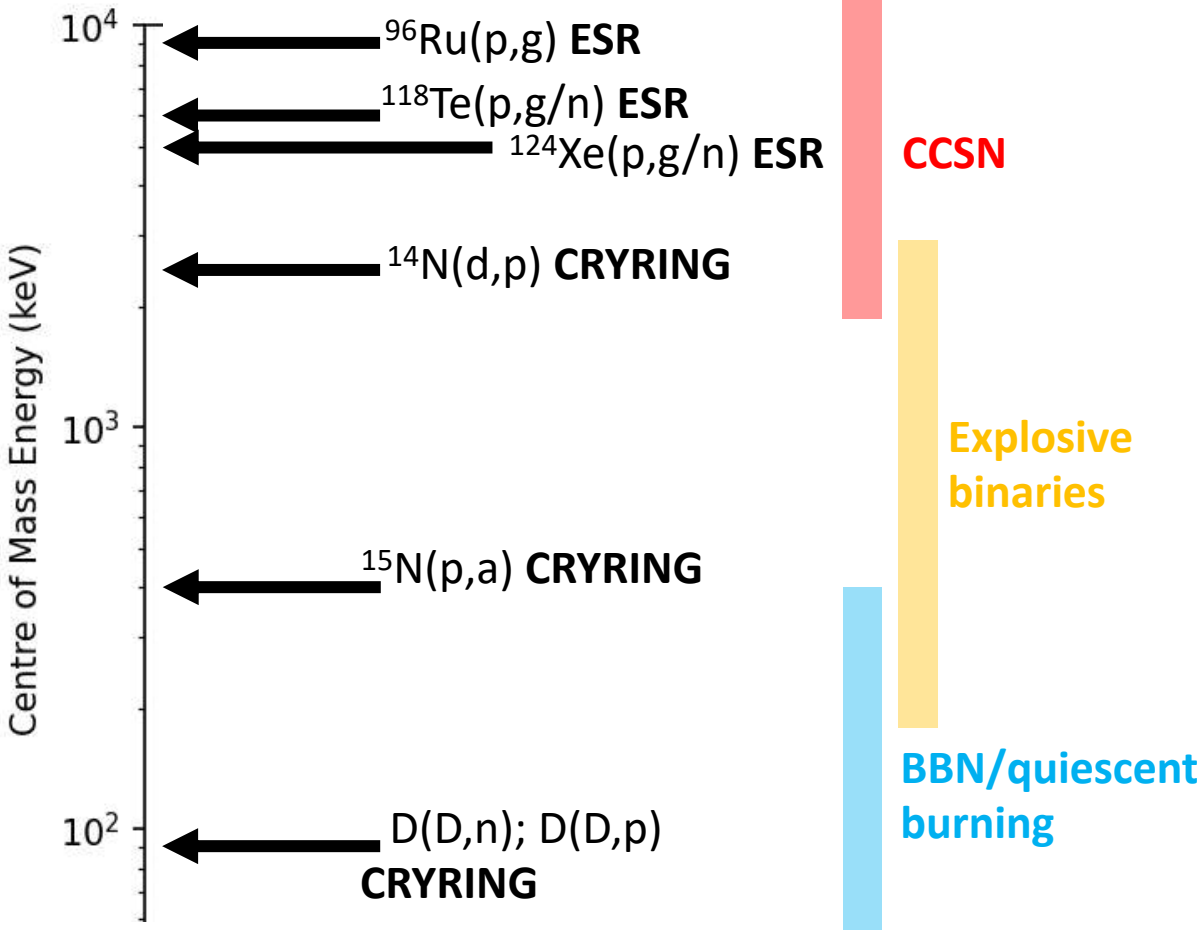

Development of Schottky Detectors: Sensitivity to single ions

1992

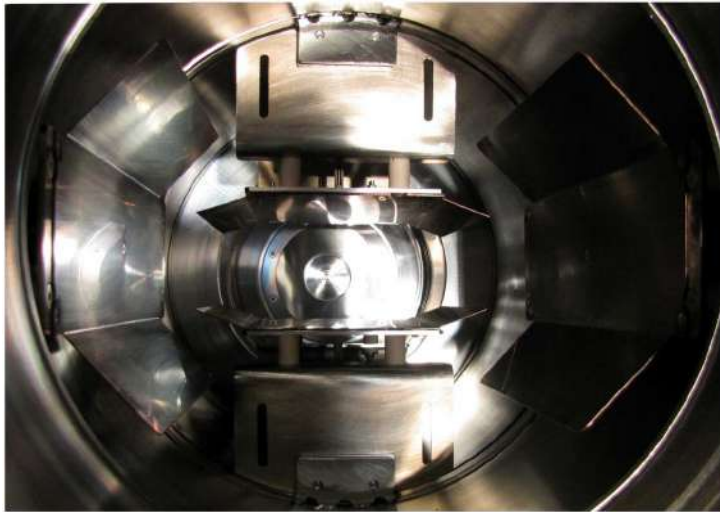

2011 F. Nolden et al., NIM A (2011)

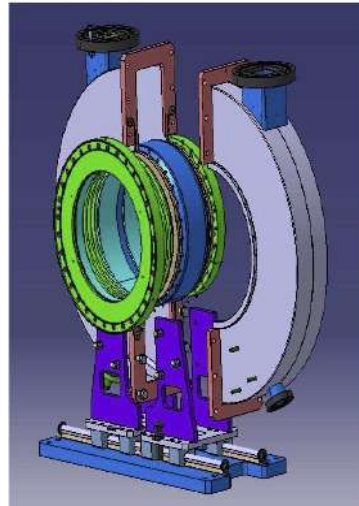

2020 M. S. Sanjari et al., RSI 91 (2020) 083303

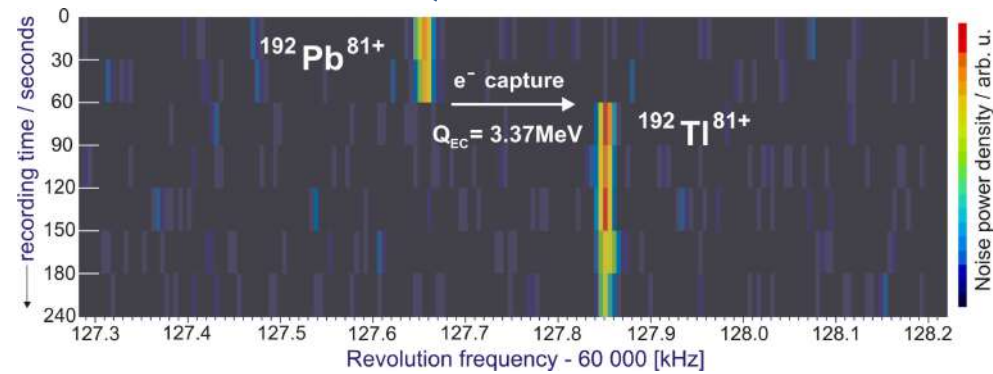
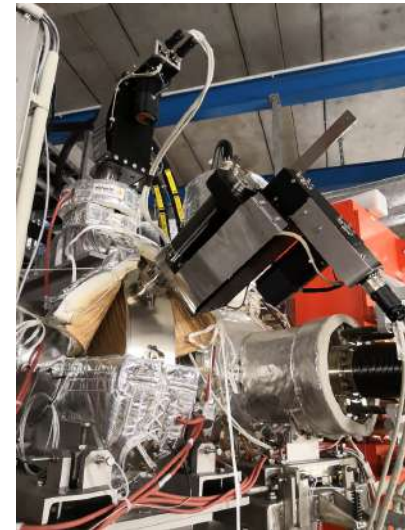

~30 sec / spectrum
- Masses and lifetimes ($T_{1/2} > 5$ s)

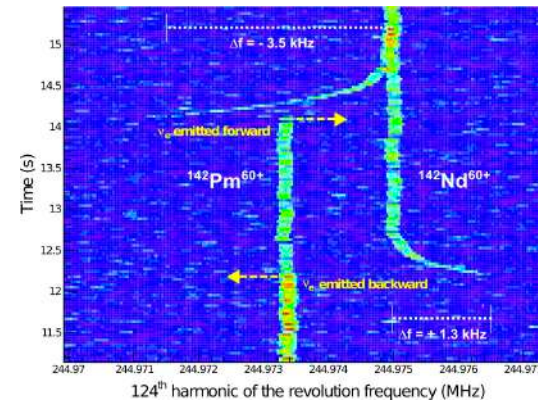

~30 ms/spectrum
- Longitudinal changes of momenta
- E-cooling process

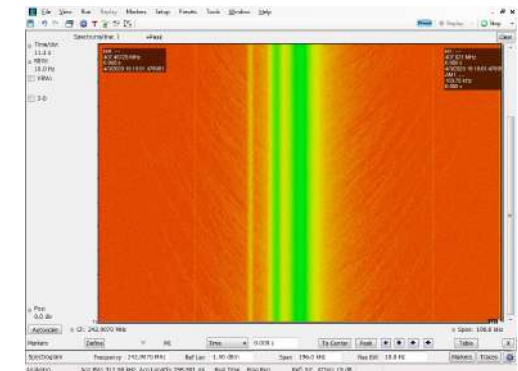

Intra-beam scattering

Combined Isochronous+Schottky Mass Spectrometry

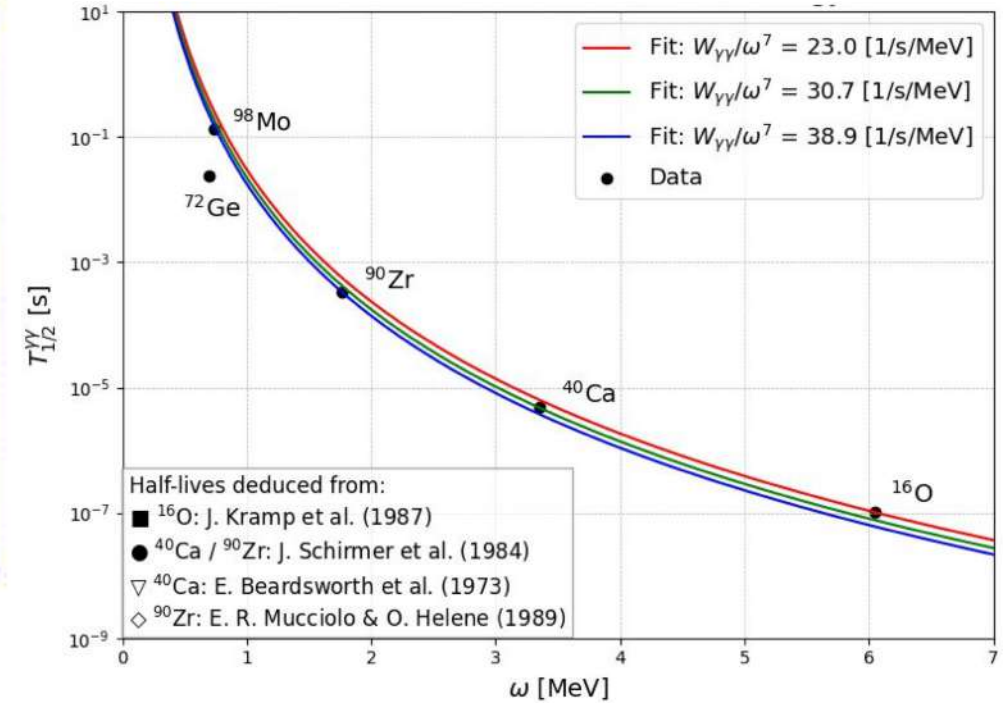
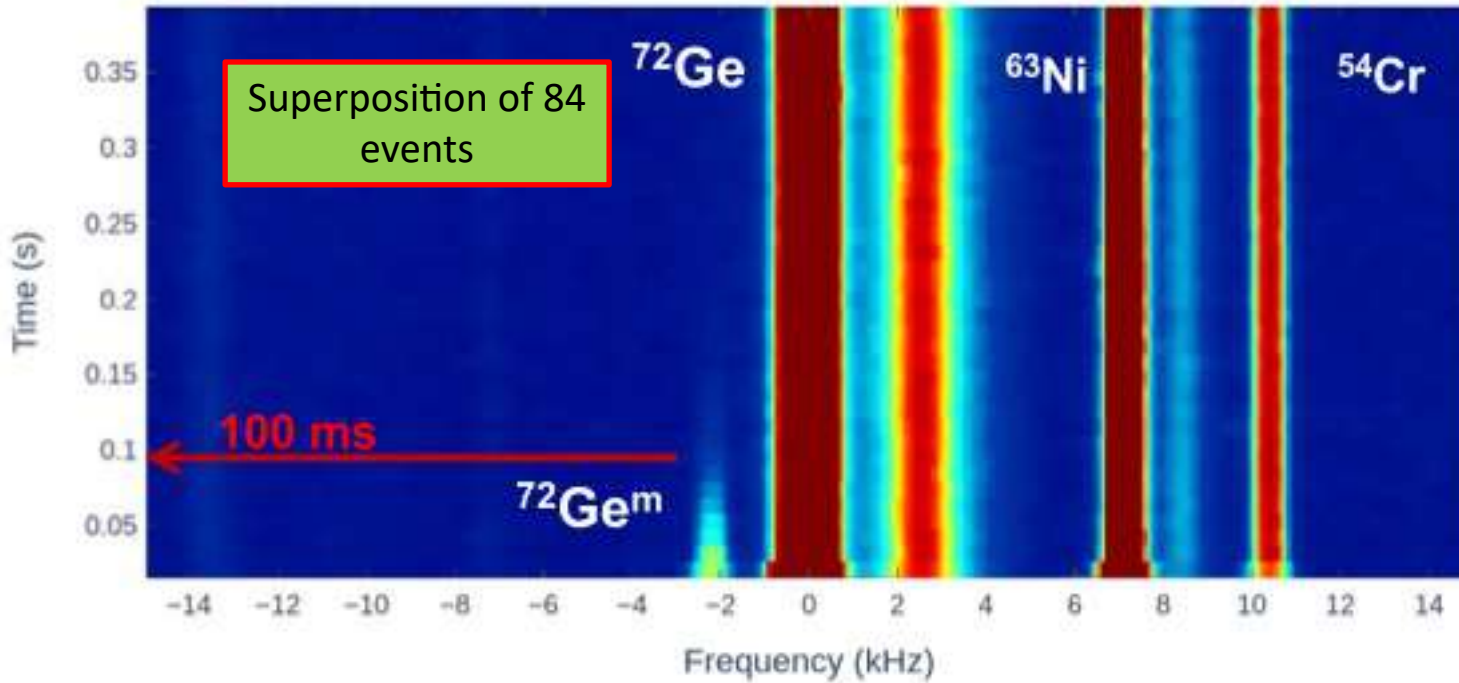

$^{72}\text{Ge}^m$: $0^+ \rightarrow 0^+$ (single γ emission forbidden)

New tool to search for 0^+ isomers in exotic nuclei
 $0^+ \rightarrow 0^+$ decays as laboratory for BSM physics

Decays of the first 0^+ states were measured also in ^{98}Zr , ^{98}Mo



Mass & half-life measurements in the neutron-rich $N \approx 116$ Hf region

8 hours data taking in April 2025

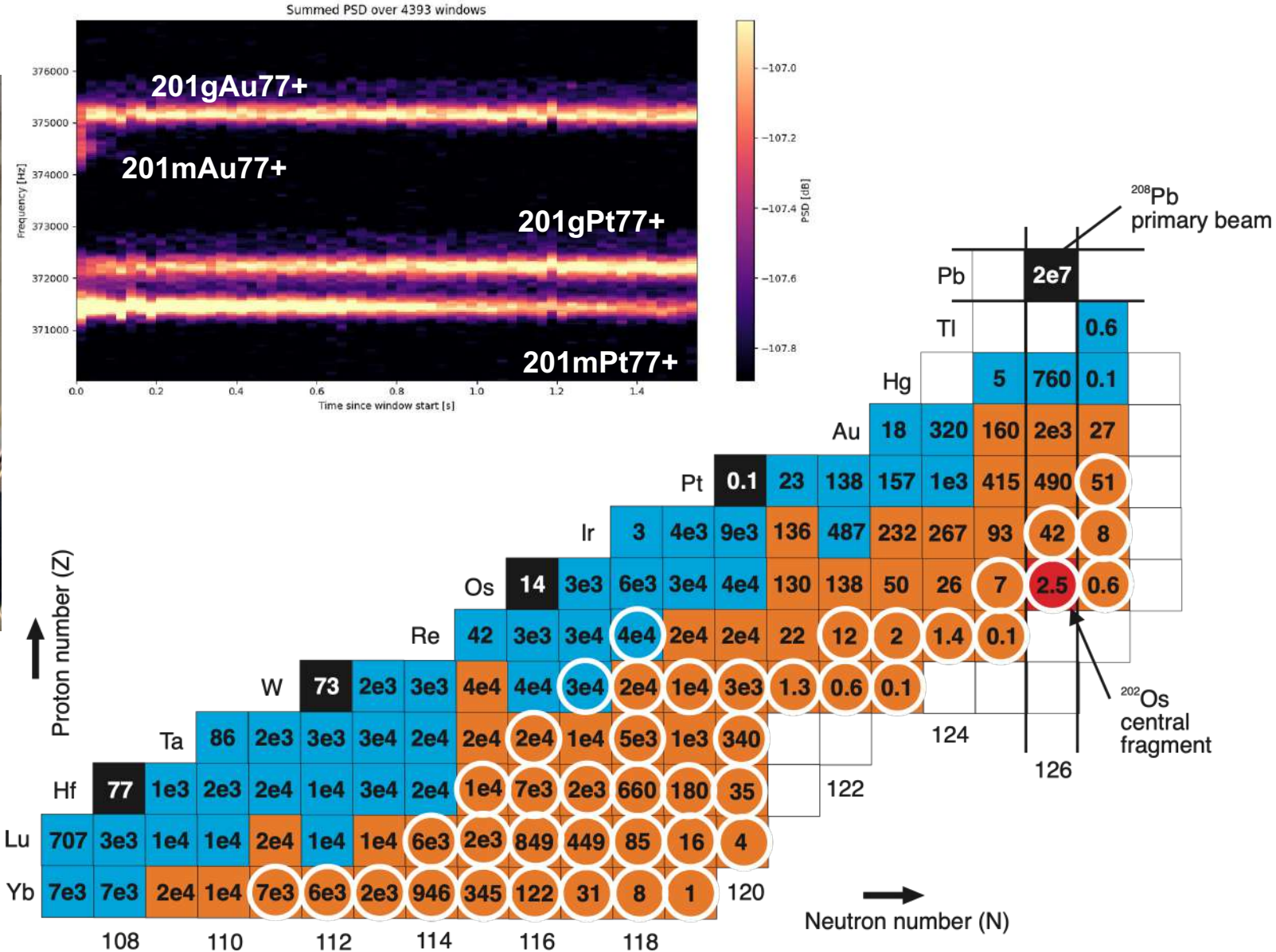

Isochronous mode



Accelerator Complex

Booster Ring:

- Circumference: 569 m
- Rigidity: 34 Tm
- Accumulation
- Cooling & acceleration

High Energy Fragment Separator:

- Length: 192 m
- $B\rho = 25$ Tm

Spectrometer Ring

Spectrometer Ring:

- Circumference: 277.2 m
- Rigidity: 15 Tm
- Electron cooler
- Stochastic cooler

Ion Sources:

- a 45 GHz FCR
- a 28 GHz SECRA
- a 2.45 GHz ECR

Booster Ring

- Fast ramping operation
- Repetition rate: 3 Hz

iLinac

Superconducting Ion Linac:

- Length: 180 m
- Energy: 25 MeV/u ($^{238}\text{U}^{34+}$)
- CW mode: 10 μA with $A/Q=2\sim 5$
- Pulse mode: 1.0 emA with $A/Q=2\sim 7$

One day at the commissioning experiment at HIAF

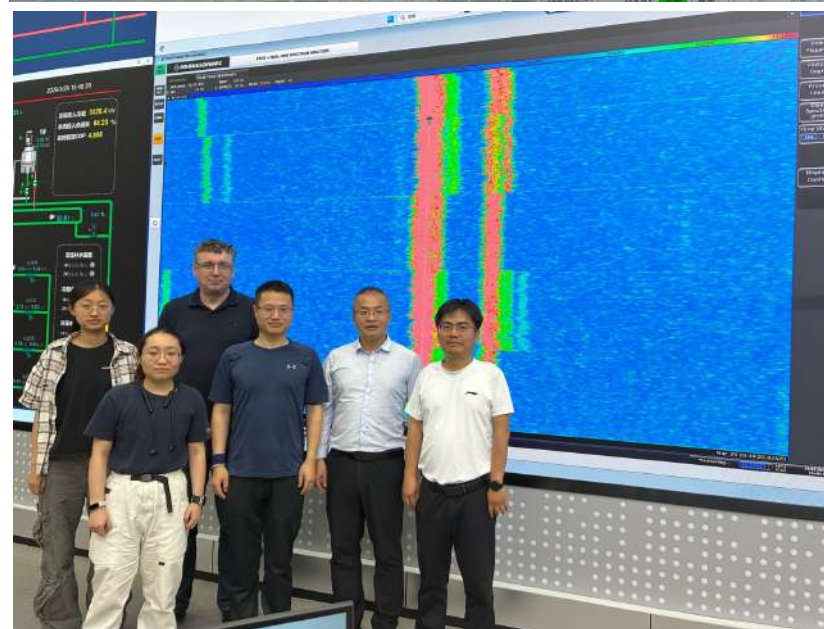
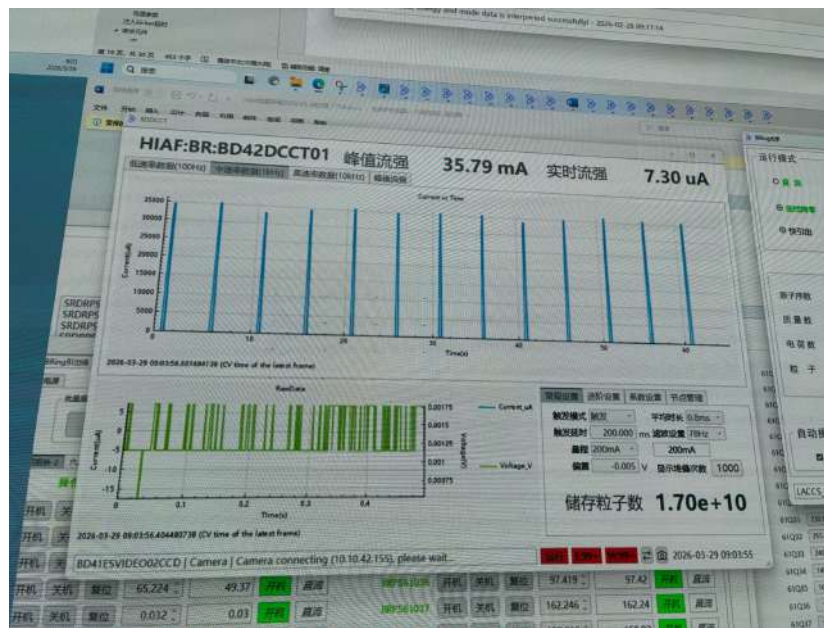
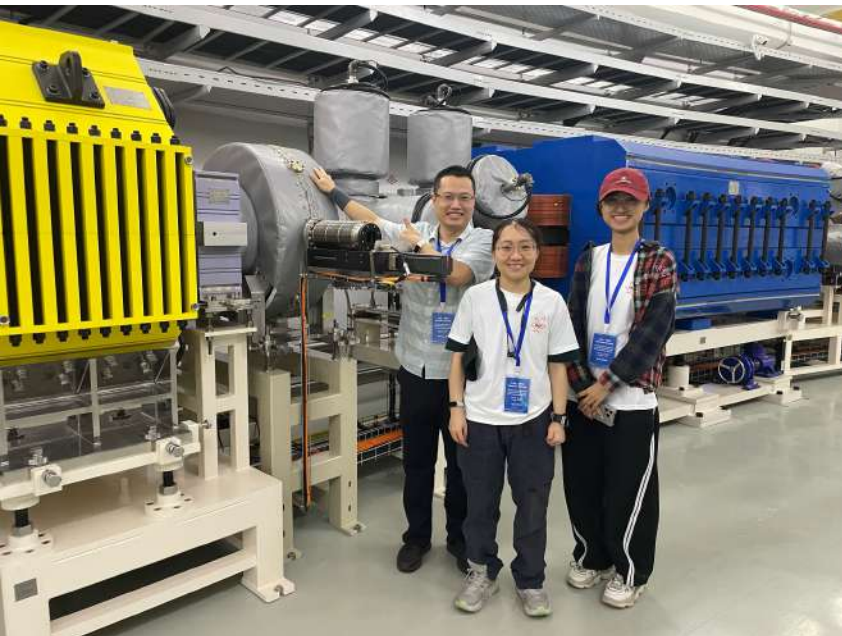



^{209}Bi 单核碎裂产物：时间分辨的肖特基频谱

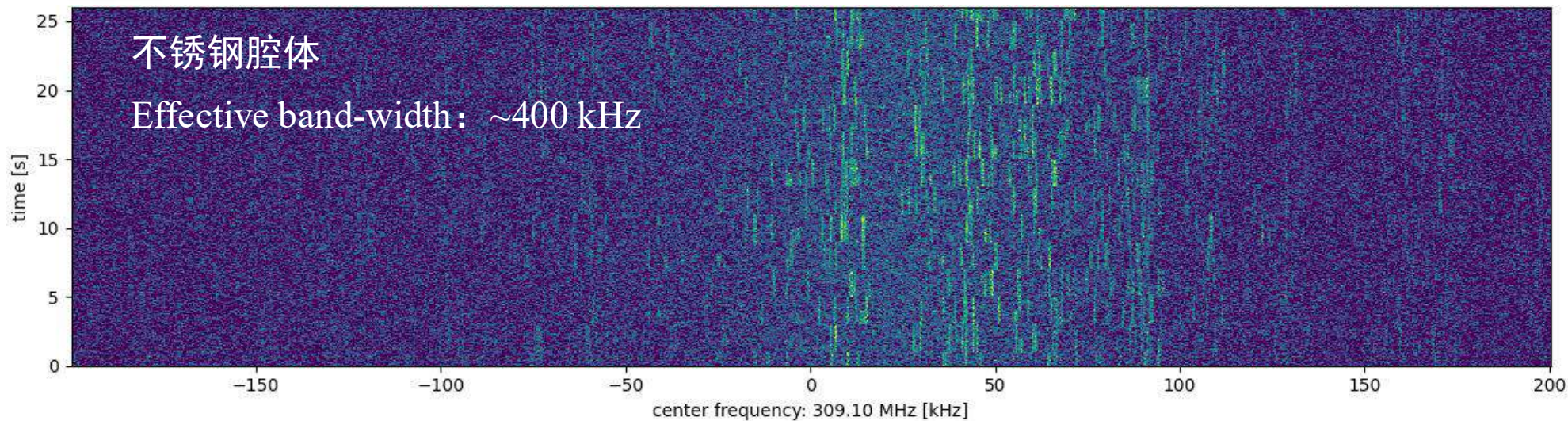

waterfall_from_Tek84_12.30.20.30.08-12.30.20.32.08
time for one frame: 11.823 [ms]

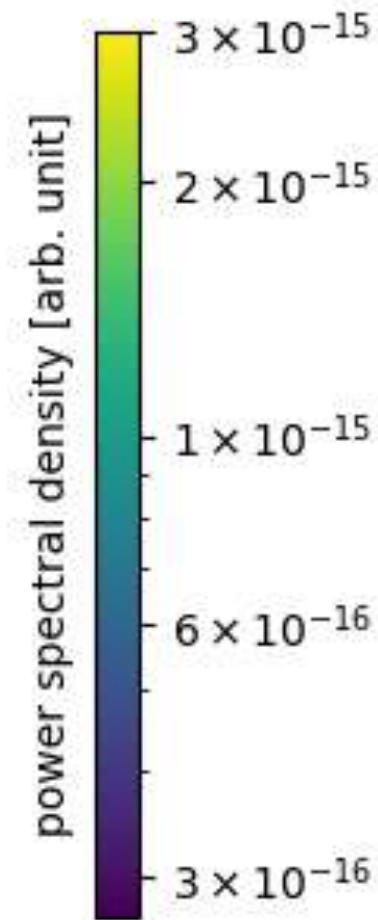
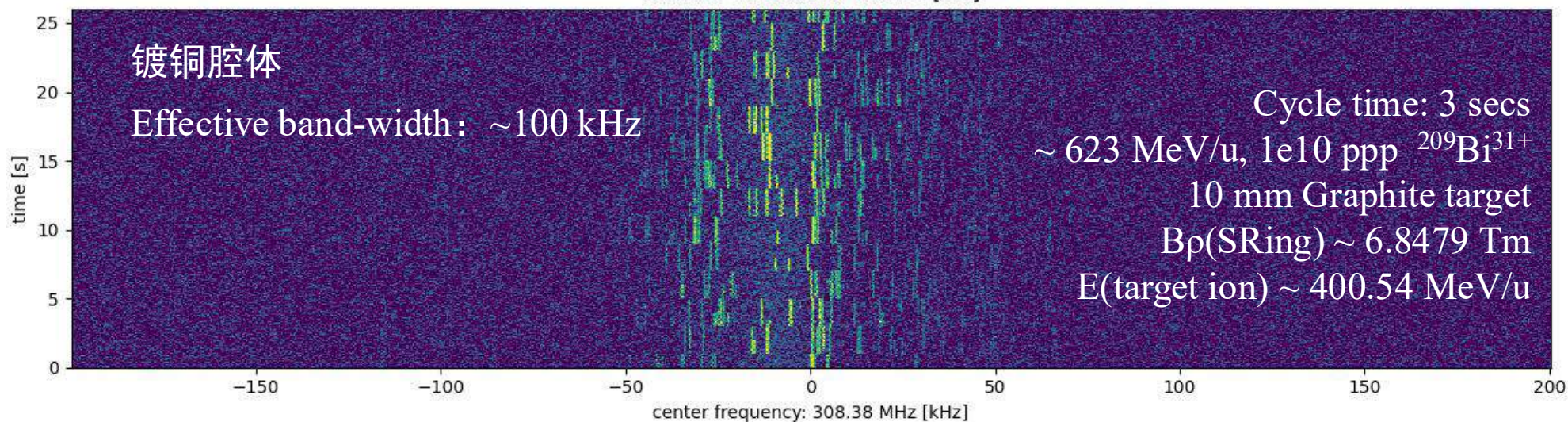



衰变事例：初步测试结果

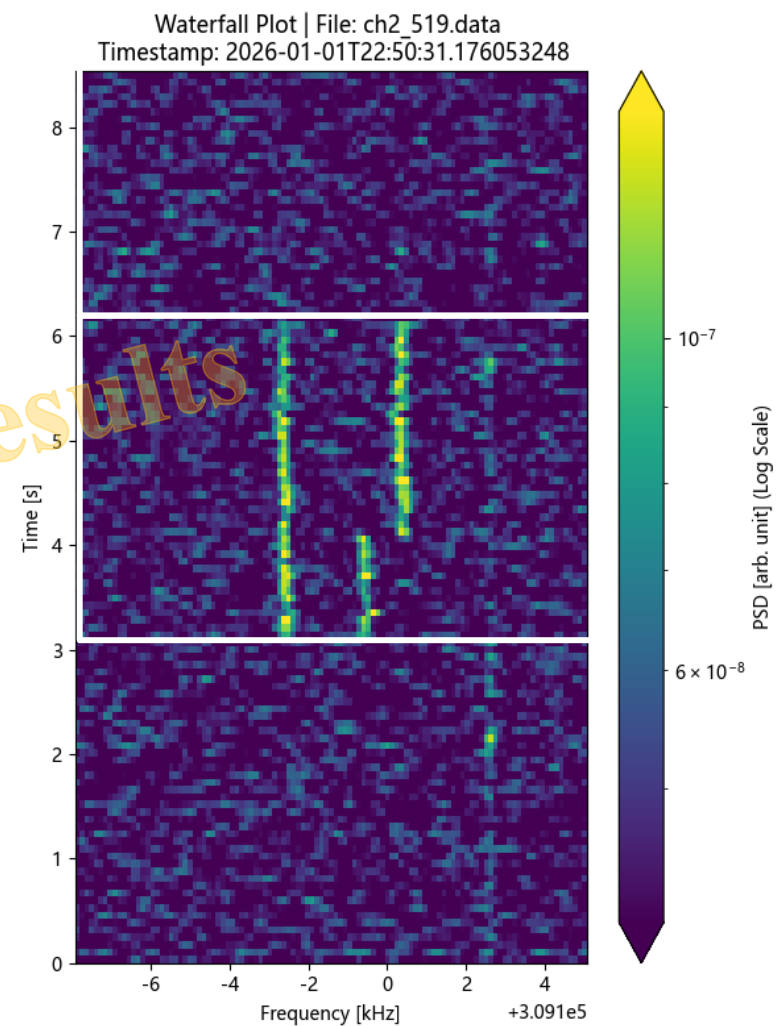
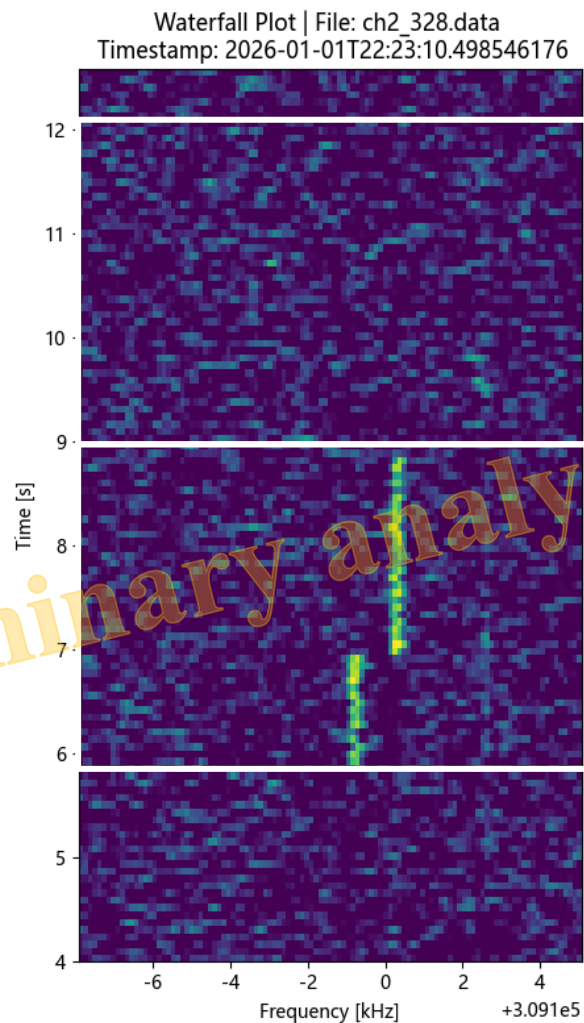
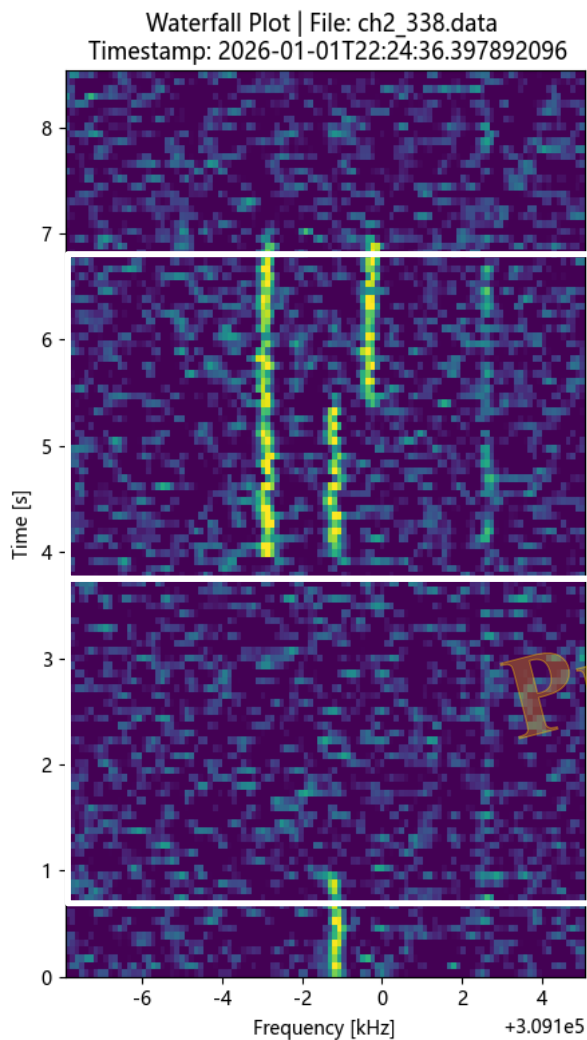

Preliminary analysis results



Combined Isochronous+Schottky+Position Mass Spectrometry at R3

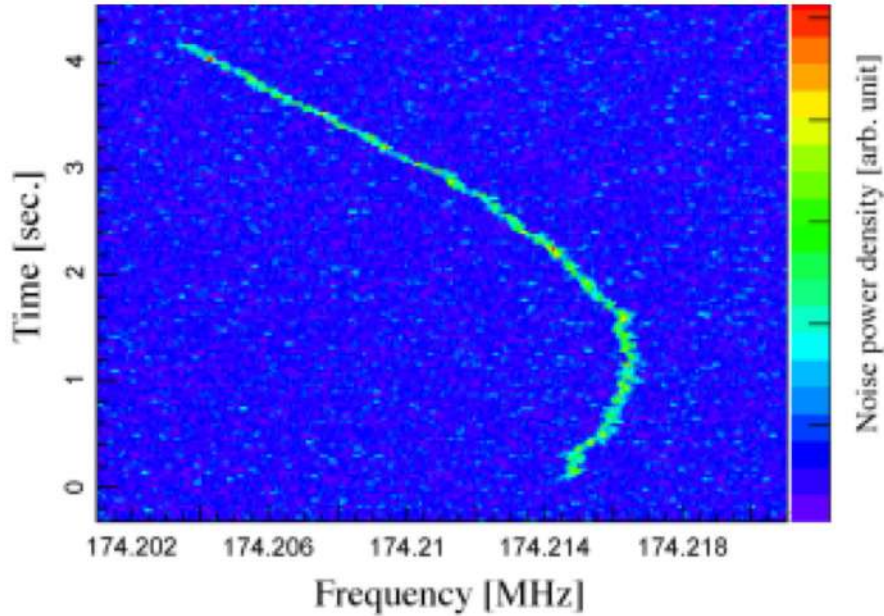
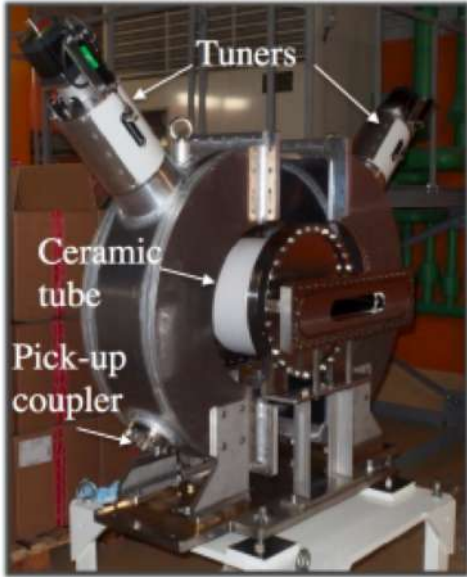

Isochronicity is fulfilled only for a limited range of velocities / mass-over-charge ratios of stored nuclides – so-termed “isochronous window”.

To correct for the non-isochronicity, either velocity or magnetic rigidity of each particle needs to be known.

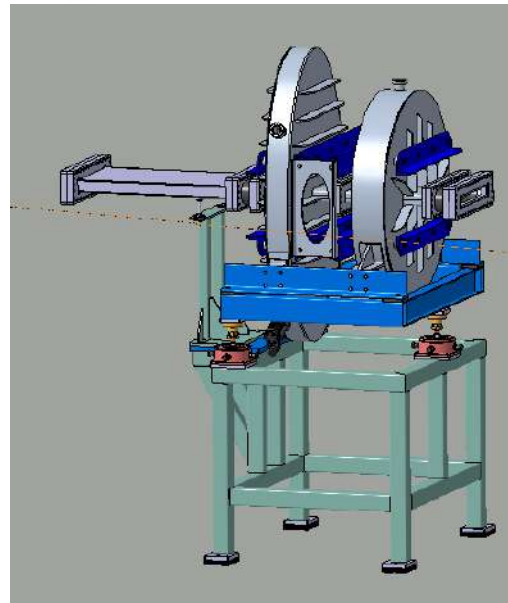

Why storage rings? - Versatile Capabilities

Masses and lifetimes of exotic nuclei

ERC CG ASTRUm

Nuclear Excitation by (target) Electron Capture

Nuclear Excitation by (free) Electron Capture

Hyperfine Quenching in few-electron ^{229}Th

ERC AG HIThor

Decays of highly charged ions (^{205}Tl , ^{111}Sn)

Transfer reactions

Long-lived isomeric states

Di-electronic recombination on exotic nuclei

Astrophysical reactions for BBN and

Novae, rp-, nup-, and p-processes

ERC SG ELDAR

Surrogate reaction studies

ERC AG NECTAR

Giant resonances

Electron-Ion scattering (future)

Neutron-induced reactions (future)

Why storage rings? - Versatile Capabilities

Masses and lifetimes of exotic nuclei

ERC CG ASTRUm

Nuclear Excitation by (target) Electron Capture

Nuclear Excitation by (free) Electron Capture

Hyperfine Quenching in few-electron ^{229}Th

ERC AG HIThor

Decays of highly charged ions (^{205}Tl , ^{111}Sn)

Transfer reactions

Long-lived isomeric states

Di-electronic recombination on exotic nuclei

Astrophysical reactions for BBN and
Novae, rp-, nup-, and p-processes

ERC SG ELDAR

Surrogate reaction studies

ERC AG NECTAR

Giant resonances

Electron-Ion scattering (future)

Neutron-induced reactions (future)

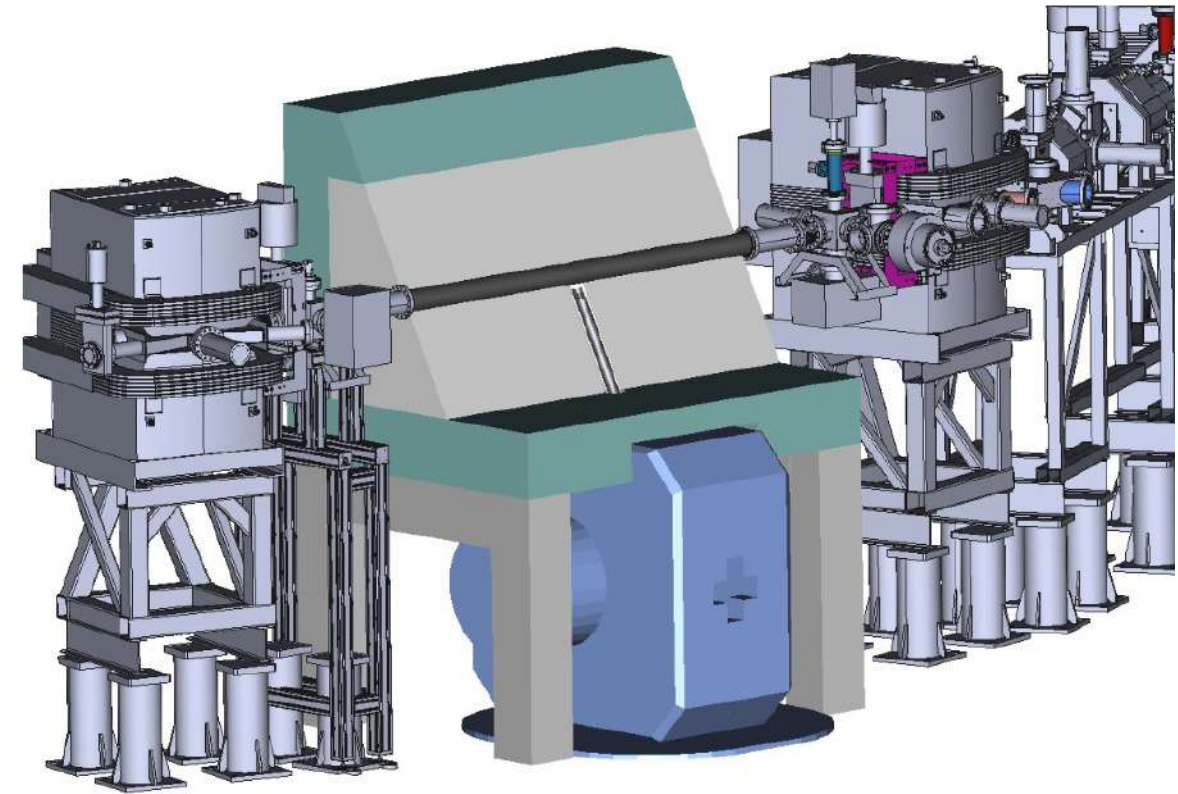

Courtesy: Ariel Tarifeno Saldivia

Free-neutron target at CRYRING

C. Domingo-Pardo et al. NRING-Project



Many thanks to our collaborators from all over the world !!!



We are supported by:



European Research Council
Established by the European Commission

HELMHOLTZ
RESEARCH FOR GRAND CHALLENGES



Bundesministerium
für Bildung
und Forschung