



Facility for Rare Isotope Beams Update



Thomas Glasmacher, FRIB Laboratory Director

glasmach@frib.msu.edu

15 April 2026



MICHIGAN STATE
UNIVERSITY



U.S. DEPARTMENT
of **ENERGY**

Office of
Science

Facility for Rare Isotope Beams

~700 employees, incl. 45 faculty, 130 graduate & 100 undergraduate students

- FRIB Project is a scientific user facility for the U.S. Department of Energy Office of Science with **first beam to an experiment in May 2022**
- Prior to FRIB, NSCL was funded by the U.S. National Science Foundation to operate a user facility for rare isotope research and education in nuclear science, nuclear astrophysics, accelerator physics, and societal applications

Groundbreaking 03/2014



Beneficial occupancy 03/2017

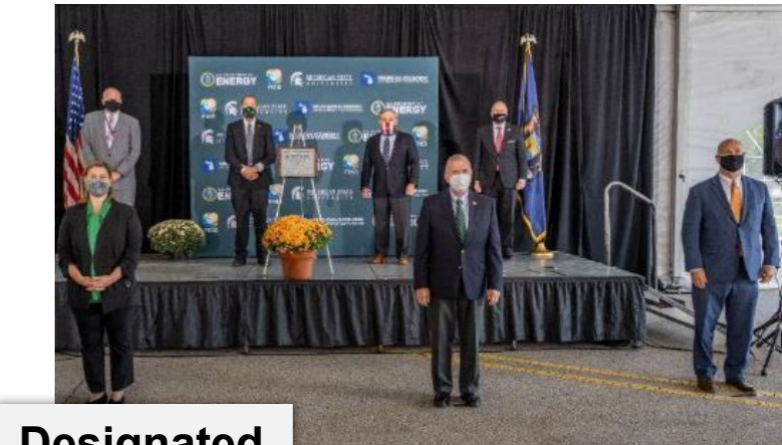
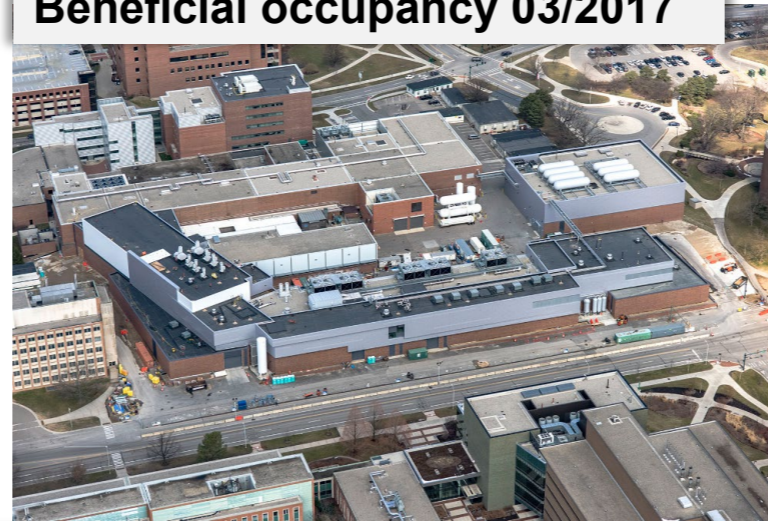

Designated as DOE-SC User Facility 09/2020

First rare isotopes produced and identified 12/2021

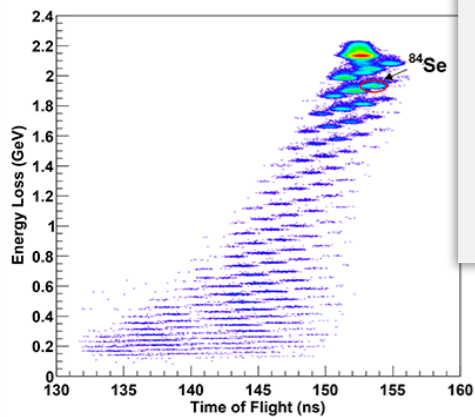

First science results published 11/2022

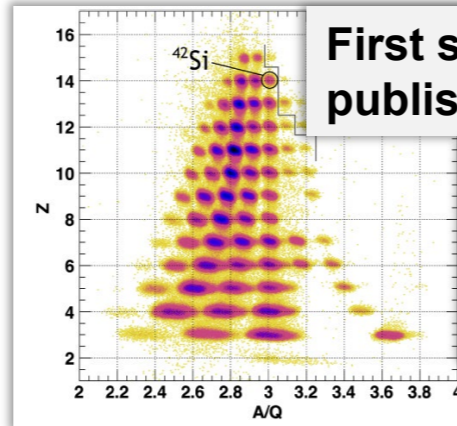

Featured in Physics Editors' Suggestion

Access by Michigan State University [Go Mobile](#)

Crossing $N = 28$ Toward the Neutron Drip Line: First Measurement of Half-Lives at FRIB

H. L. Crawford *et al.*
Phys. Rev. Lett. **129**, 212501 – Published 14 November 2022

PhysICS See Viewpoint: [Probing the Limits of Nuclear Existence](#)

1,800-Strong Engaged and Active User Community

fribusers.org

- Users organized and active in FRIB as part of independent FRIB Users Organization (FRIBUO)
 - Chartered organization with an elected executive committee
 - 1,801 members (1,116 U.S. members, 133 U.S. colleges and universities, 13 national laboratories, 38 U.S. states, 51 countries) as of 1 May 2025
 - 21 working groups engaging in FRIB science and instrumentation

FRIB serving the user community

- Of the total of 860 participants across 158 experiments and 23 countries from 154 institutions and companies across all user groups, the global FRIB scientific user community comprised:
 - 572 participants (198 of which were students) across 57 experiments
 - From the 119 non-proprietary FRIB experiments listed on the public website, 102 had proposals led by a contact spokesperson from a U.S. institution (**86%**). The remaining 17 proposals are led by institutions from the UK, Poland, Denmark, Spain, Australia, Canada, Japan, and South Korea.

FRIB can accommodate 30% of requested beam time

- Since 2022, FRIB has received 251 proposals for beam time use

Published results are available at frib.msu.edu/publications



2024 Annual Community Meeting at University of Tennessee Knoxville

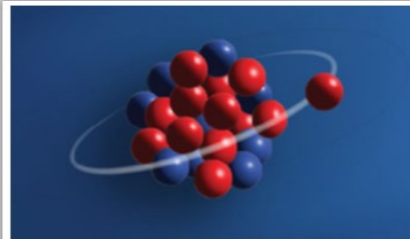
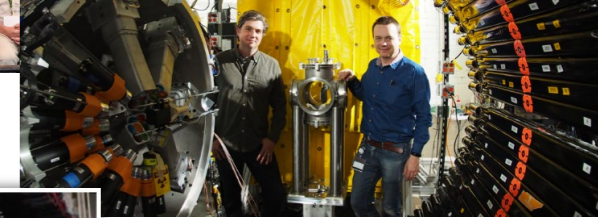

Researchers Obtain the First High-Precision Mass Measurement of Aluminum-22

The Facility for Rare Isotope Beams enables a high-precision mass measurement at the edge of the nuclear chart.

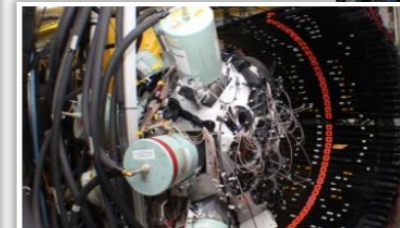

First Science Results from FRIB Published

Researchers have published the results from the first experiment at the Facility for Rare Isotope Beams, measuring the mass of 5 new half-lives, in Physical Review Letters.



Users build instruments

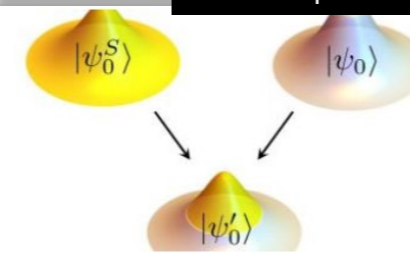

Making Difficult Quantum Many-Body Calculations Possible

Solving quantum many-body problems with wavefunction matching.



FRIB engages the next generation of scientists



Safely Ramping up Beam Power while Delivering Beams for Science: ^{238}U at 20 kW on Target

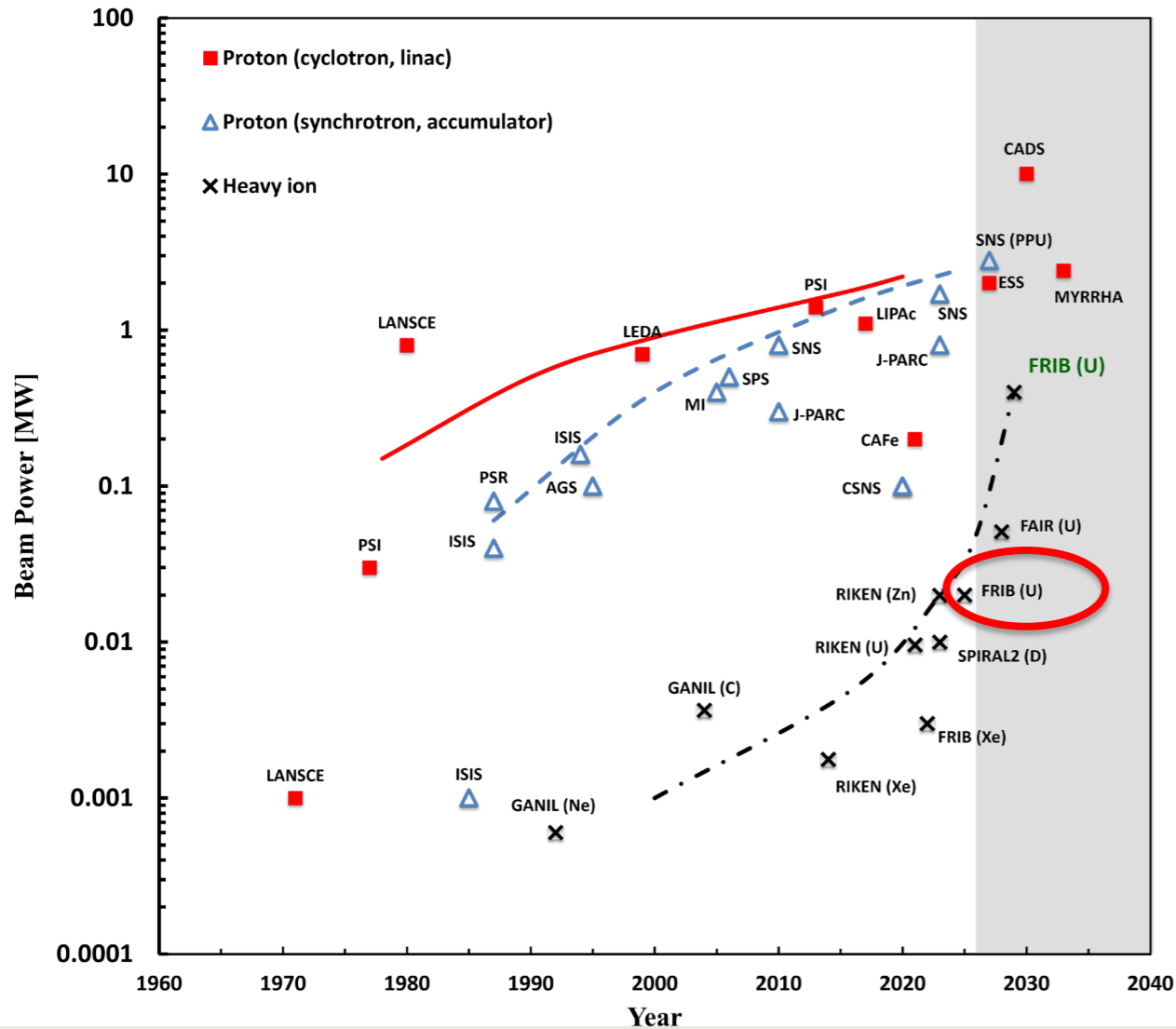

- From the start of user operation in May 2022 to the present, we raised the beam power from 1 kW to 30 kW
- There is another factor of 13 in beam power to the ultimate performance 400 kW
- We learn from current operation and extrapolate to higher beam power
 - Proceed safely and deliberately
 - Anticipate and avoid issues
 - Make improvements as we increase power
- Offering 30 kW operation in fall 2026



High (83% for ^{238}U) Stripping Efficiency with Five Charge-state Simultaneous Acceleration

- Routinely accelerating up to multiple charge states (five for ^{238}U , two for ^{86}Kr) simultaneously to enhance beam intensity and reduce controlled beam loss downstream of charge stripper

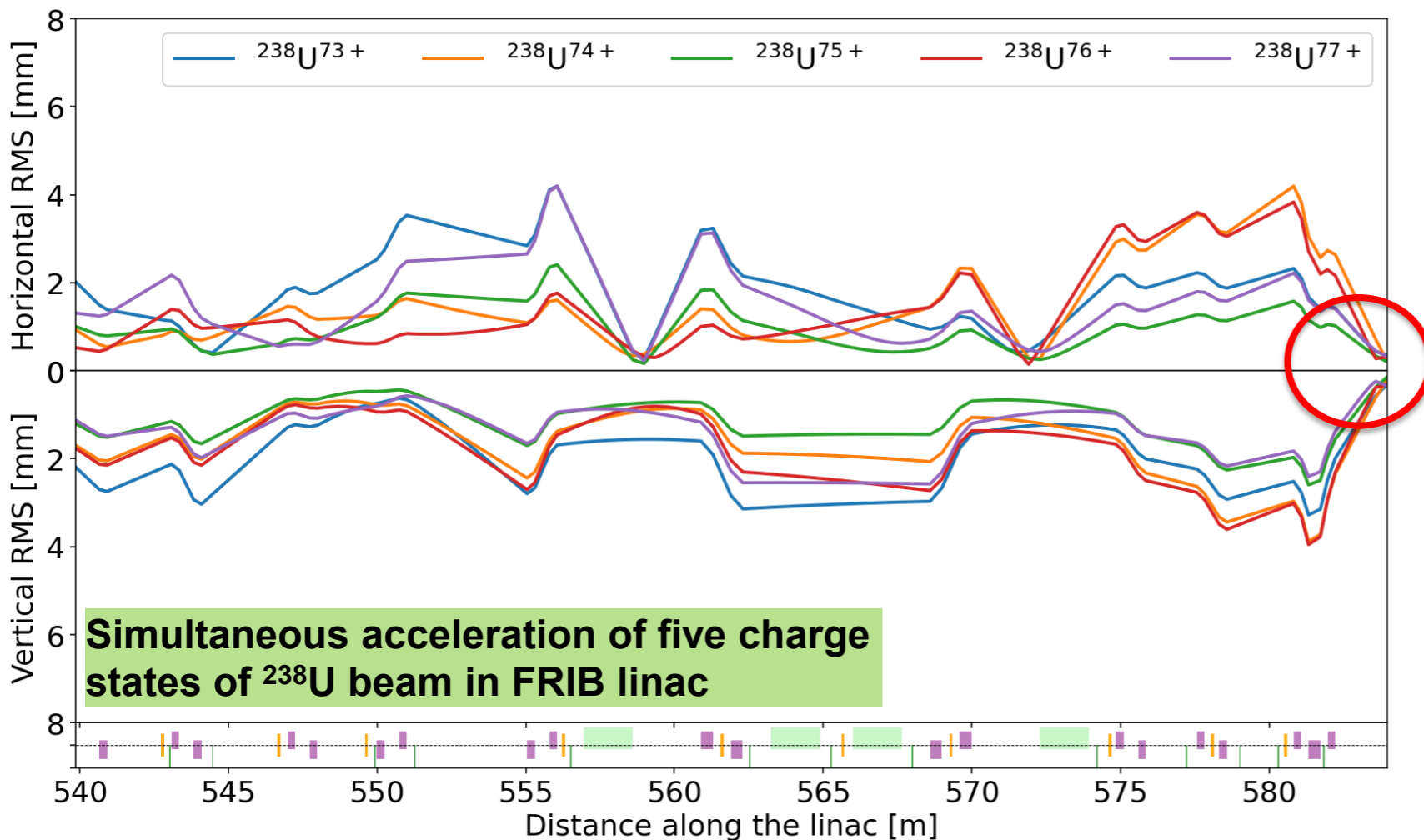

- Multi-charge-state beams tuned to overlap at specified locations
 - Production target (now)
 - Linac Segment 1 Charge stripper (future)
- Plan to accelerate two-charge-state beams in Linac Segment 1 (upstream of Charge Stripper)
 - Doubles beam power for same ECR performance

P. N. Ostroumov, *et al.*, *Phys. Rev. Lett.* **126**, 114801 (2021)

High-power Targetry Devices in Operation

Safe and Reliable Operation Key to Enabling Discovery

- Rotating, single-slice graphite target for rare isotope production
 - Absorbs ~ 25% beam power; accommodate small ($\varnothing \sim 1$ mm) beam size
- Static beam dump with shallow beam incident angle
 - Absorbs ~ 75% beam power; consideration of radio-activation in water and surroundings

Single-slice graphite production target

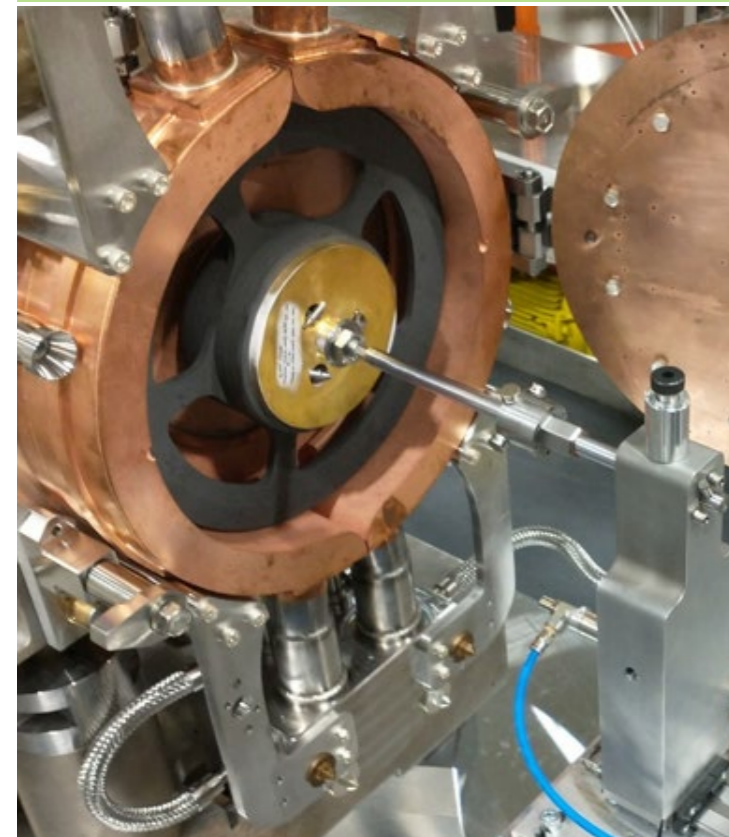

20 kW, 177 MeV/u ^{238}U beam on 2.1 mm thick graphite target rotating at 500 r.p.m.

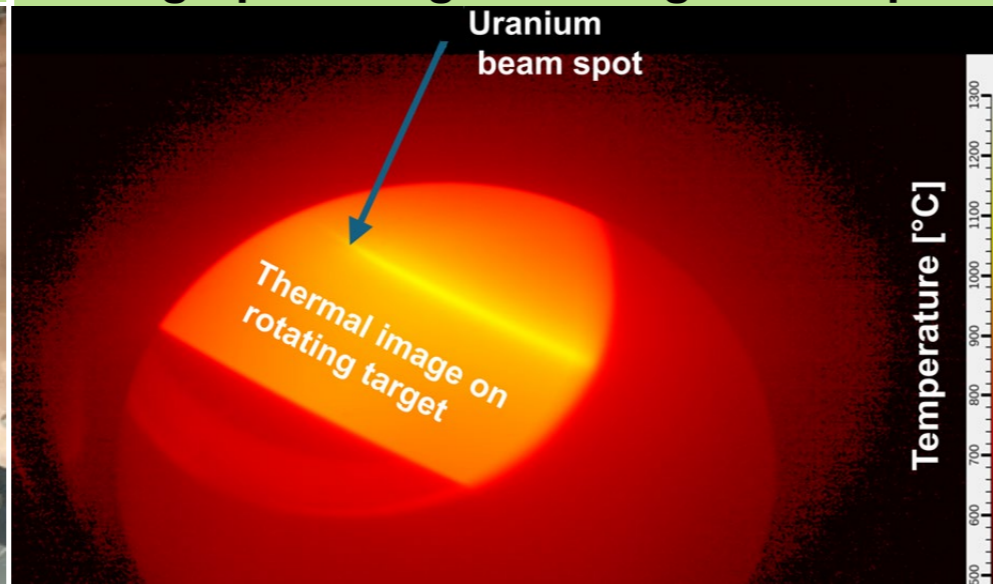

J. Song, *et al.*, HIAT'25, East Lansing, TUB01 (2025)

Static beam dump with 6° incident angle for incoming beam

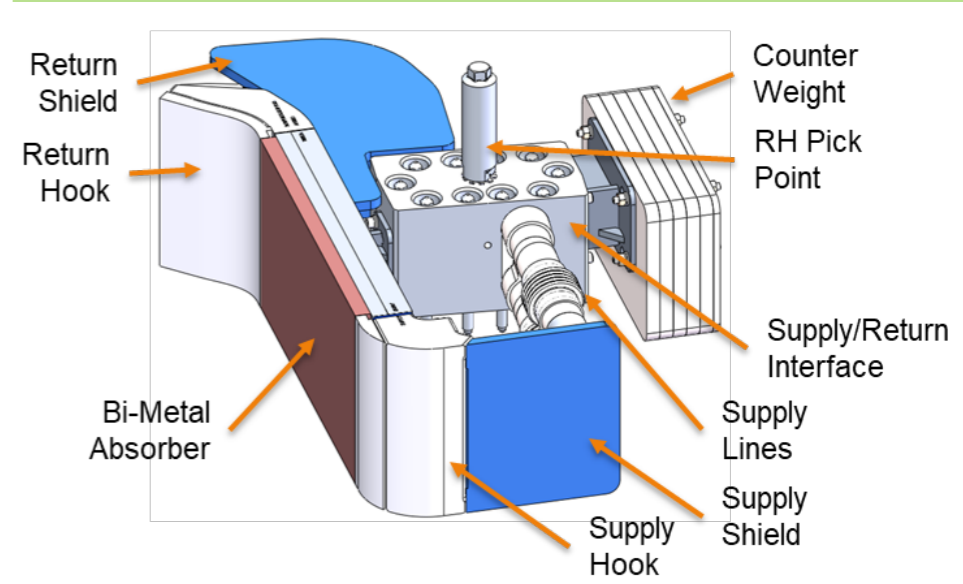

S. Miller, *et al.*, HIAT'25, East Lansing, TUP01 (2025)

More than 550 Rare Isotope Beams Delivered and 1,021 Experimenters Supported

- High-availability operation >90%
- Since the start of user operation in May 2022, FRIB has:
 - Delivered more than 550 rare isotope beams to experiments
 - Supported 1,021 participants, including 303 students, in 24 countries from 180 institutions and companies
 - » Participants, institutions, and companies may take part in multiple experiments
- Published results are available at frib.msu.edu/publications
- 27 primary beams from 21 isotopes demonstrated and available, see frib.msu.edu/beams
- FRIB is oversubscribed and can only accommodate a third of all requested beam time due to the large interest
 - Since 2022, FRIB has received 251 proposals for beam time use

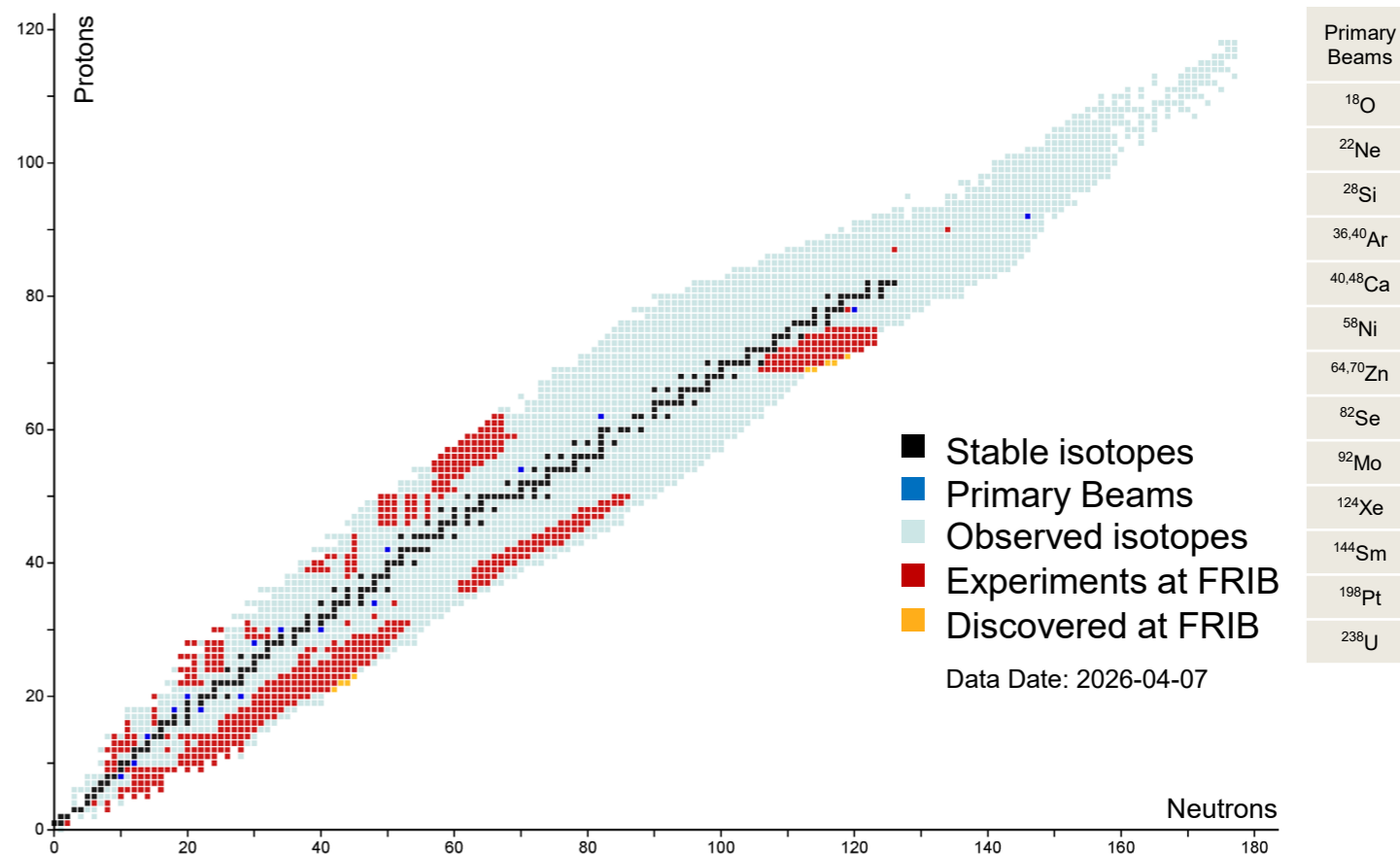

Highly Selective ARIS Fragment Separator

New isotopes discovered at FRIB

Featured in Physics

Editors' Suggestion

[Phys. Rev. Lett. 132, 072501 \(2024\)](#)

Observation of New Isotopes in the Fragmentation of ^{198}Pt at FRIB

O. B. Tarasov, A. Gade, K. Fukushima, M. Hausmann, E. Kwan, M. Portillo, M. Smith, D. S. Ahn, D. Bazin, R. Chyzh, S. Giraud, K. Haak, T. Kubo, D. J. Morrissey, P. N. Ostroumov, I. Richardson, B. M. Sherrill, A. Stolz, S. Watters, D. Weisshaar, and T. Zhang

Phys. Rev. Lett. **132**, 072501 (2024) – Published 15 February 2024

Physics: Five New Isotopes Is Just the Beginning

Less than a year after its opening, the Facility for Rare Isotope Beams produced five never-before-seen isotopes for observation, a success that researchers say highlights the discovery potential of the facility.

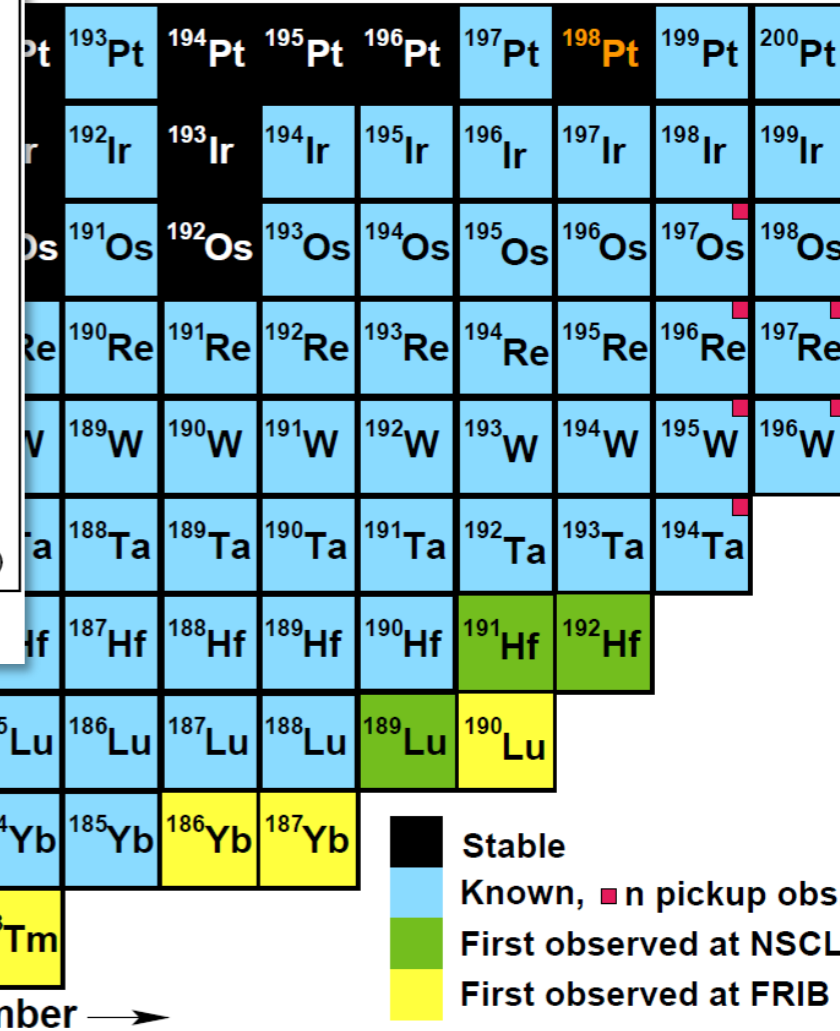
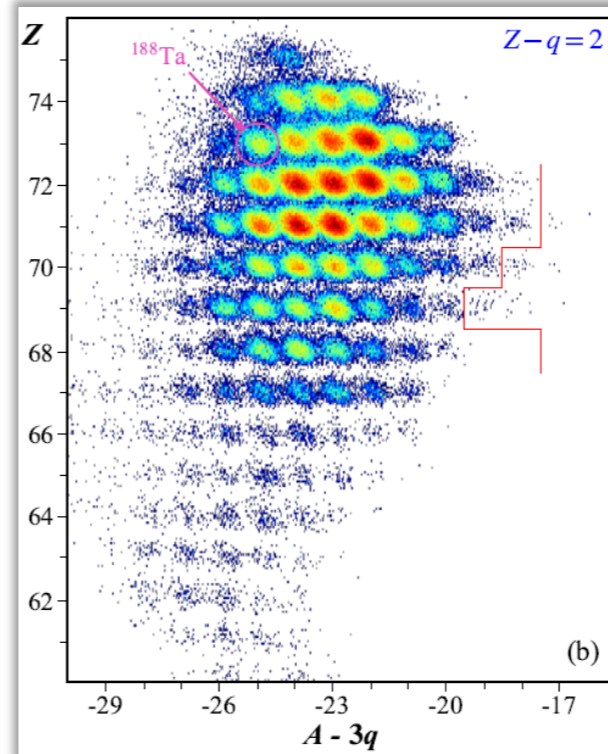
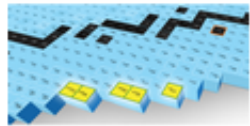

FEBRUARY 27, 2024 | 5 MIN READ

Weird Lab-Made Atoms Hint at Heavy Metals' Cosmic Origins

Researchers have created ultraheavy versions of elements that have never existed before on Earth

SCIENTIFIC AMERICAN

FRIB made 5 never-before-seen isotopes of the elements thulium, ytterbium, lutetium



Discoveries Enabled by Beam Power, Selective Fragment Separation, Sensitive and Efficient Instruments

- M. Pfuetzner, C. Mazzocchi *et al.* (2025)
 - 2011: 6 events of ^{48}Ni at NSCL
 - 2021: 8 events of ^{48}Ni observed at GANIL
 - 2025: >100 events of ^{48}Ni recorded at FRIB



ELSEVIER

Contents lists available at [ScienceDirect](https://www.sciencedirect.com)

Progress in Particle and Nuclear Physics

journal homepage: www.elsevier.com/locate/ppnp

Review

Two-proton emission and related phenomena

M. Pfützn^{a,*}, I. Mukha^b, S.M. Wang^{c,d}

^a Faculty of Physics, University of Warsaw, Pasteura 5, PL-02-093 Warszawa, Poland

^b GSI Helmholtzzentrum für Schwerionenforschung, 64291 Darmstadt, Germany

^c Key Laboratory of Nuclear Physics and Ion-beam Application (MOE), Institute of Modern Physics, Fudan University, Shanghai 200433, China

^d Shanghai Research Center for Theoretical Nuclear Physics, NSFC and Fudan University, Shanghai 200438, China

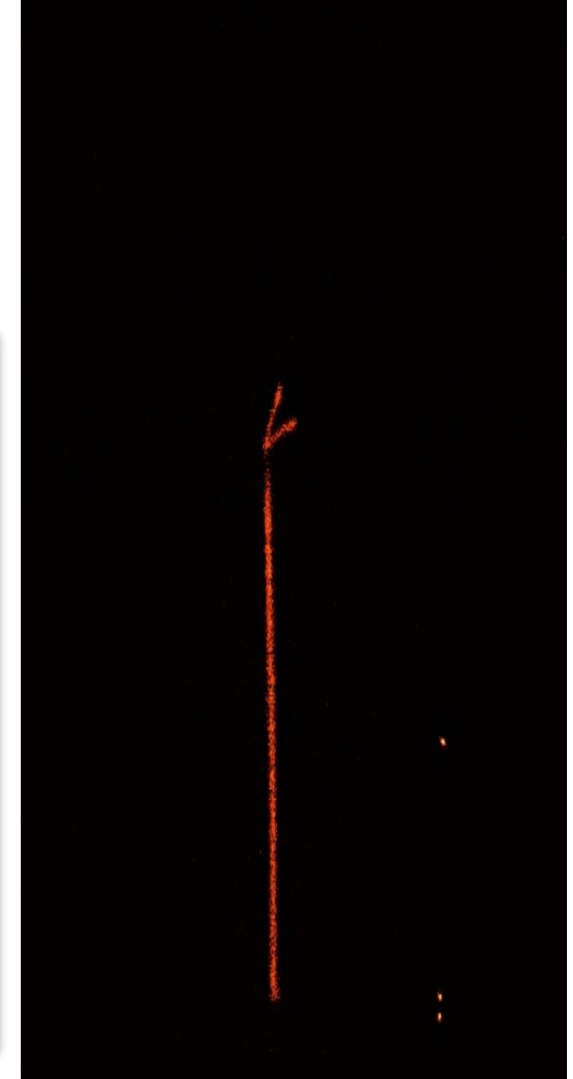
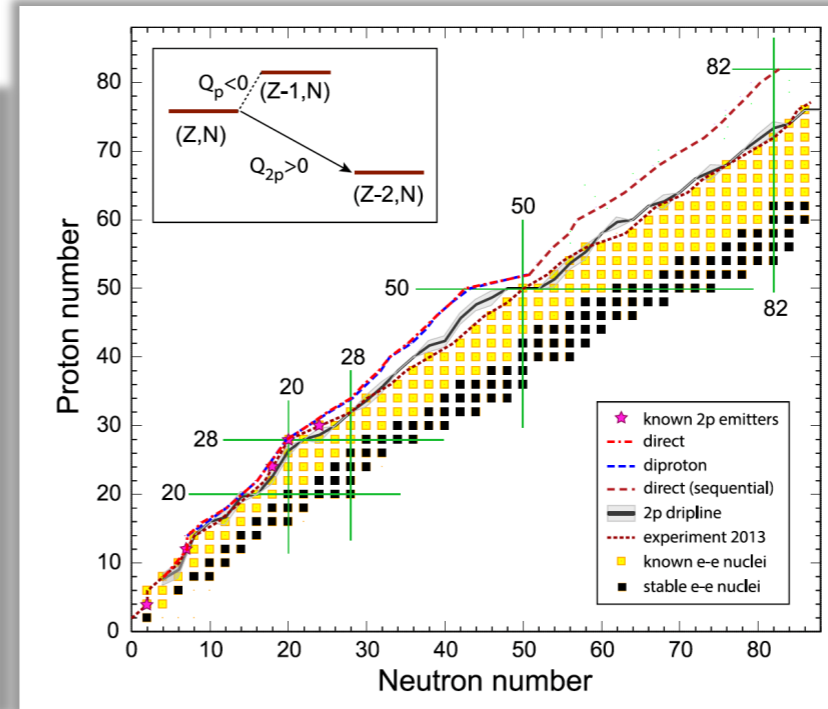

Facility for Rare Isotope Beams
U.S. Department of Energy Office of Science | Michigan State University
640 South Shaw Lane • East Lansing, MI 48824, USA
frib.msu.edu

Applied Isotope Harvesting Program at FRIB Started

- Isotope harvesting at FRIB started with *harvesting in a solid*

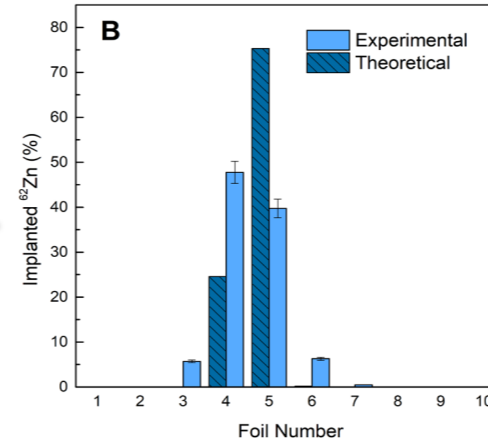
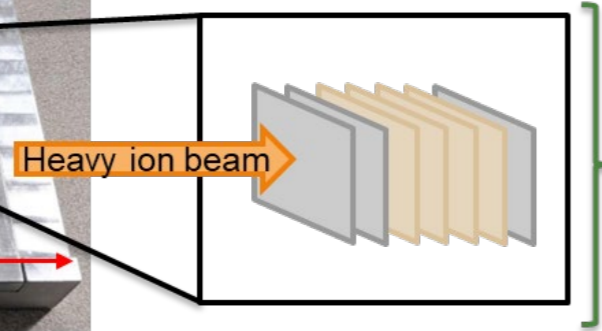
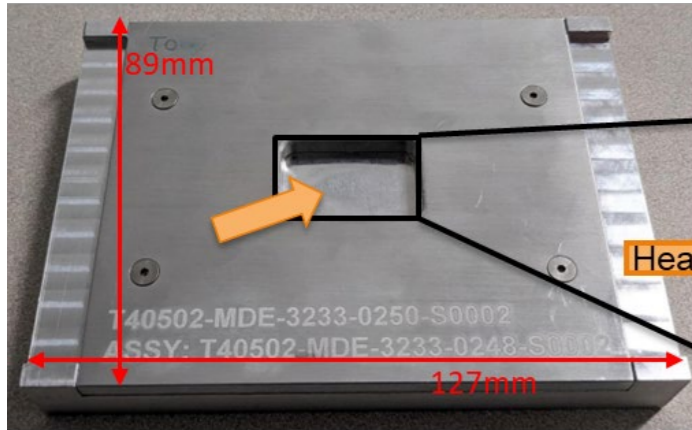

- Solid catcher to capture 2nd beam fragments
- Development of solid harvesting approach using 2nd fragments of ^{47}Ca , ^{62}Zn , ^{197}Pt , which are all of interest for nuclear medicine
- Ideal to harvest radionuclides with challenging aqueous chemistry

- Isotope harvesting at FRIB presents the unique opportunity to recover unused beam fragments for future use through commensal harvesting

- DOE-IP and MSU have invested in isotope harvesting, new faculty, and workforce development
- Experiments with dedicated aqueous harvester scheduled



High Rigidity Spectrometer (HRS) Being Constructed

- The High Rigidity Spectrometer (HRS) will enable best use of FRIB's high rigidity rare isotope beams for in-flight reaction experiments
- <https://hrs.lbl.gov/>
- Multiple ion-optical modes optimize different experiments
 - Achromatic mode
 - Dispersion matching mode
 - Achromatic mode with intermediate beam image
- HRS includes a High Transmission Beam Line (HTBL) and a Spectrometer (SPS)
 - HRS-HTBL being constructed
 - » Early Completion CD-4 in September 2028
 - » Start of 0-degree science program in 2029
 - HRS-SPS finalizing design

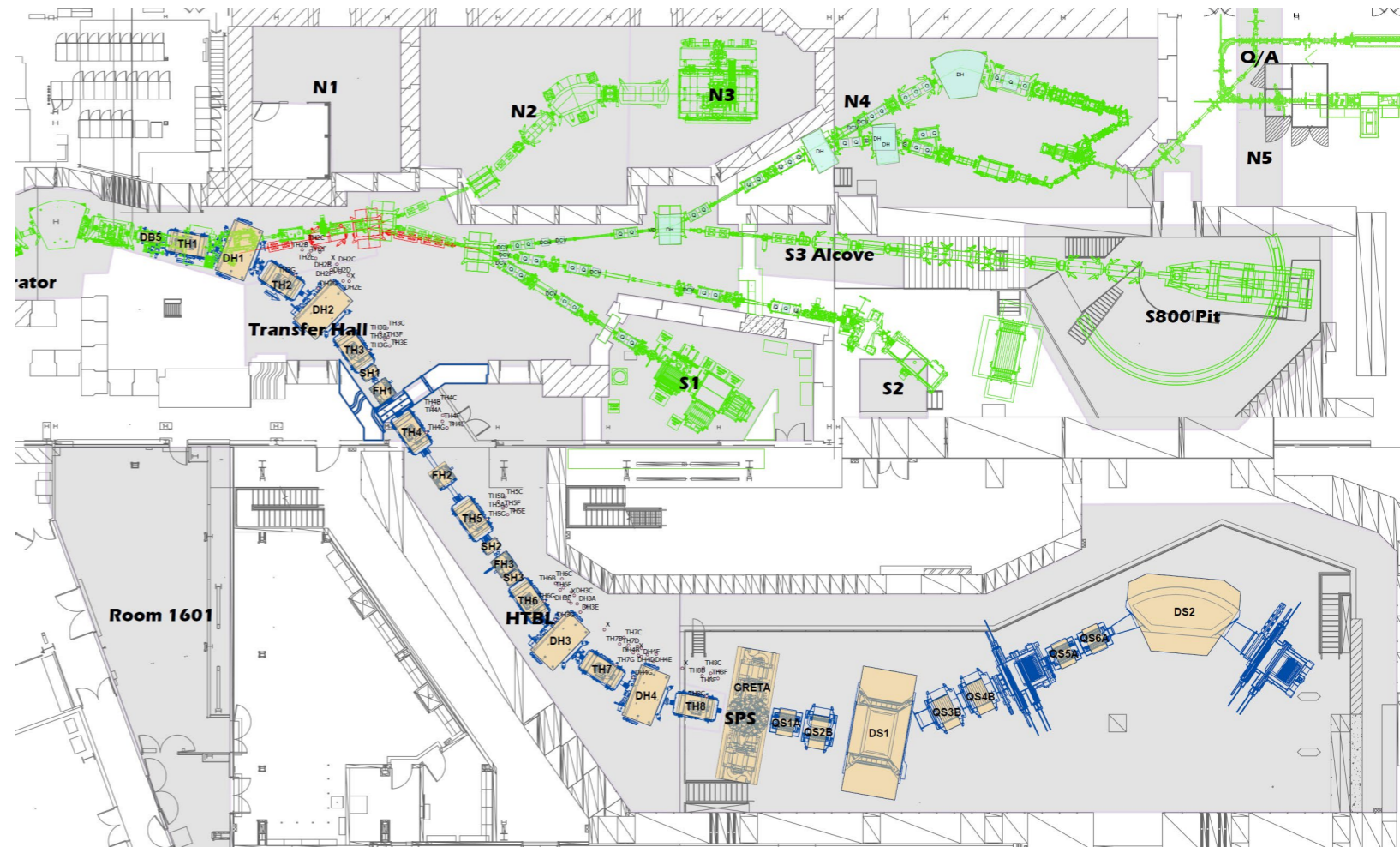

Experimental Areas for User Experiments

Added Areas for Fast Beam Experiments in 2025

Fast Beam Area (starting 2025)

- **New S1** – FRIB Decay Station initiator
- **New S2** - Sweeper Magnet/MONA
- S3 - S800

Stopped Beam Area

- BECOLA/RiSE, LEBIT

ReAccelerator Area

- ReA3 - SECAR
- ReA6 - SOLARIS

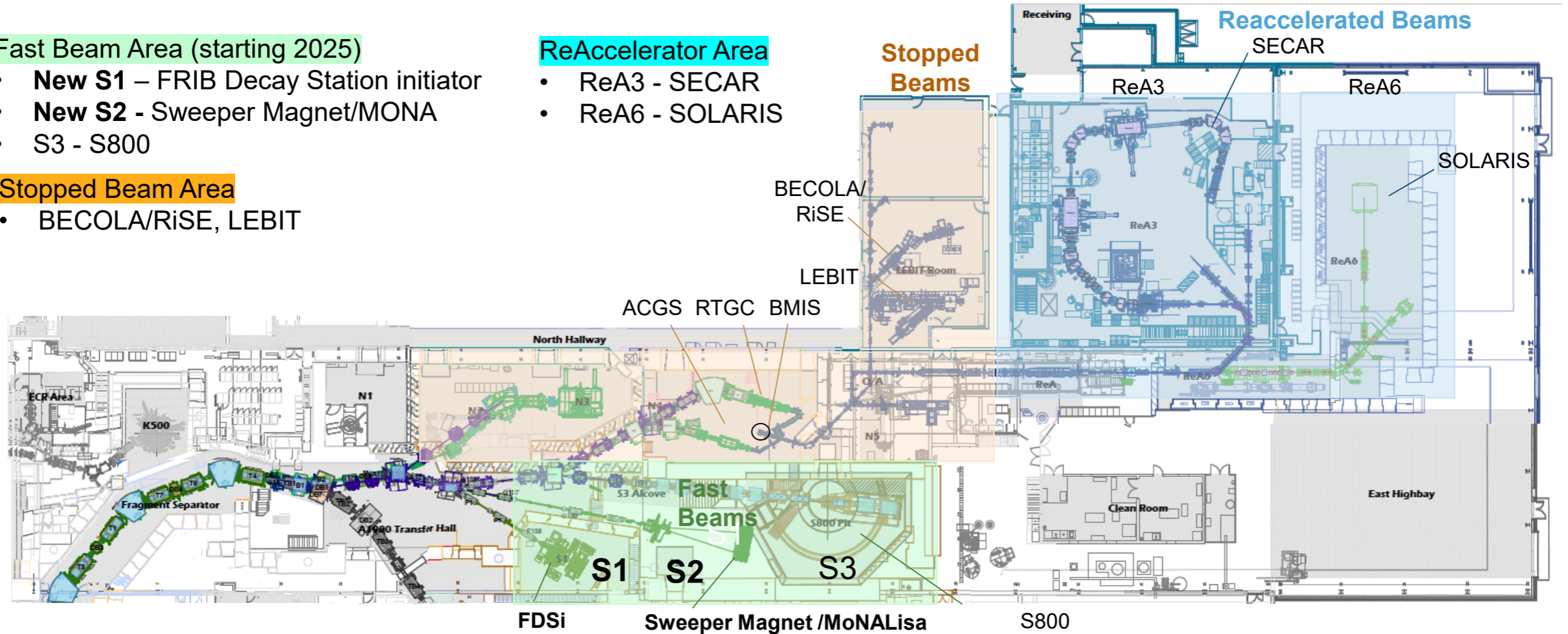

FDSi - FRIB Decay Station Initiator; RTGC - Room Temperature Gas Cell; ACGS - Advanced Cryogenic Gas Stopper; BMIS - Batch Mode Ion Source



FRIB400: Extend Scientific Reach and Discovery Potential

- Doubles linac beam energy (to 400 MeV/u for uranium) by adding 11 cryomodules, each containing 5 ($\beta = 0.65$) cavities at 644 MHz
 - Fill reserved slots in FRIB tunnel; expand cryo-distribution
- R&D and design: in progress

A. Gade *et al.*, Eds., "FRIB400: The Scientific Case for the 400 MeV/u Energy Upgrade of FRIB", Jun. 2019, updated Feb. 2023.

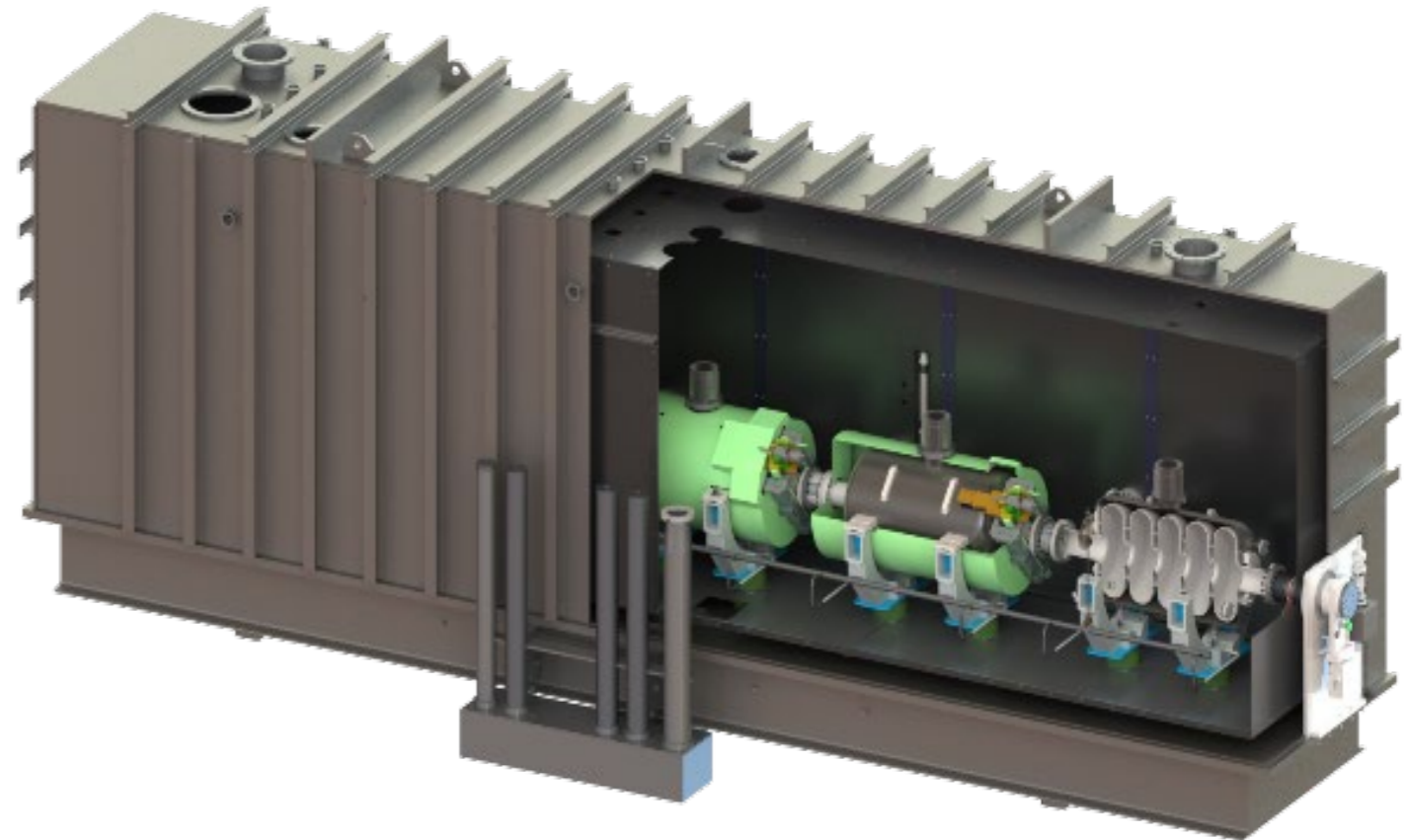
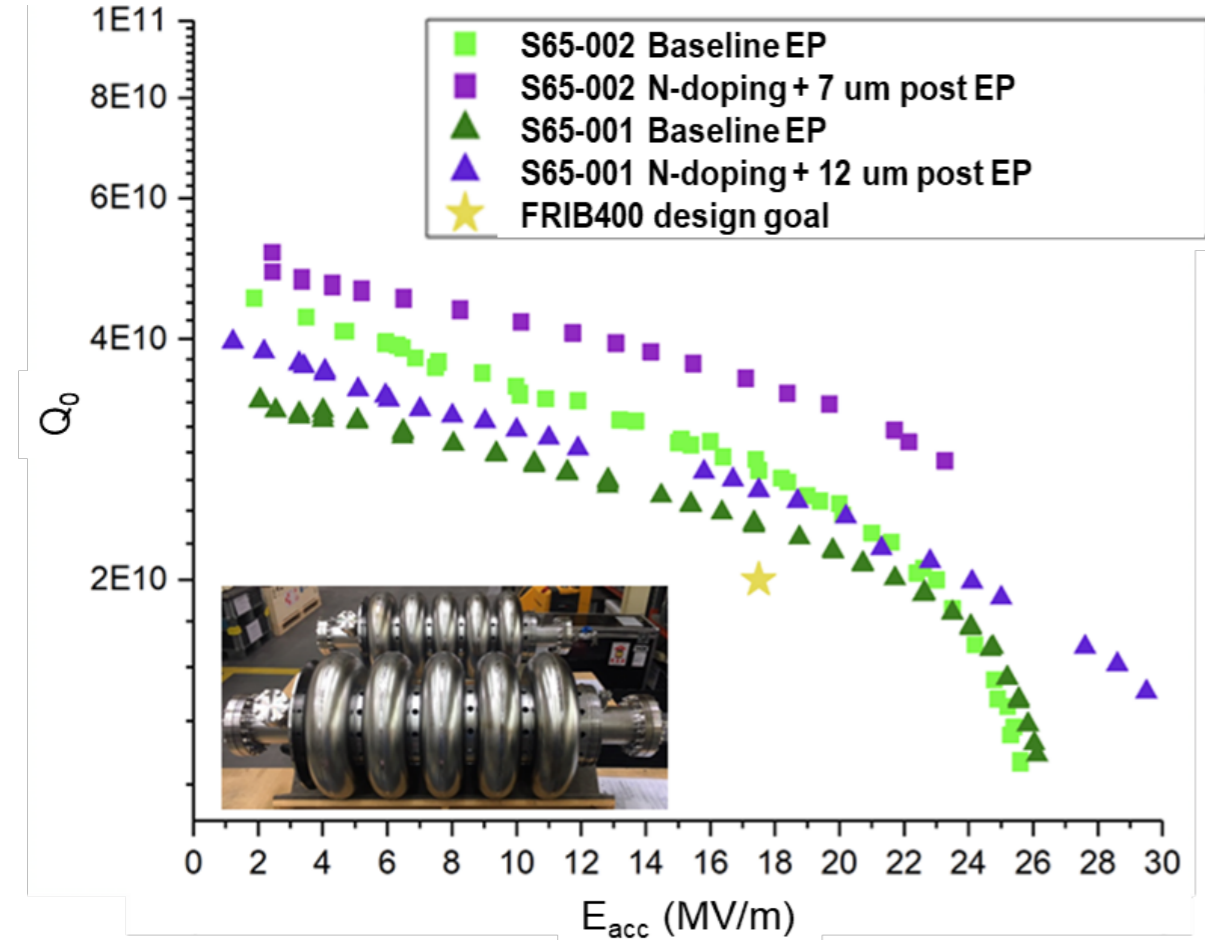

Training the Next Generation of Scientists and Engineers

- MSU nuclear physics graduate program top-ranked for 29 years
- Between 2018–2024, MSU awarded 17% of nuclear physics doctorate degrees in U.S.
- Leadership in implementing best practices for student mentoring and supporting excellence is impactful:
 - Strong progress in educating students with demographic backgrounds that resemble those of U.S. population
 - Median time to PhD is 5.3 years (U.S. median is 6 years)
 - PhD completion rate is 81% (U.S. average is ~60%)
- Undergraduate students strongly involved with forefront research



Graduating student careers (since 2011)

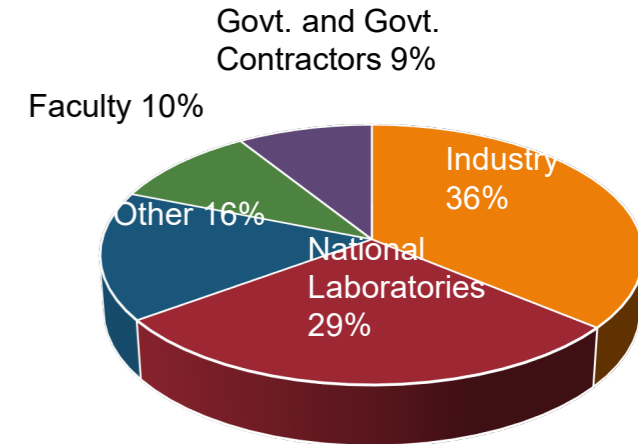

as of September 2024

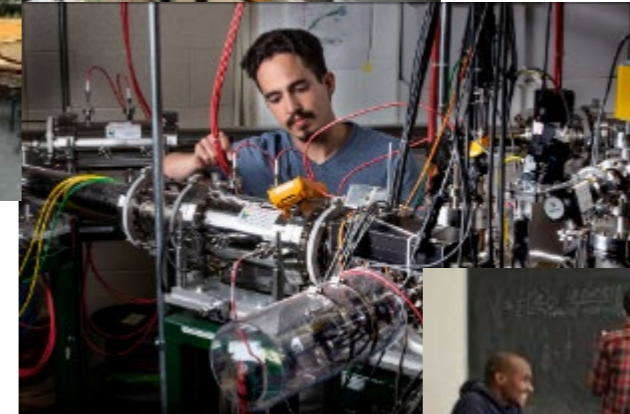

FRIB Is Grateful to Its Collaborators and Partners

- **ANL**
 - Liquid lithium charge stripper
 - Beam dynamics verification; $\beta=0.29$ HWR processing and testing; SRF tuner validation; beam dump; SRF components development
 - RF couplers for multi-gap buncher
 - SOLARIS
- **BNL**
 - Plasma window & charge stripper, physics modeling, magnets
- **FNAL**
 - Diagnostics, SRF processing
- **JLab**
 - Cryoplant; cryodistribution design & prototyping
 - Cavity hydrogen degassing; e-traveler
 - HWR processing & certification
 - QWR and HWR cryomodule design and engineering support for production
- **LANL**
 - Proton ion source
- **LBNL**
 - ECR coldmass; beam dynamics
- **MIT**
 - CRIS
- **ORNL**
 - Remote handling, diagnostics; large-vessel vacuum, cryoplant controls
 - FDSi
- **SLAC**
 - Cryogenics, SRF multipacting, physics modeling



- **RIKEN**
 - Helium gas charge stripper
- **TRIUMF**
 - Beam dynamics design, physics modeling SRF, QWR etching
- **INFN**
 - SRF technology, Instruments
- **CNRS**
 - International Research Laboratory
- **KEK**
 - SRF technology, SC solenoid prototyping
- **UKRI-STFC**
 - Instruments
- **MP**
 - Magnets
- **Budker Institute, INR Institute**
 - Diagnostics
- **Tsinghua Univ. & CAS**
 - RFQ
- **ESS**
 - Accelerator physics
- **DTRA**
 - RFQ power supply
- **CSNSM-JaNNUS**
 - Nuclear recoil damage to materials
- **RaDIATE**
 - Nuclear recoil damage to materials
- **GANIL**
 - Rare isotope physics, target development
- **GSI**
 - Rare isotope physics, fragment separators

Summary

- FRIB started scientific user operation in May 2022
- 1,800 users engaged and producing impactful science
- Have delivered 550 rare isotope beams to 1,021 Experimenters
- FRIB superconducting radio-frequency linear accelerator and other systems operating with >90% availability
- Cryoplant operating since 2018 at 4K and 2K
- Ramped up power by factor of 30 without issues, in fall at 30 kW
Deliberate plans to safely ramp up power further
- Training the next generation of Scientists and Engineers
- High Rigidity Spectrometer being constructed
- Looking Ahead to FRIB400 Energy upgrade to extend discovery potential

