

Opportunities in reaction studies with re-accelerated rare isotope beams at ARIEL

Panel discussion

Ben Kay, Argonne (USA) ... an offer/suggestion

Alessia Di Pietro, LNS (Italy) ... a suggestion

Beatriz Fernández Domínguez, USC (Spain) [online ... ideas]

Wilton Catford, Surrey (UK) ... five things to say

ARIEL WORKSHOP

- Active target systems (See T. Roger & Y. Ayyad) : Essential for maximizing luminosity with rare beams
- Vertex reconstruction and thick-target operation
Enables measurements otherwise impossible with conventional setups

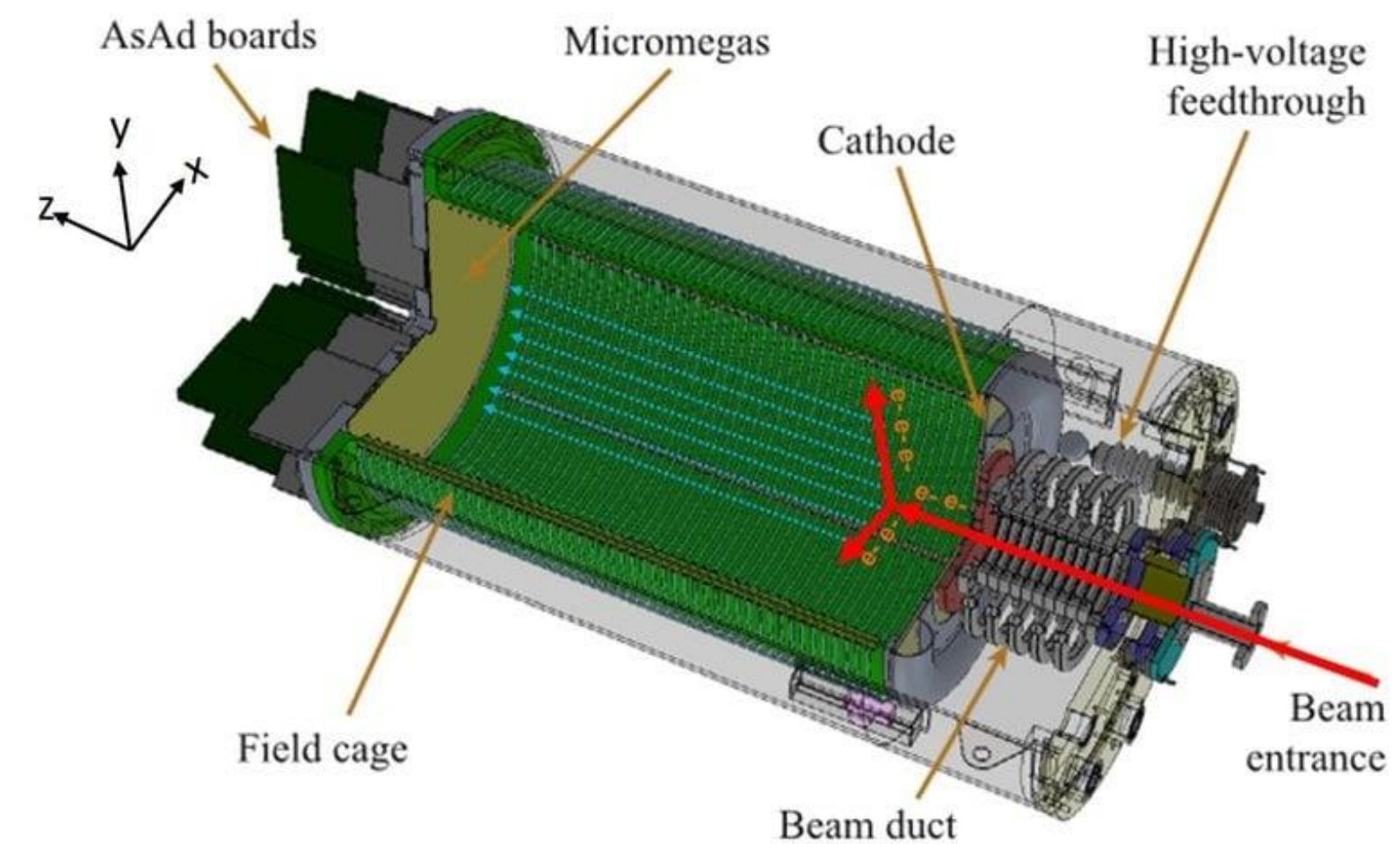
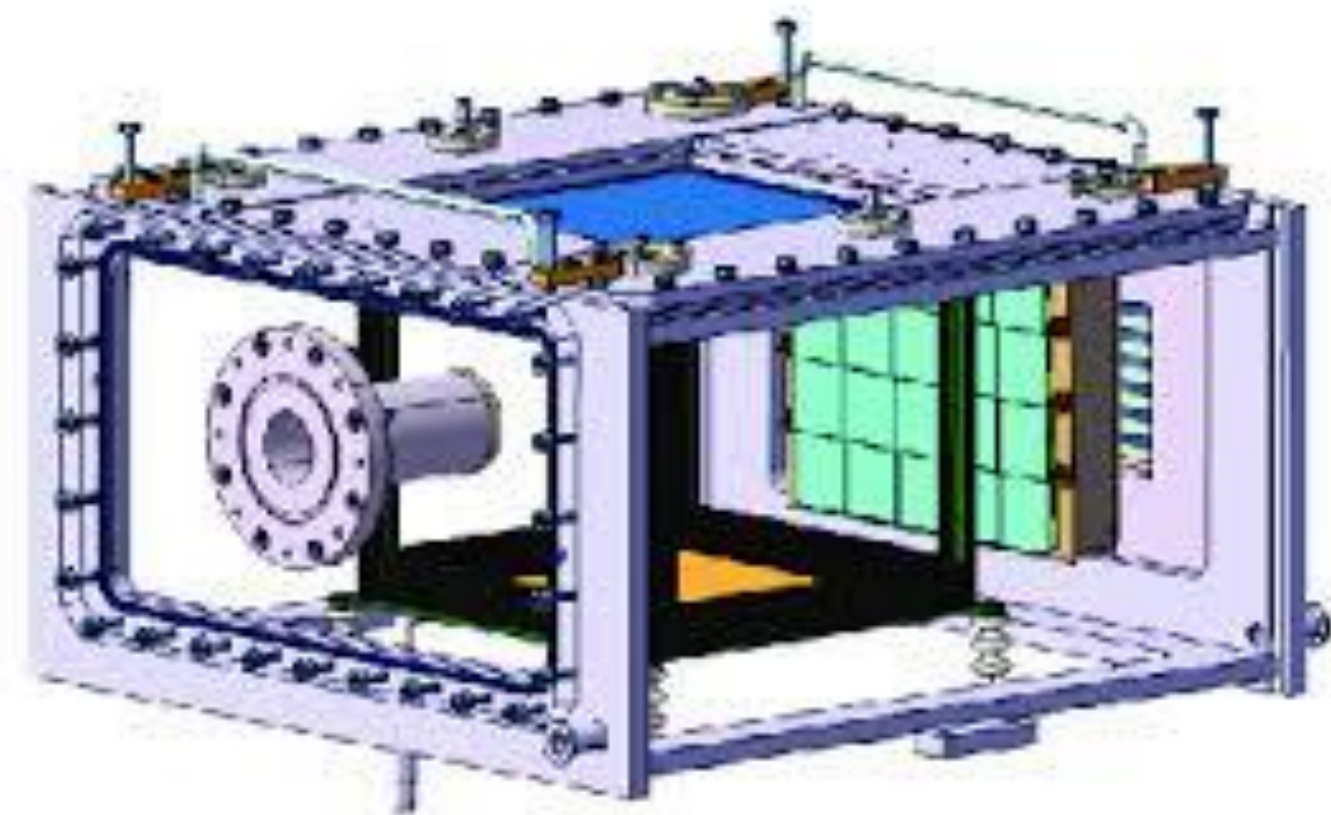

Success in performing direct reactions with beams < 1000 pps **at TRIUMF** within:

- 4 days measurement for transfer $^{11}\text{Li}(d,p)^{12}\text{Li} \rightarrow$ cross section \sim few mb
- 1 days measurement for resonant elastic scattering $^{20}\text{Mg}+p \rightarrow$ cross section \sim barn

Nuclear structure studies at the drip-lines with Active Targets → Complementary studies to TIGRESS+SHARC

Experimental methods → well suited for active targets

- Resonant elastic scattering → unique geometry + exp in 3-5 days
- Inelastic scattering using different probes (p,p'),(d,d'),(a,a') → internal trigger + exp in 2-3 days
- One/two-nucleon transfer/removal → increased target with good resolution + exp in 4-5 days
- Future : Charge exchange reactions ($^3\text{He,t}$) etc..

Physics cases → **High scientific impact**

- Resonance and near threshold spectroscopy, proton emission
- Open quantum systems: continuum and 3N-body forces
- Isospin mirror-symmetry
- Evolution of shell gaps
- Nuclear astrophysics

Beams with intensities

$I \sim 500 - 5 \times 10^4$ pps

Beam energies : 5 AMeV-15 AMeV

Light-Medium mass region

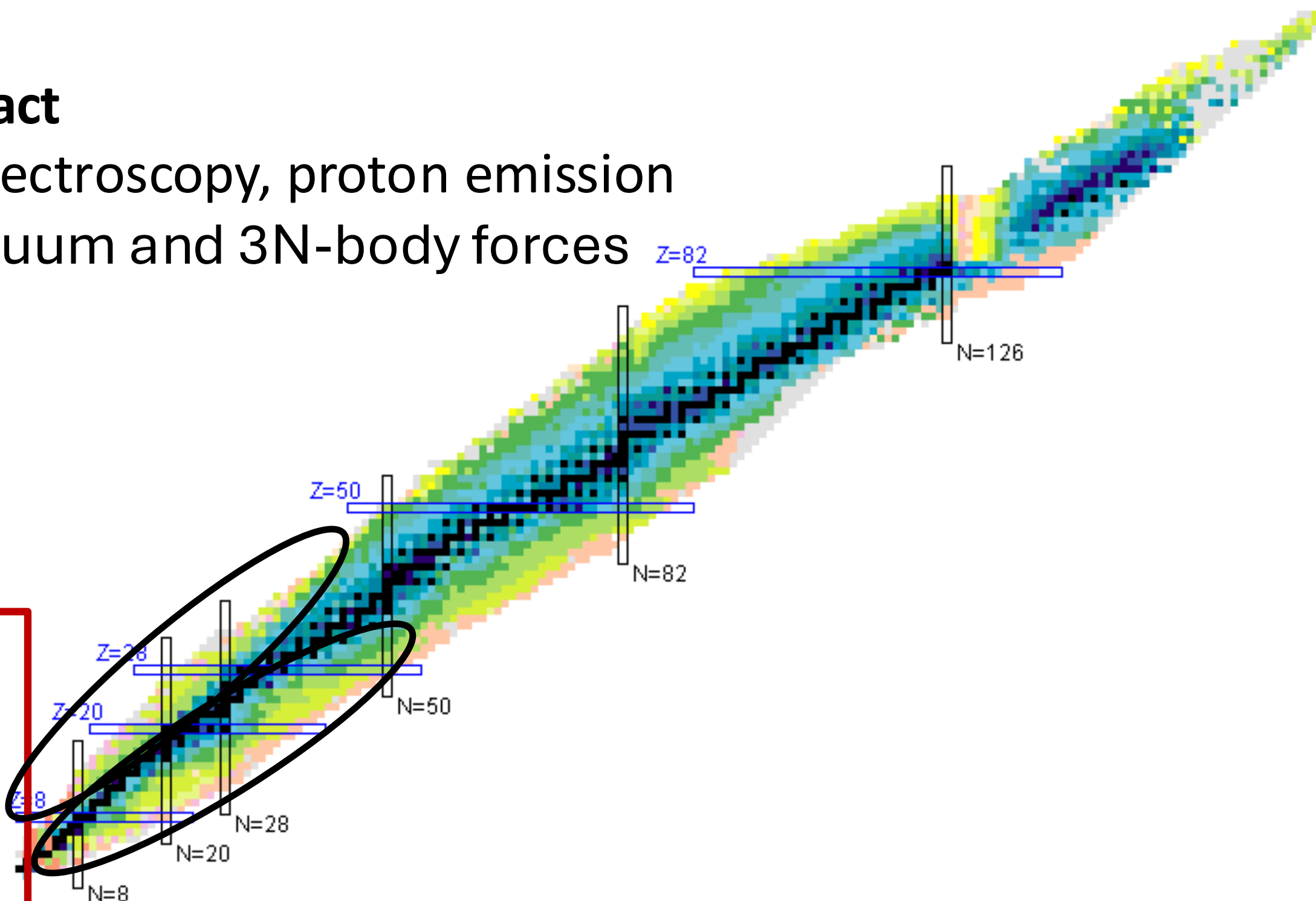

Multipurpose scattering chamber at TRIUMF

SEC @ HiE-ISOLDE

Reaction dynamic studies

- Dependence on:
 - Nuclear structure (halo, clustering ...)
 - Isospin
- Fission studies
- Clustering

Indirect methods for nuclear astrophysics

- THM
- ANC



GLORIA @ SEC HiE-ISOLDE

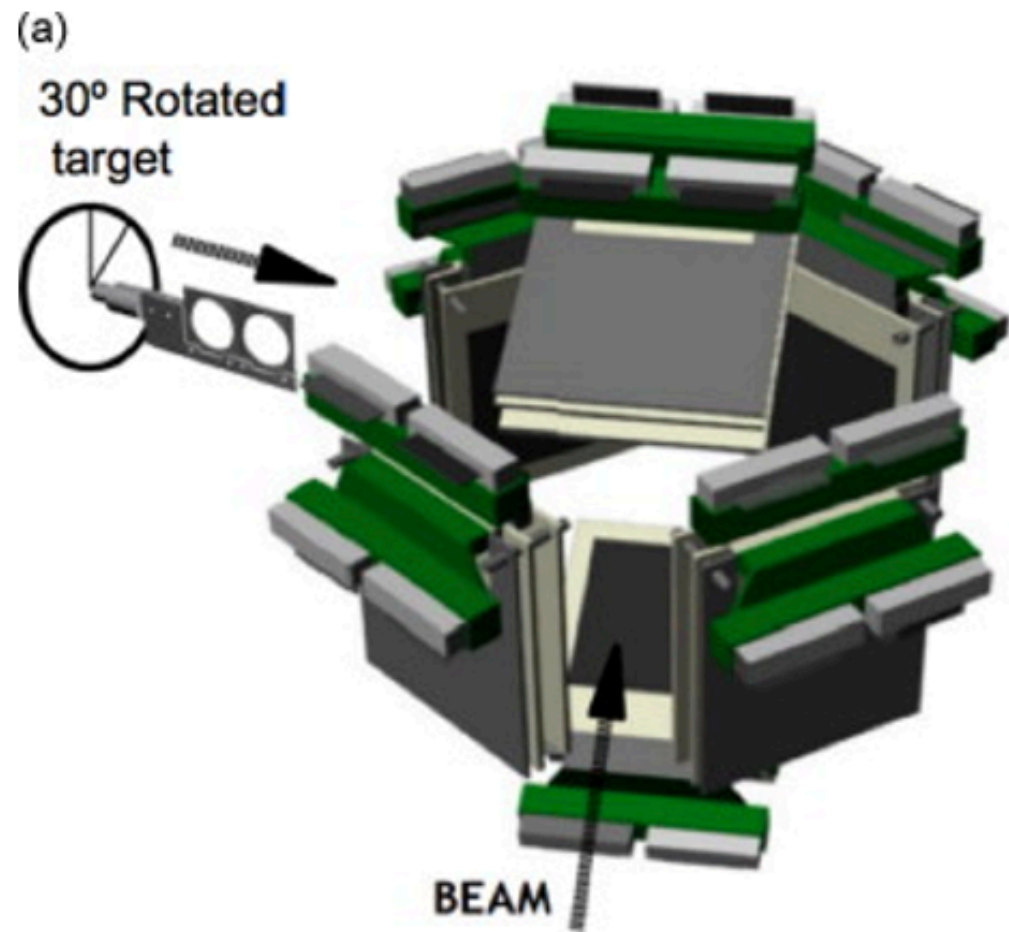

$\Delta E-E$ 20 $\mu\text{m}+500\mu\text{m}$

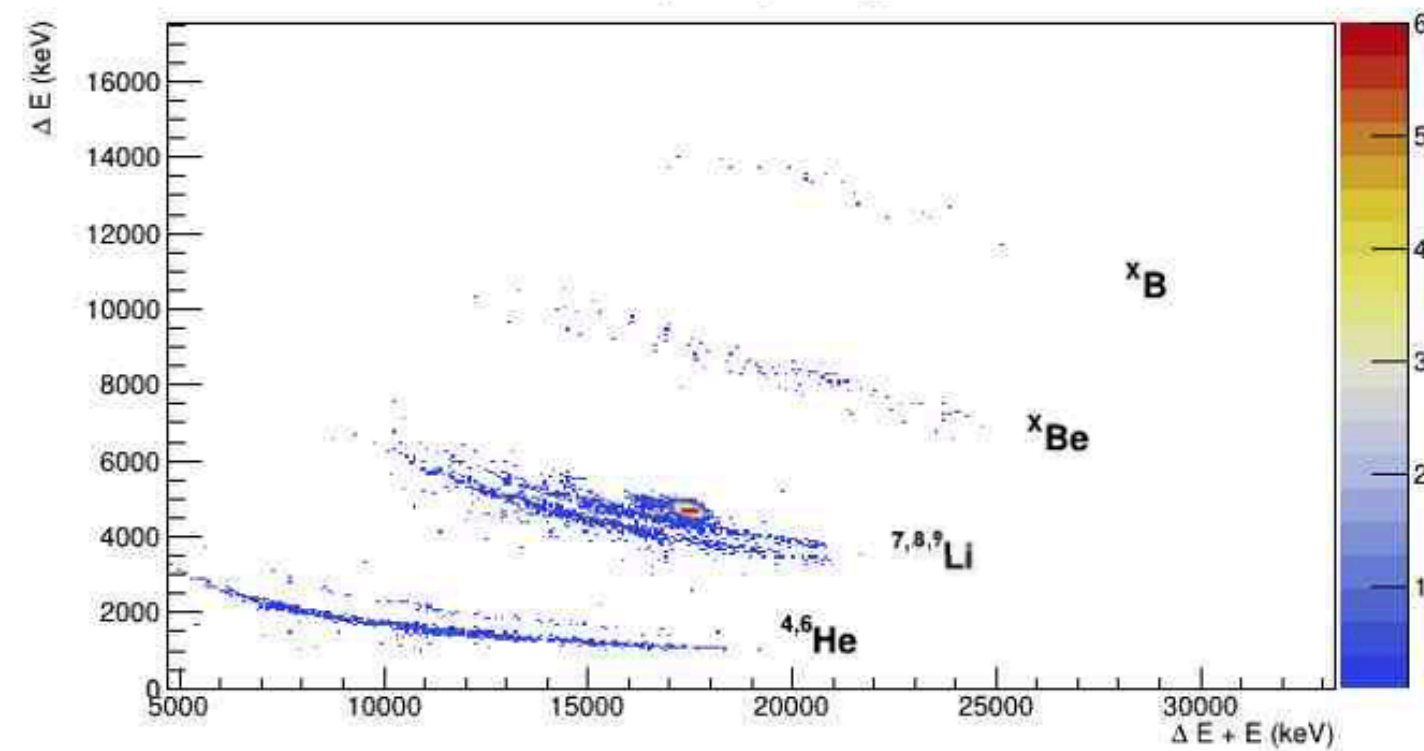

G. Marquínez-Durán et al.
NIM A 755 (2014) 69–77

$^8\text{B}+^{64}\text{Zn}$ @ HiE-Isolde

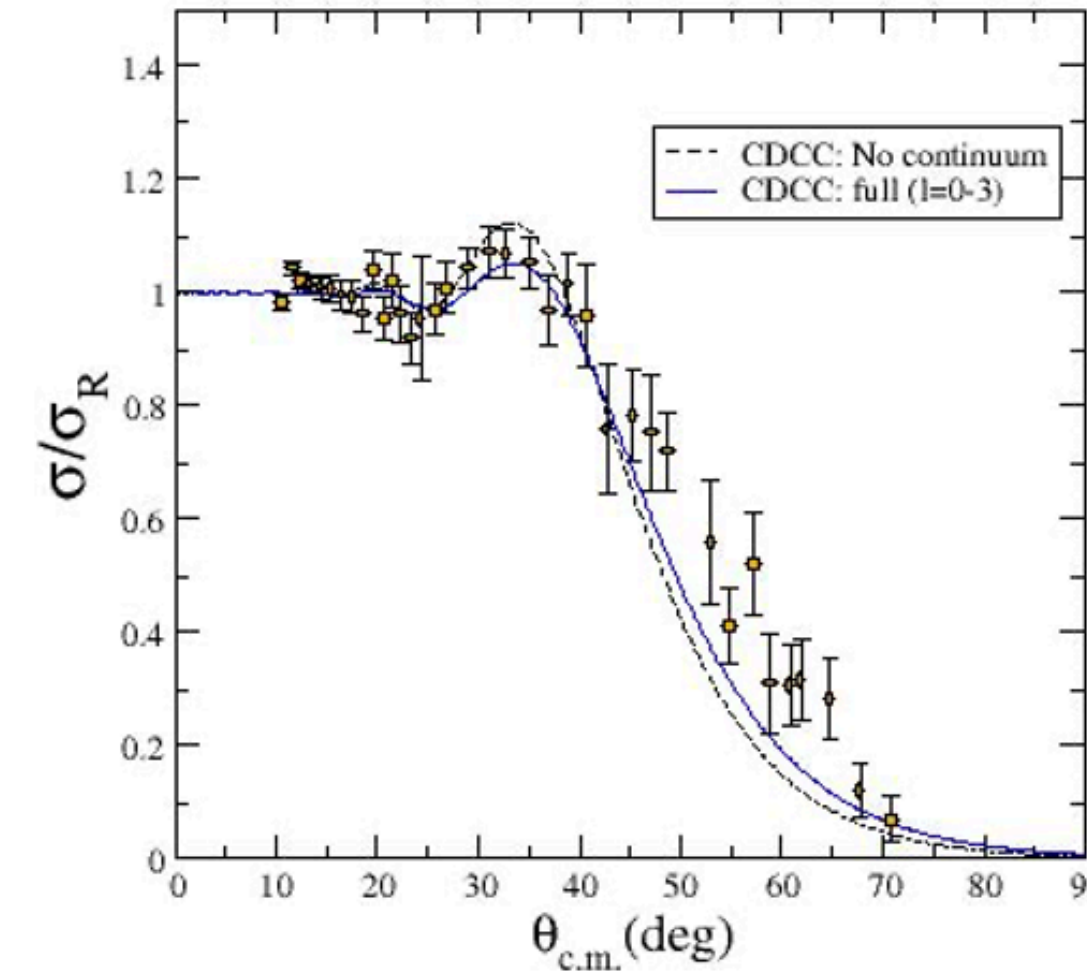

R. Spartà et al.
Phys Lett B 820 (2021) 136477

$^{11}\text{Li}+^{208}\text{Pb}$ @ TRIUMF

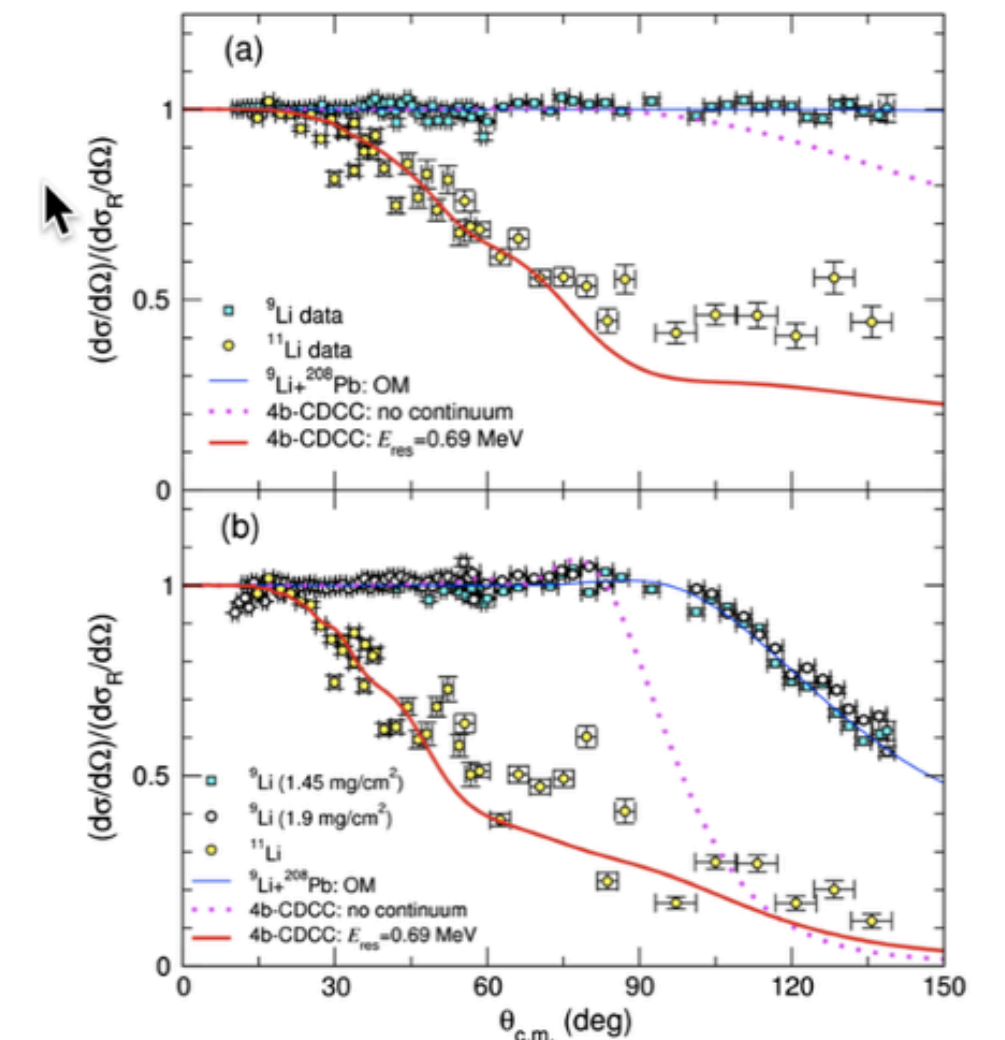

M.Cubero et al.
Phys.Rev.Lett. 109, 262701 (2012)

Wilton's slide

Four things:

- Big items..
- New things
- Be prepared for the time structure
- Count the beam: Zero degree detection TRIFFIC Advanced trifoil (transparent, zero dead time)

5 - actually there are five things. Scheduling!!
... do not switch off a running experiment

Solenoidal spectrometers (2010 ...)

Solenoidal spectrometers have proven to be a highly versatile approach to studying nuclear reactions for structure, astrophysics, and applications

■ HELIOS
■ SOLARIS
■ ISS
(Not a incomplete list, but close)

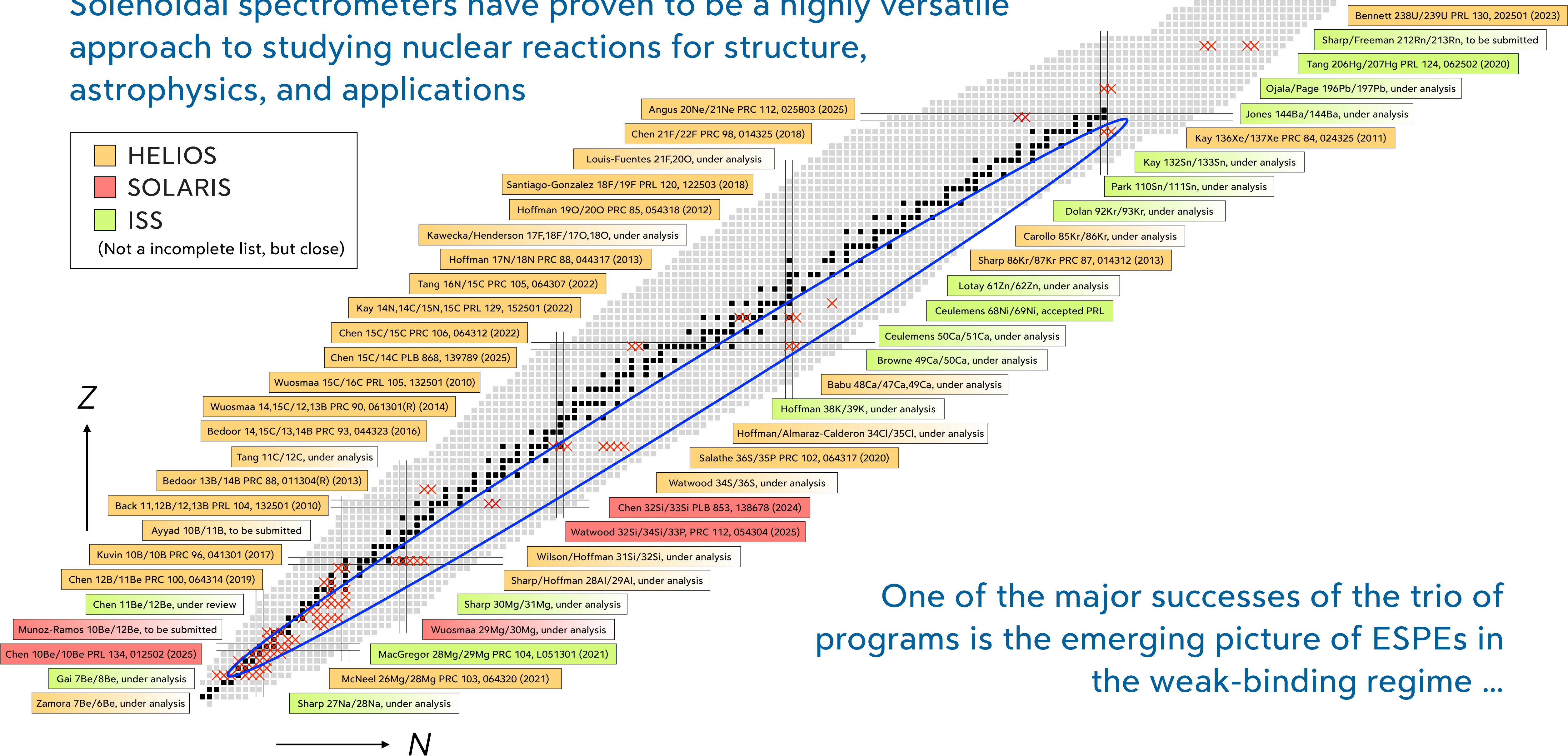

One of the major successes of the trio of programs is the emerging picture of ESPEs in the weak-binding regime ...

A productive trio

There is now a trio of these devices, in various stages of development: HELIOS @ ATLAS, ISS @ HIE-ISOLDE, and SOLARIS @ ReA6 (FRIB)

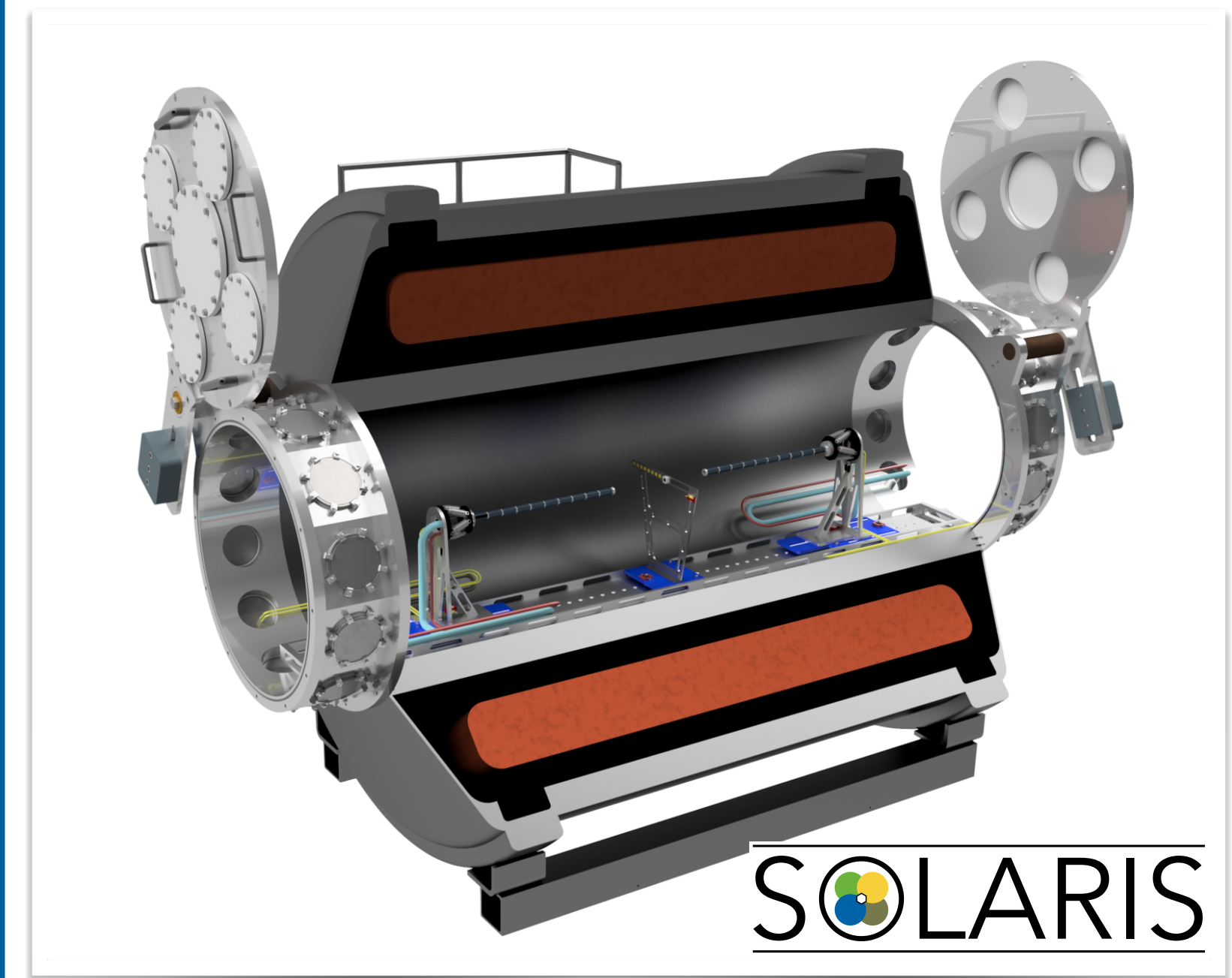
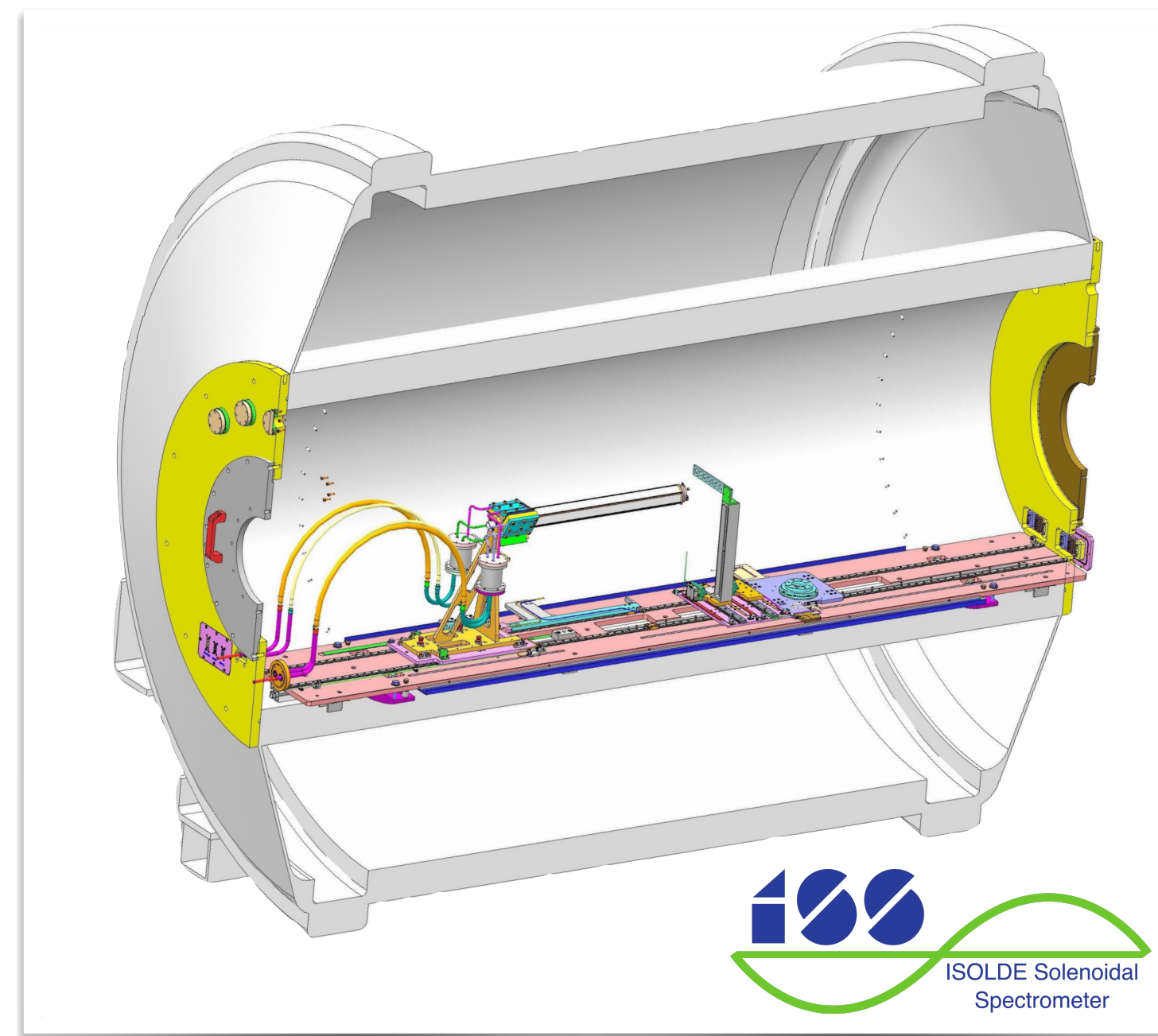
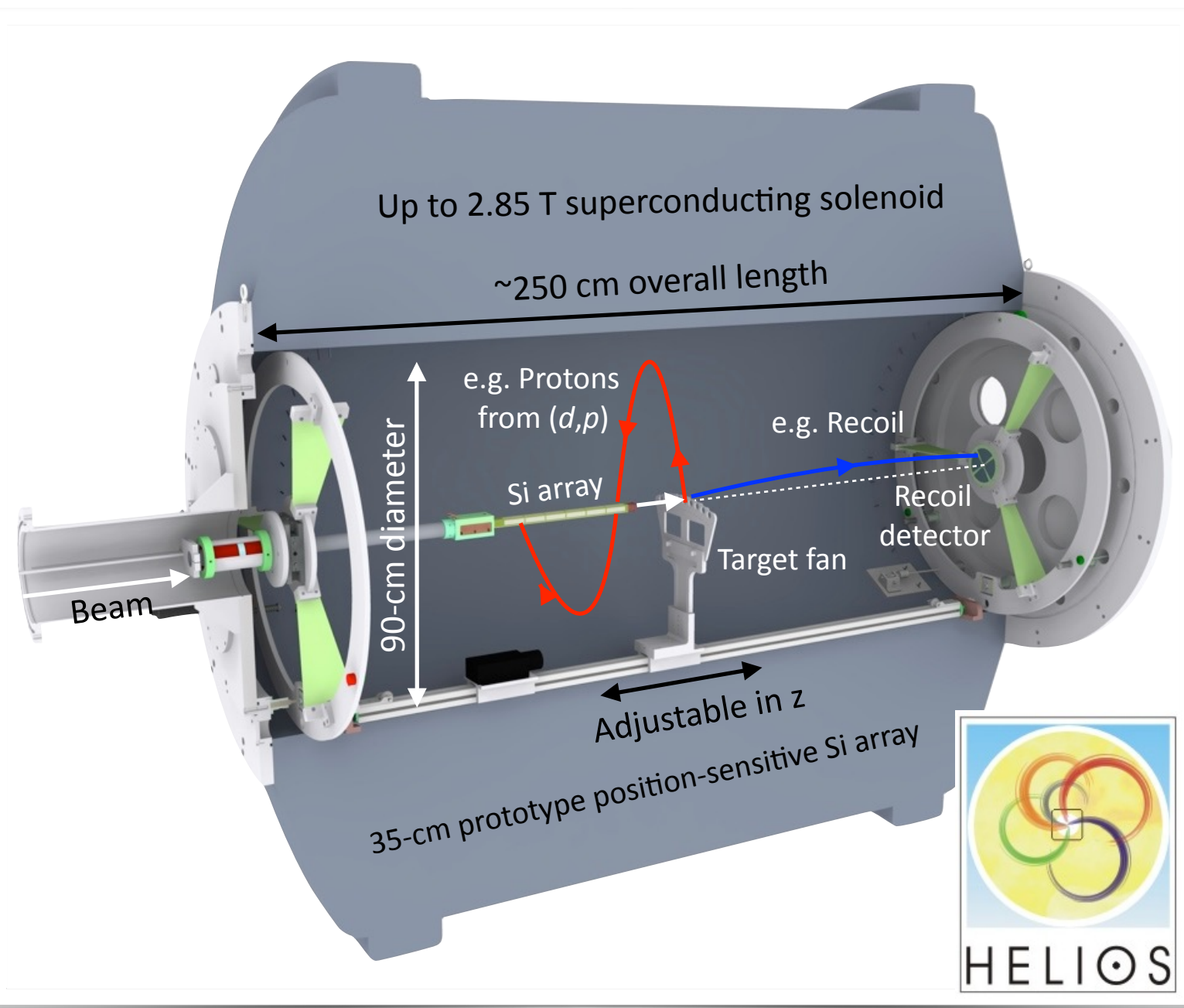

- **2008** onwards
- ATLAS beams (stable, RAISOR)
- Pioneered many solenoidal-spectrometer techniques
- Now dual mode

- **2018** onwards
- HIE-ISOLDE beams
- Dual mode (vacuum, SpecMAT)

- **2021** onwards
- ReA6 beam line
- Dual mode (vacuum, AT-TPC)
- Dual Si-array

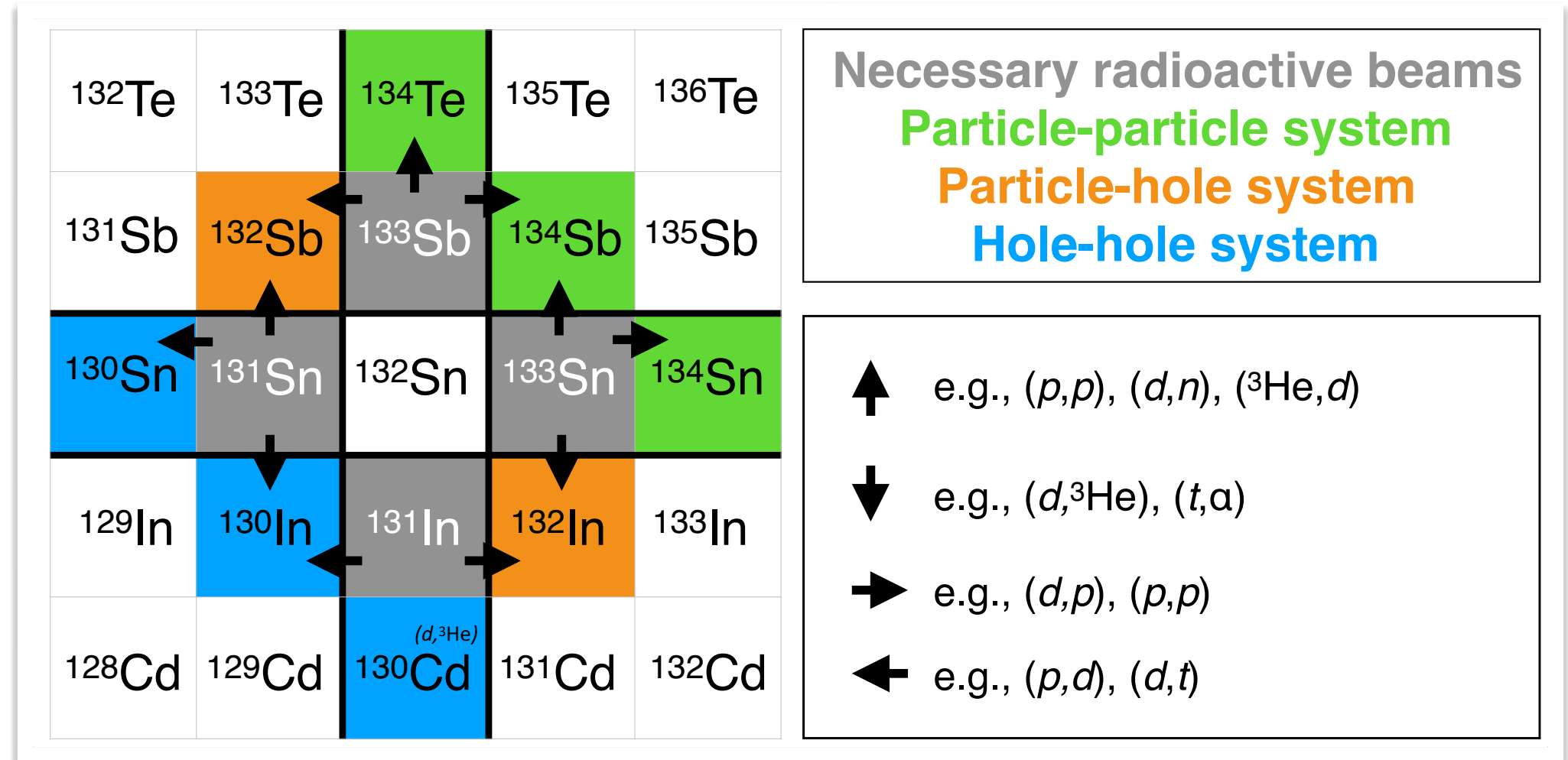
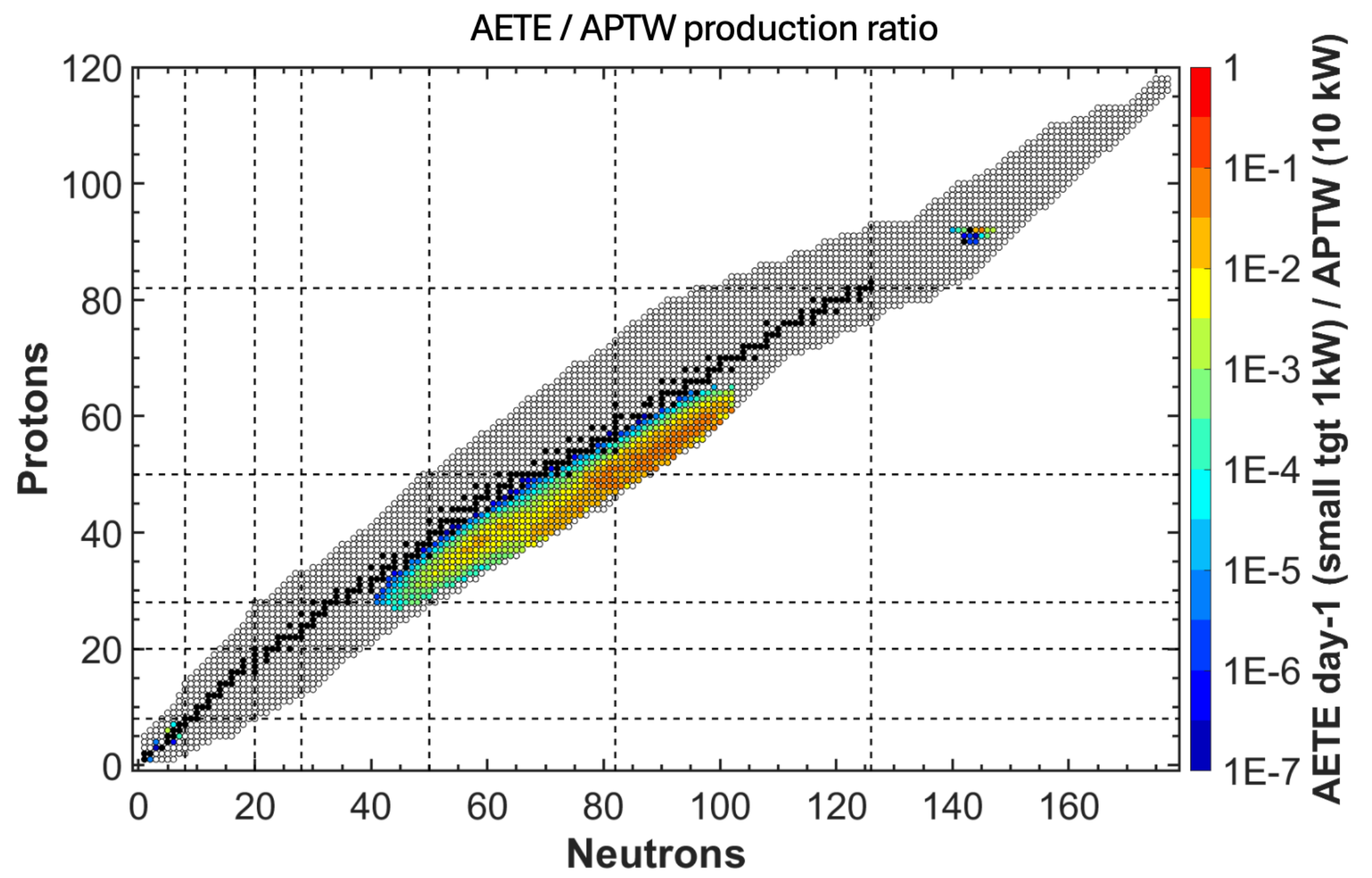
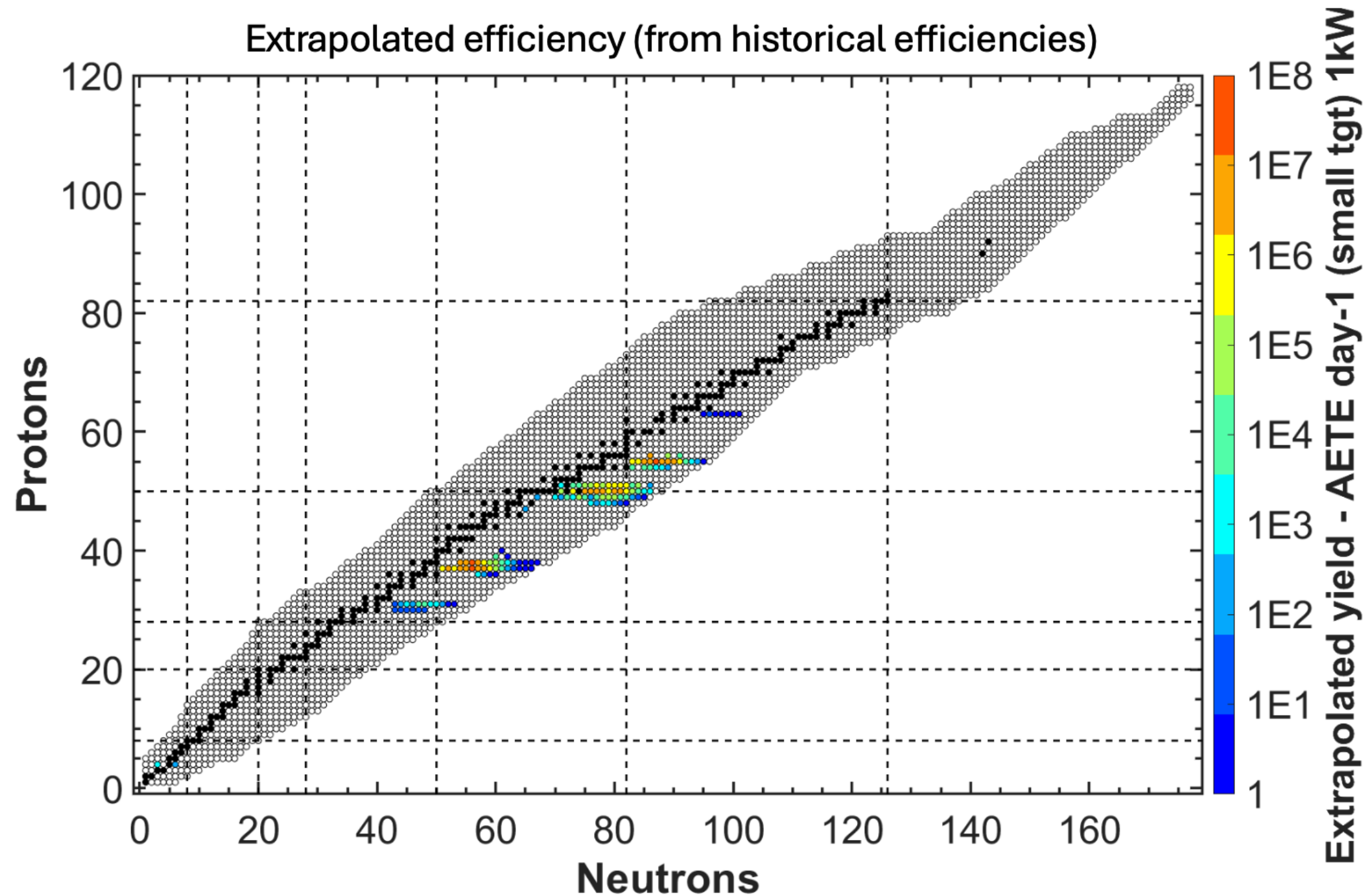

- 10 MeV/u
- >1e4 pps for silicon, >100 pps for active targets
- Forgiving with regard to beam structure (timing) and purity (some caveat with active targets)

And just because ...

PRL 115, 062701 (2015)

PHYSICAL REVIEW LETTERS

week ending
7 AUGUST 2015

Inverse Kinematic Study of the $^{26}\text{gAl}(d,p)^{27}\text{Al}$ Reaction and Implications for Destruction of ^{26}Al in Wolf-Rayet and Asymptotic Giant Branch Stars

V. Margerin,¹ G. Lotay,^{1,2,3,*} P. J. Woods,¹ M. Aliotta,¹ G. Christian,⁴ B. Davids,⁴ T. Davinson,¹ D. T. Doherty,^{1,†} J. Fallis,⁴

D. Howell,⁴ O. S. Kirsebom,^{4,‡} D. J. Mountford,¹ A. Rojas,⁴ C. Ruiz,⁴ and J. A. Tostevin²

¹School of Physics and Astronomy, University of Edinburgh, Edinburgh, EH9 3FD, United Kingdom

²Department of Physics, University of Surrey, Guildford GU2 7XH, United Kingdom

³National Physical Laboratory, Teddington, Middlesex TW11 0LW, United Kingdom

⁴TRIUMF, Vancouver, British Columbia V6T 2A3, Canada

(Received 27 March 2015; published 5 August 2015)

