

Presence and Future of the MRTOF systems at RIBF, and future projects in East Asia

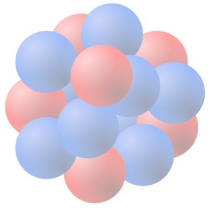

Marco Rosenbusch for RIKEN/SLOWRI and the WNSC-IPNS-KEK collaboration

RIKEN Nishina Center for Accelerator-based Science
2-1 Hirosawa, Wako, Saitama 351-0198, Japan

- MRTOF-MS at BigRIPS/SLOWRI and the Gas Cell
- Essential tools for MRTOF-MS at BigRIPS
- Mass Results 2020 – 2026
- Running Developments
- Mass uncertainty with rare events and contamination

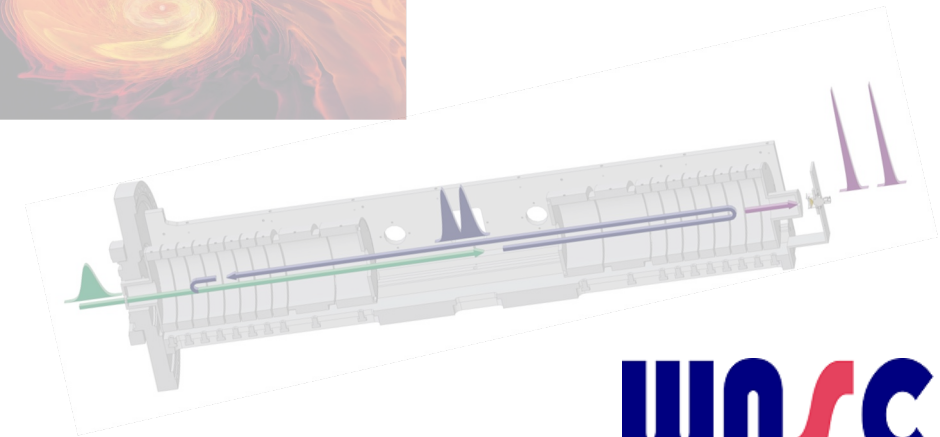
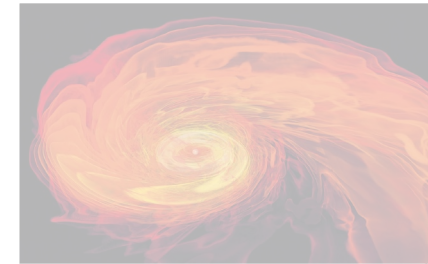
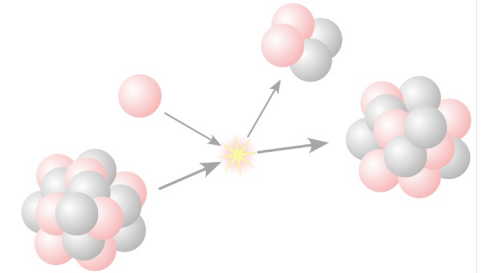

Current MRTOF facilities at RIBF

ガス充填型反跳核分離装置: GARIS-II (by GARIS team)

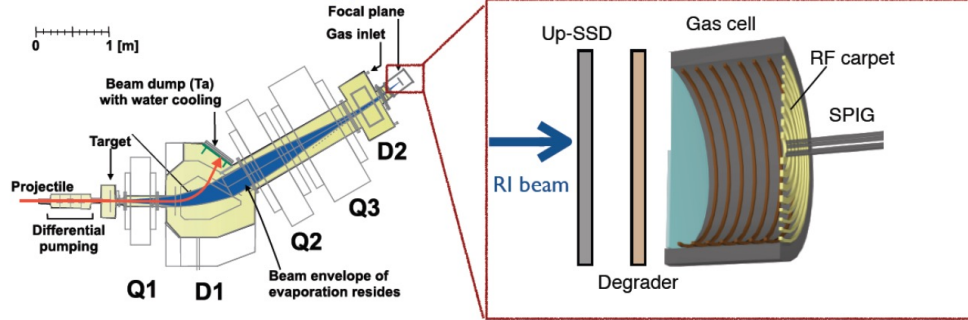

GARIS-III MRTOF coming soon



Original full-scale MRTOF primarily used for SHE studies

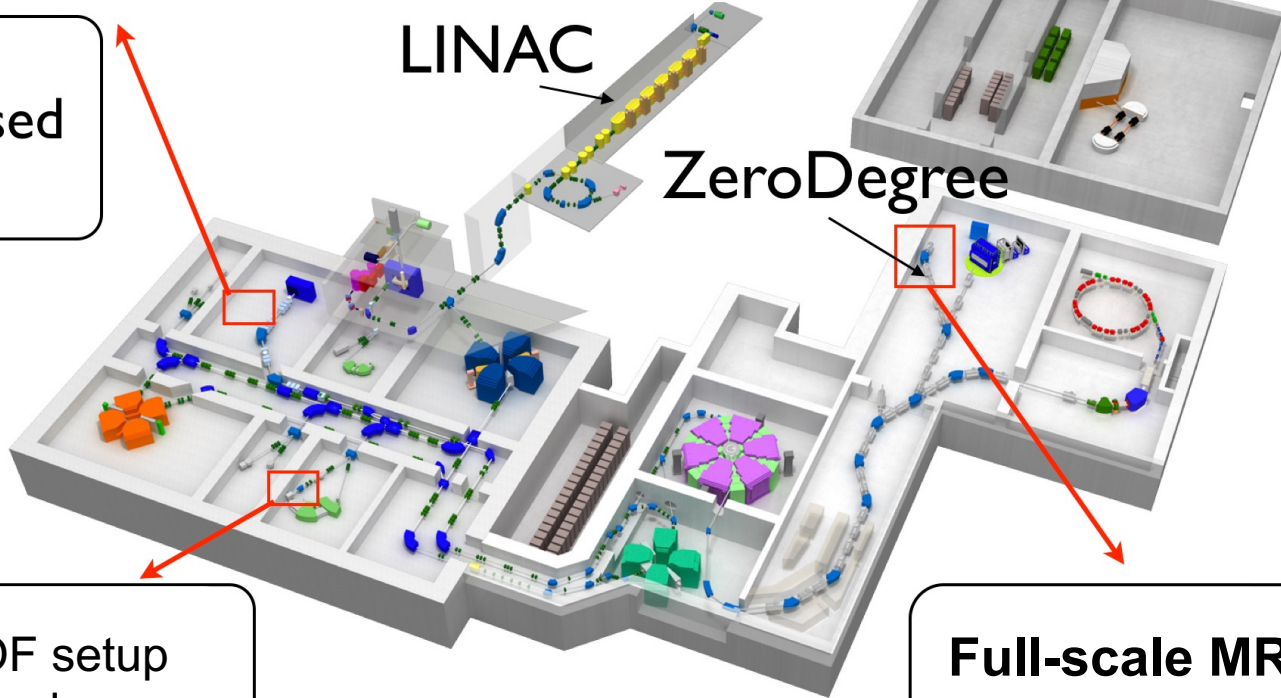

- Full scale = 1m
- Half-scale = 50cm

Half-scale MRTOF setup at KISS facility for laser spectroscopy and masses

Full-scale MRTOF setup In operation to accept BigRIPS beams

MRTOF-MS and the setup at BigRIPS/SLOWRI

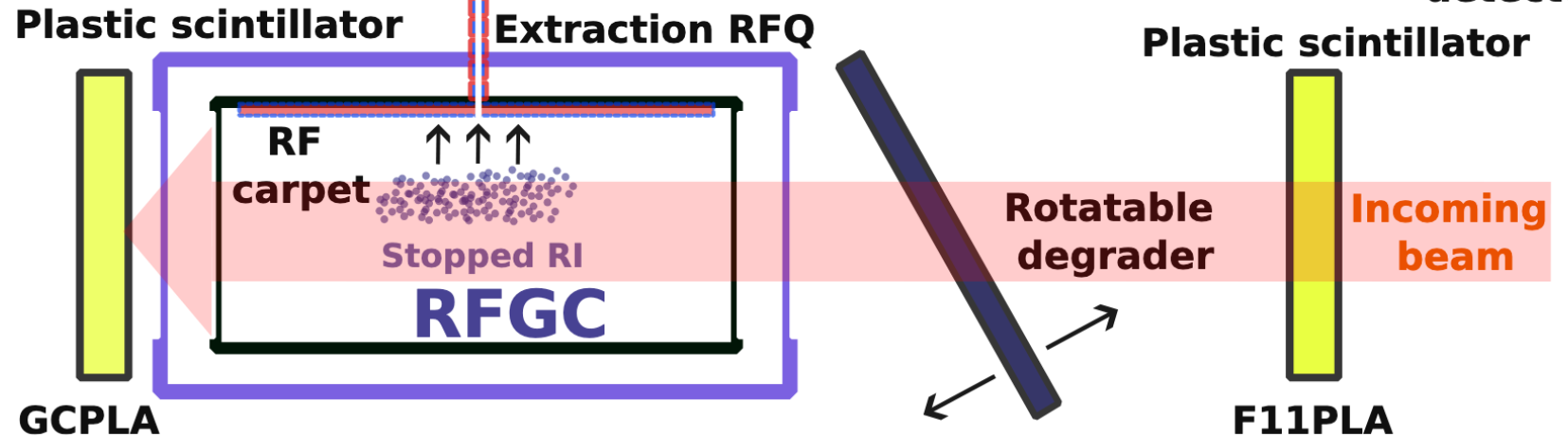
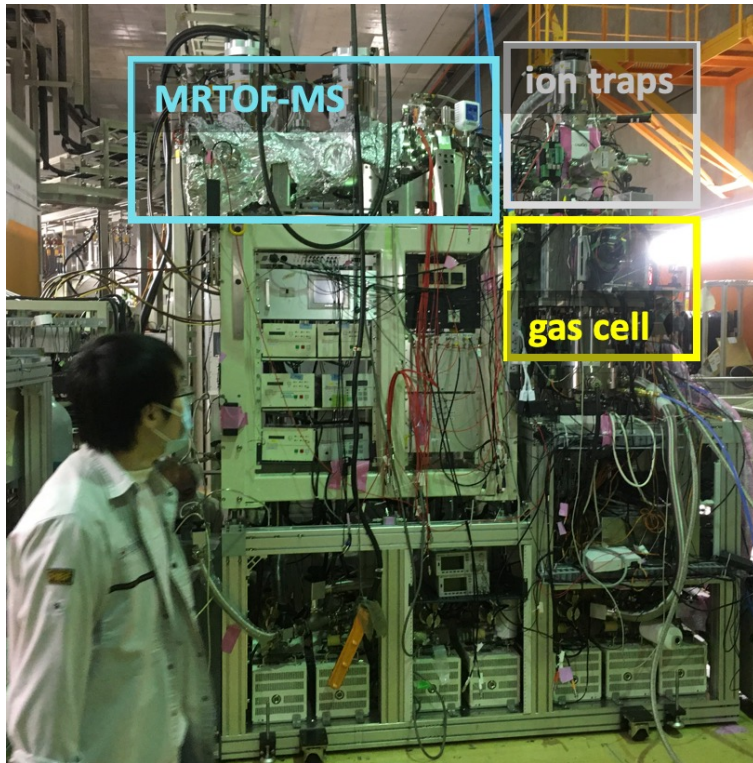
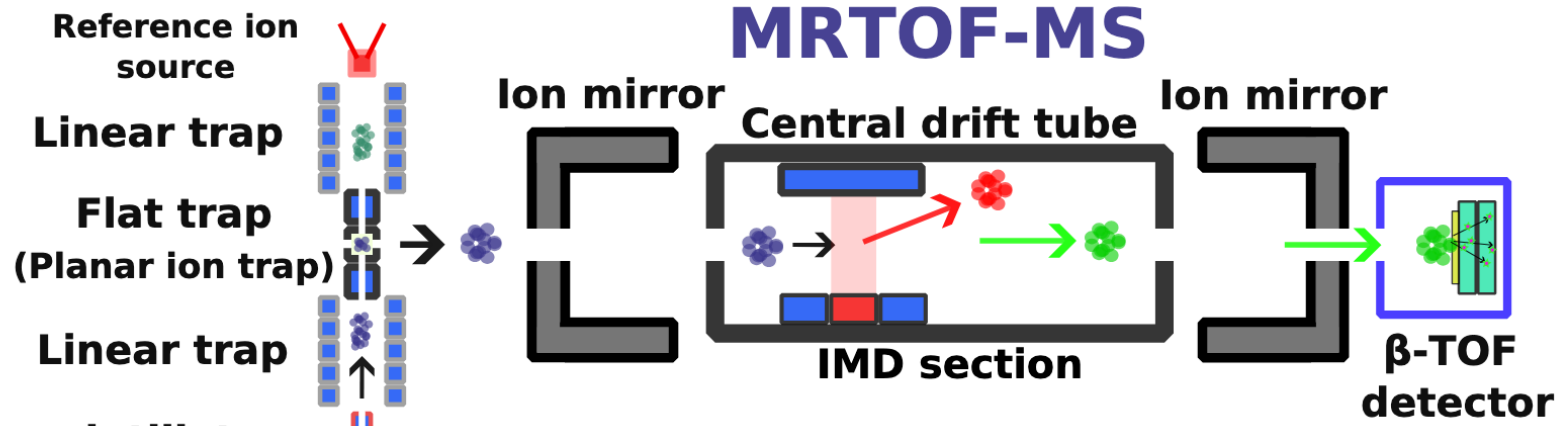
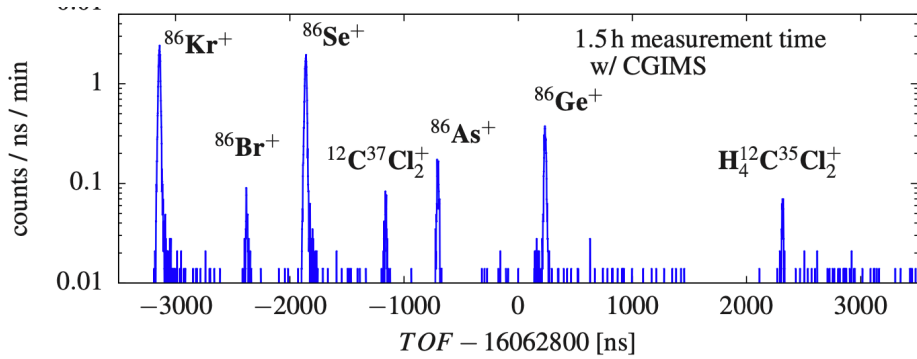

- Flight path of a few kilometers possible
- Short measurement time ≈ 10 - 20 ms
- Mass resolving power $R_m > 100,000$
- Relative mass precision $\delta m/m < 10^{-7}$

MRTOF-MS and the setup at BigRIPS/SLOWRI

New He gas-filled ion catcher (or also “radiofrequency gas cell” RFGC)

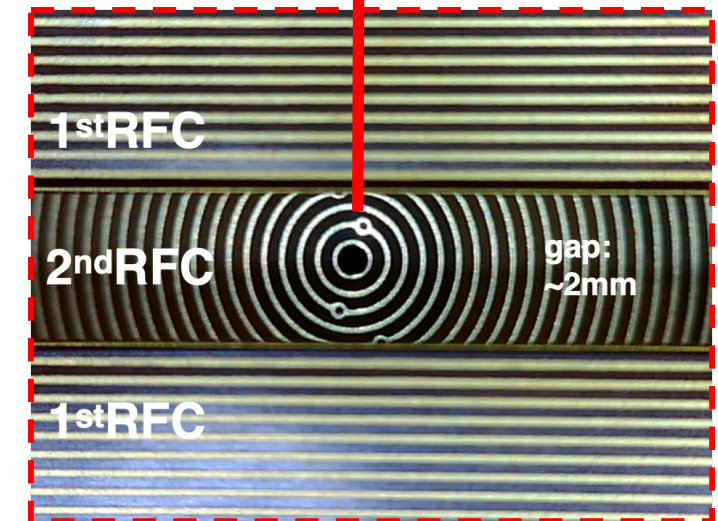
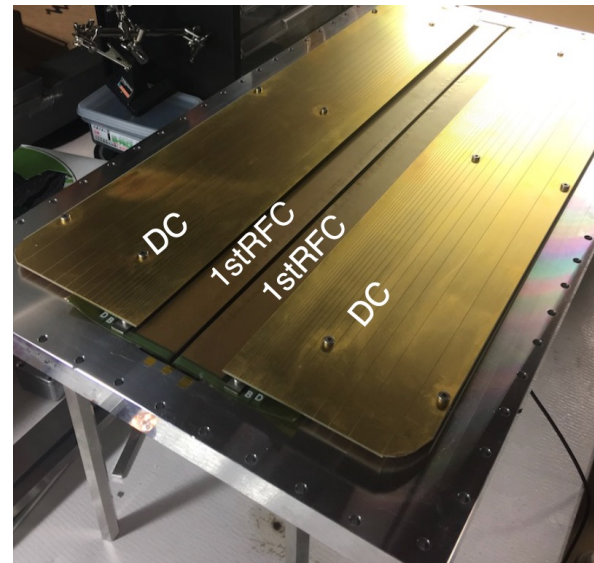
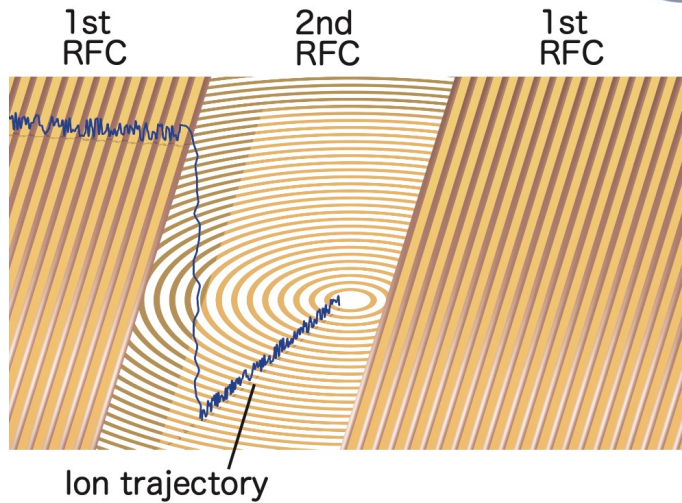
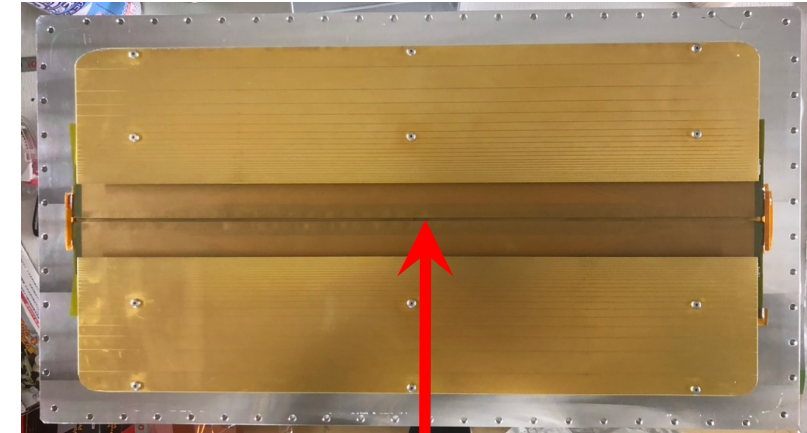
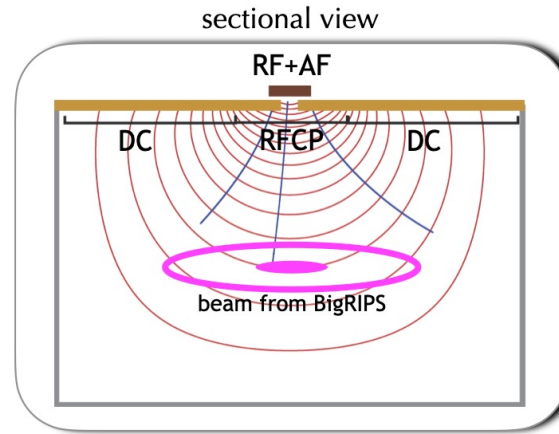
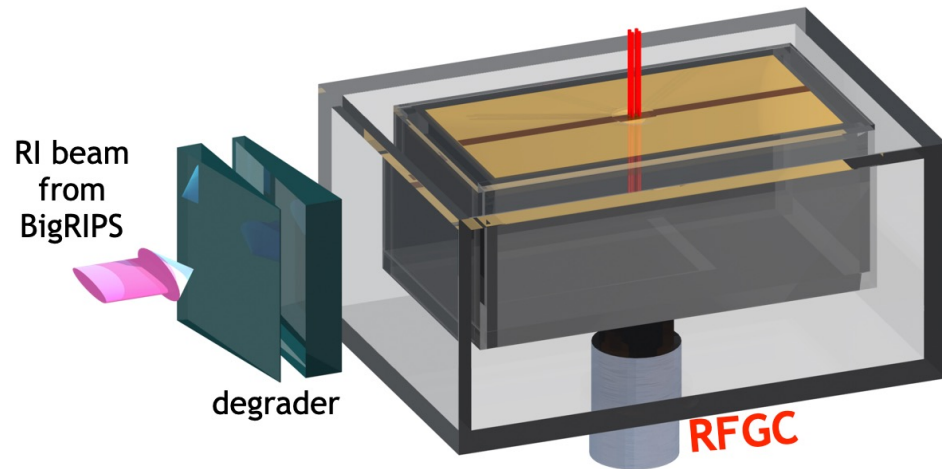

Through-beam gas cell

Through-beam gas cell with perpendicular extraction

- High-energy particles don't hit carpet area
- Transmission can be measured from upstream/downstream plastic
- Ions have wide axial distribution → space-charge reduction

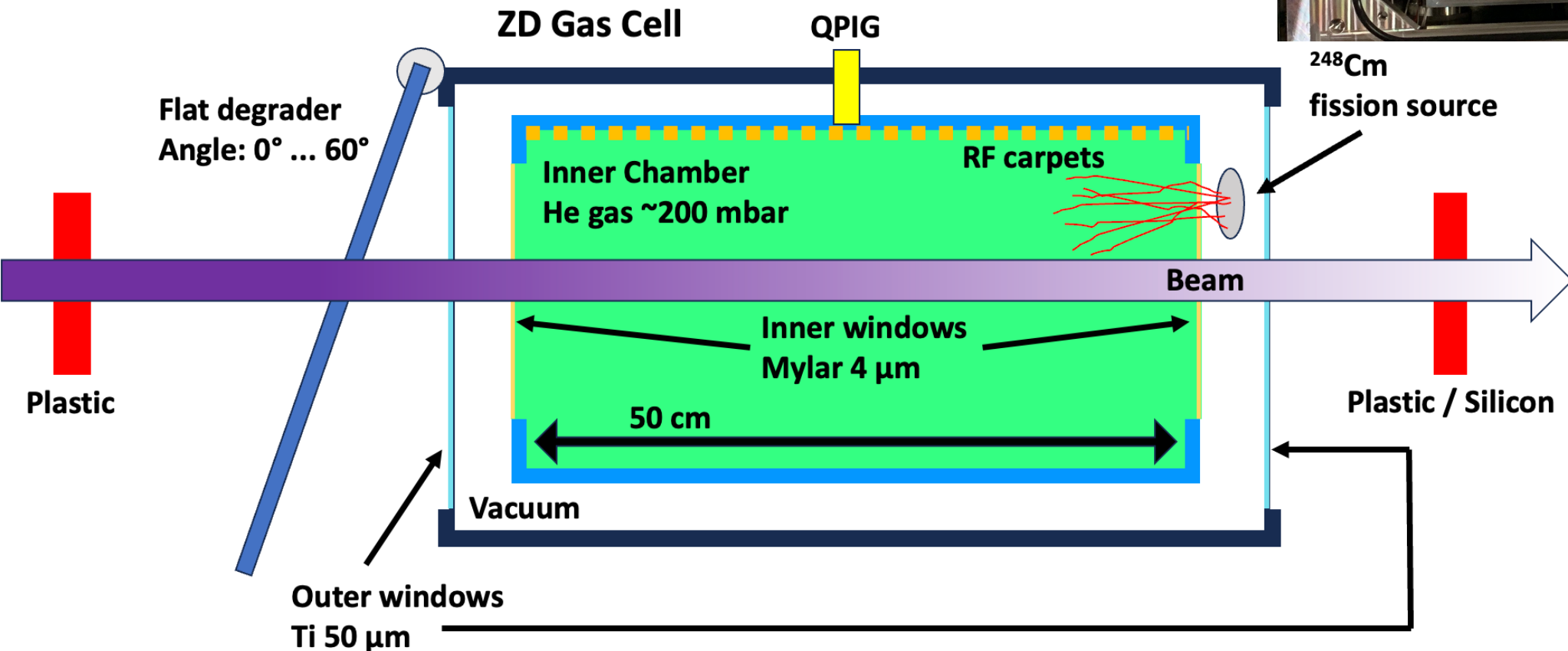
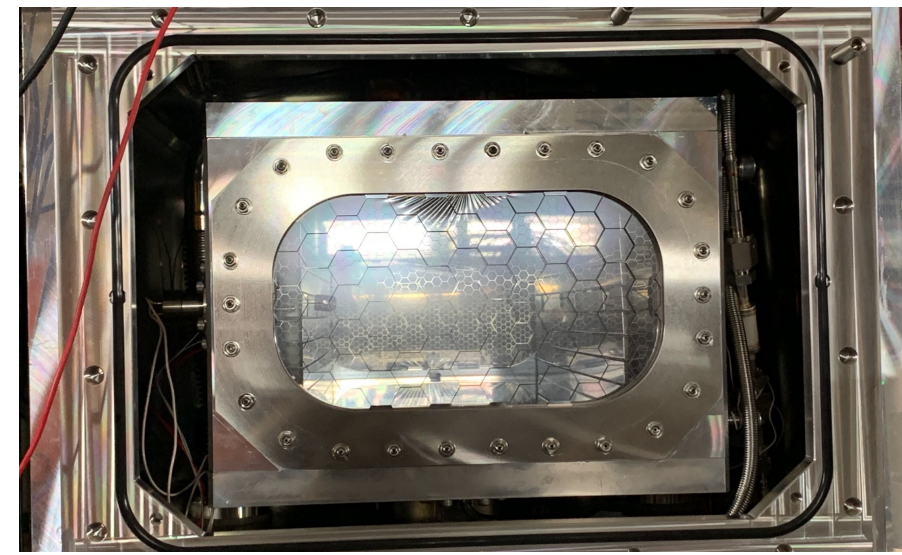

Essential tools: Through-beam opt.

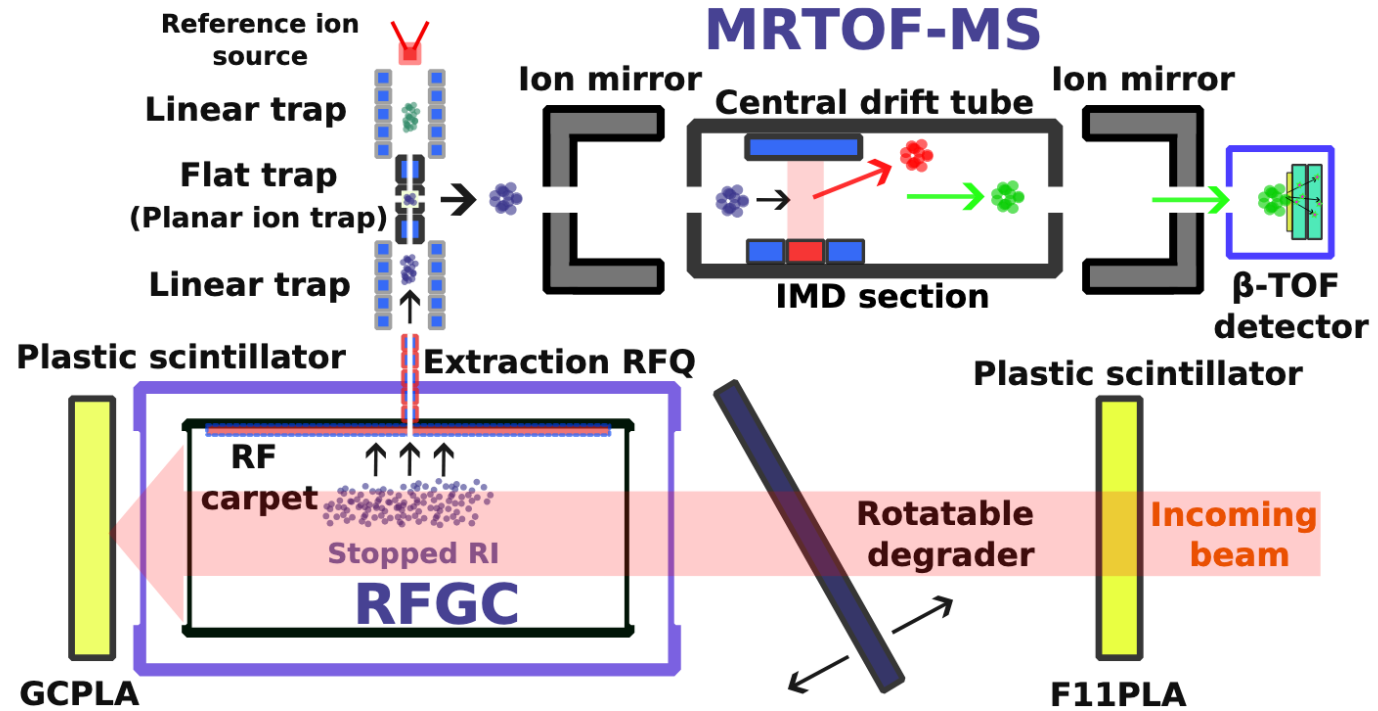
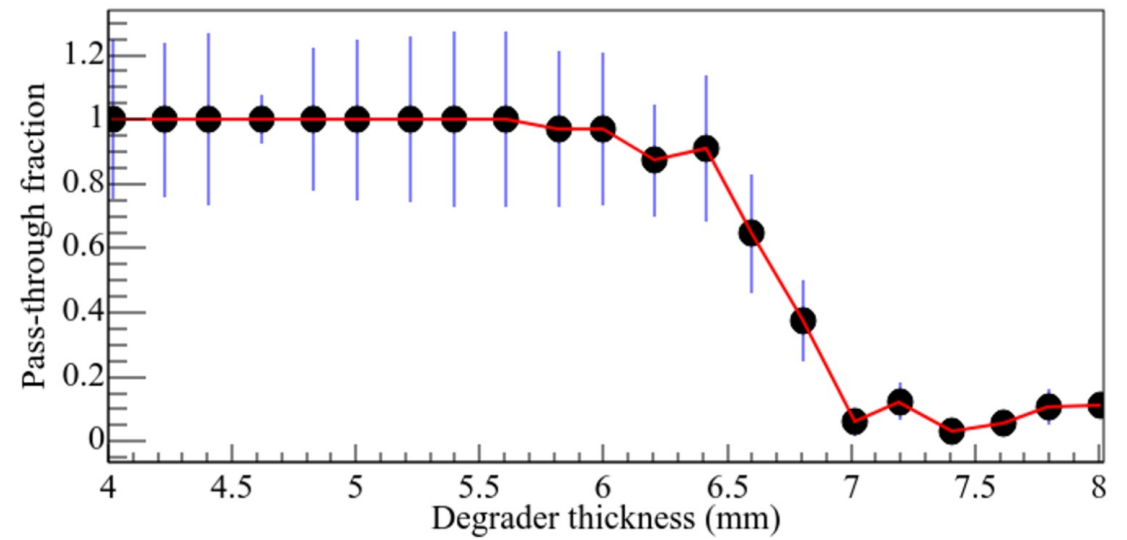
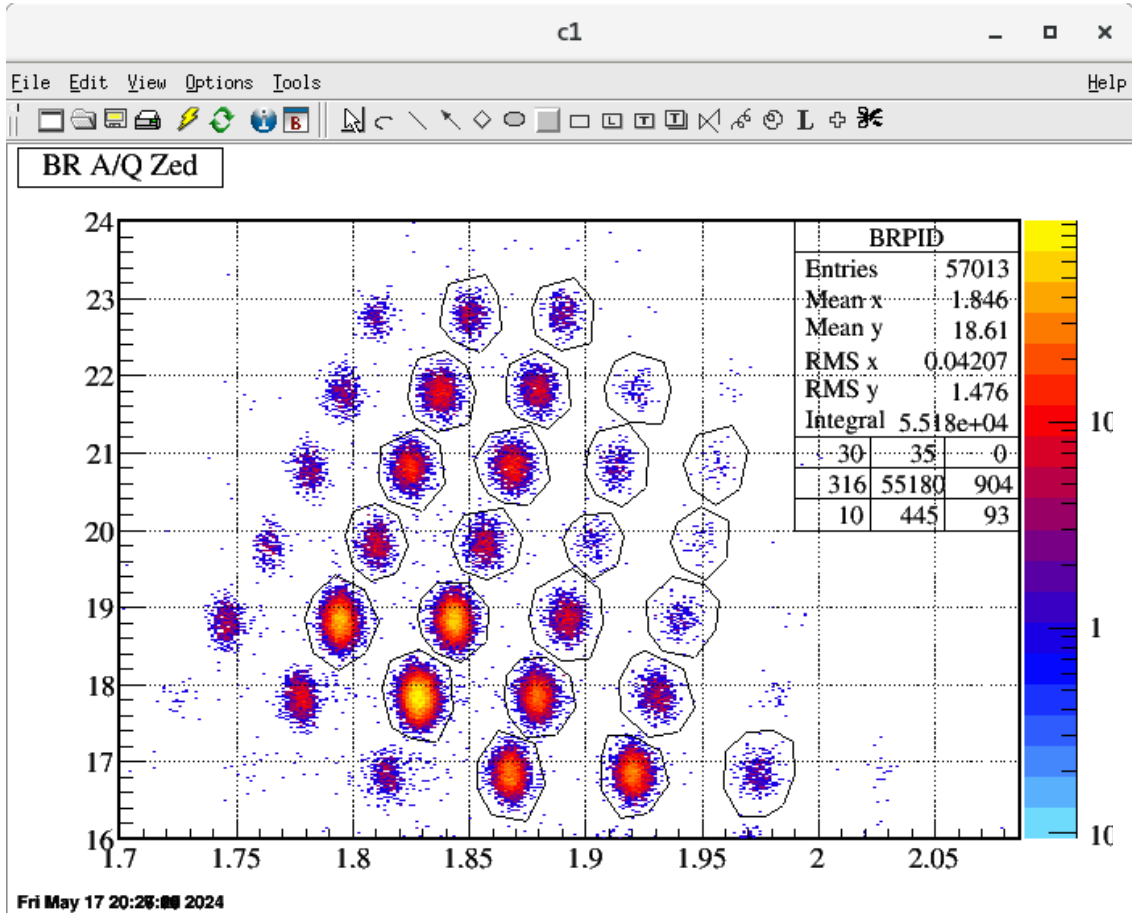

Essential tools: In-MRTOF deflector

- Selective kick-out possible
- **Selective protection of several masses now possible**
- Proper design: Kick out of unwanted ions with weak (30 V) pulse

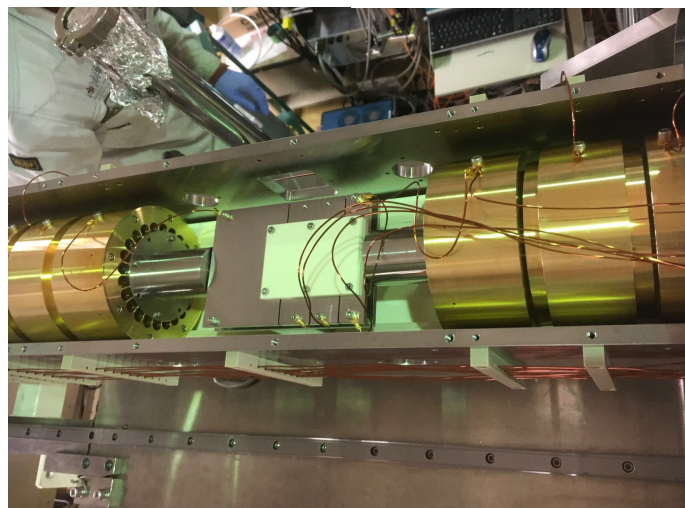
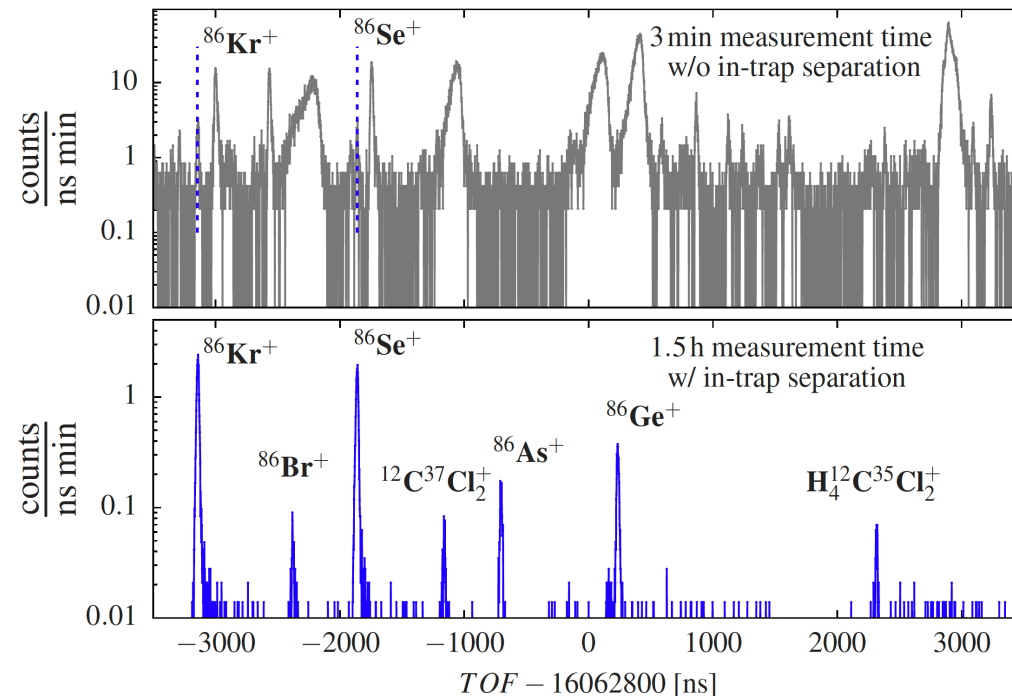
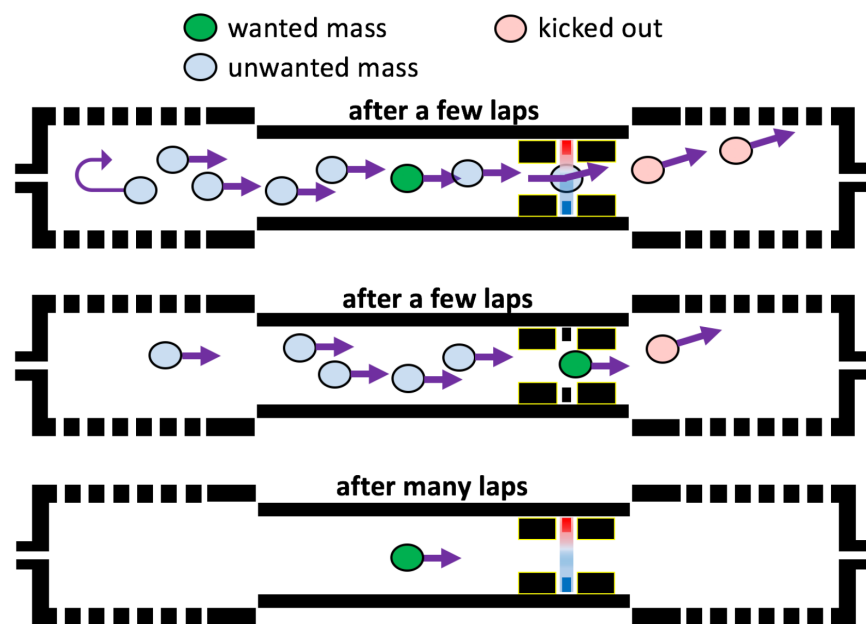

First MRTOF in-trap cleaning with deflector:
Y. Toker et al., J. Instrum. 4, P09001 (2009).

Development of deflectors:
T. Dickel et al., Nucl. Instrum. Meth. 777, 172 (2015).
P. Fischer et al., Rev. Sci. Instrum. 89, 015114 (2018).

Usage of mirror endcaps:
J. T. Johnson et al., Anal. Chem. 91, 8789 (2019).

- Selecting various isobar groups at the same time
- Calculating crossing time for all selected isotopes
- Defining “safety region” (distance from IMD), including asymmetry of motion (Down-Up / Up-Down)
- Generating pulse-train sequence
- Writing memory of sequencer → syncing to new sequence

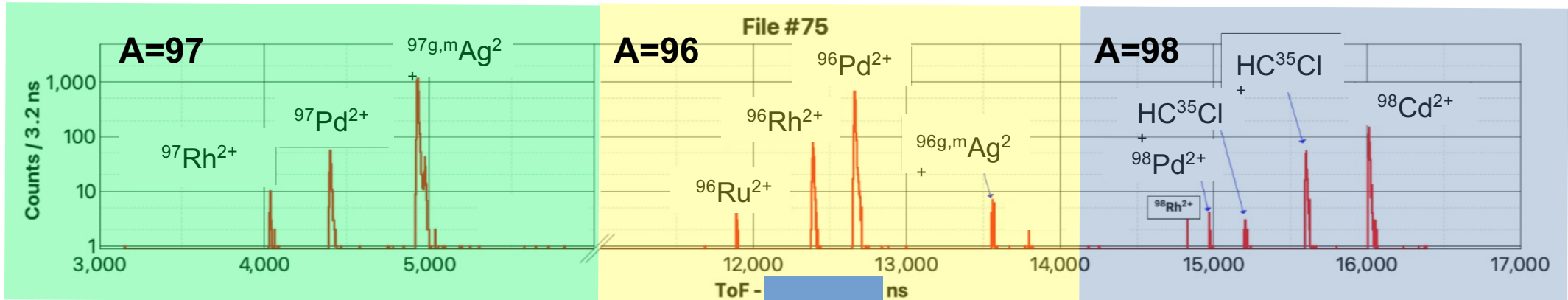
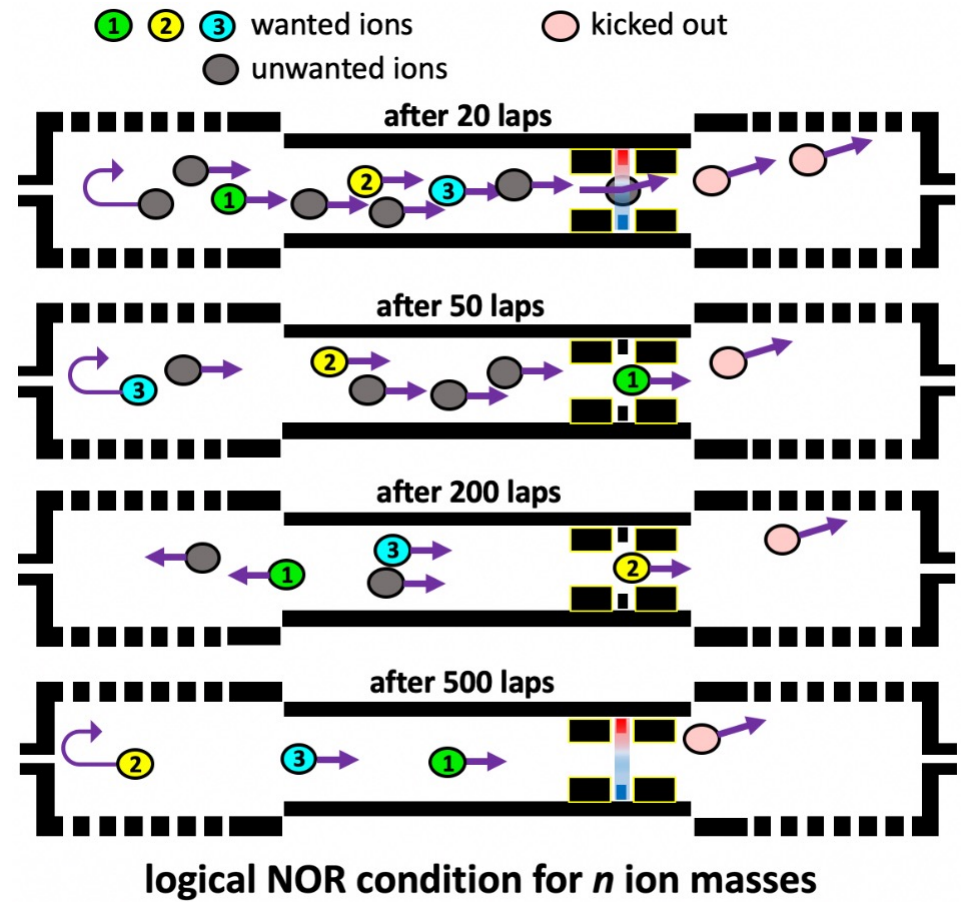
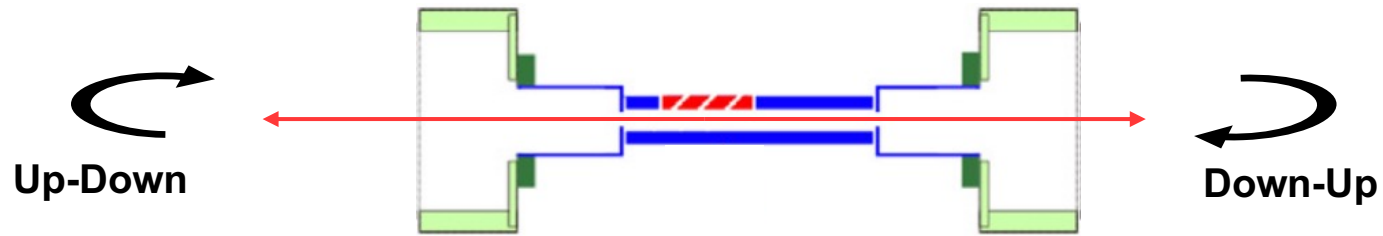

Choices for the pulse pattern

W. Xian et al. Front. Phys. 13:1644477

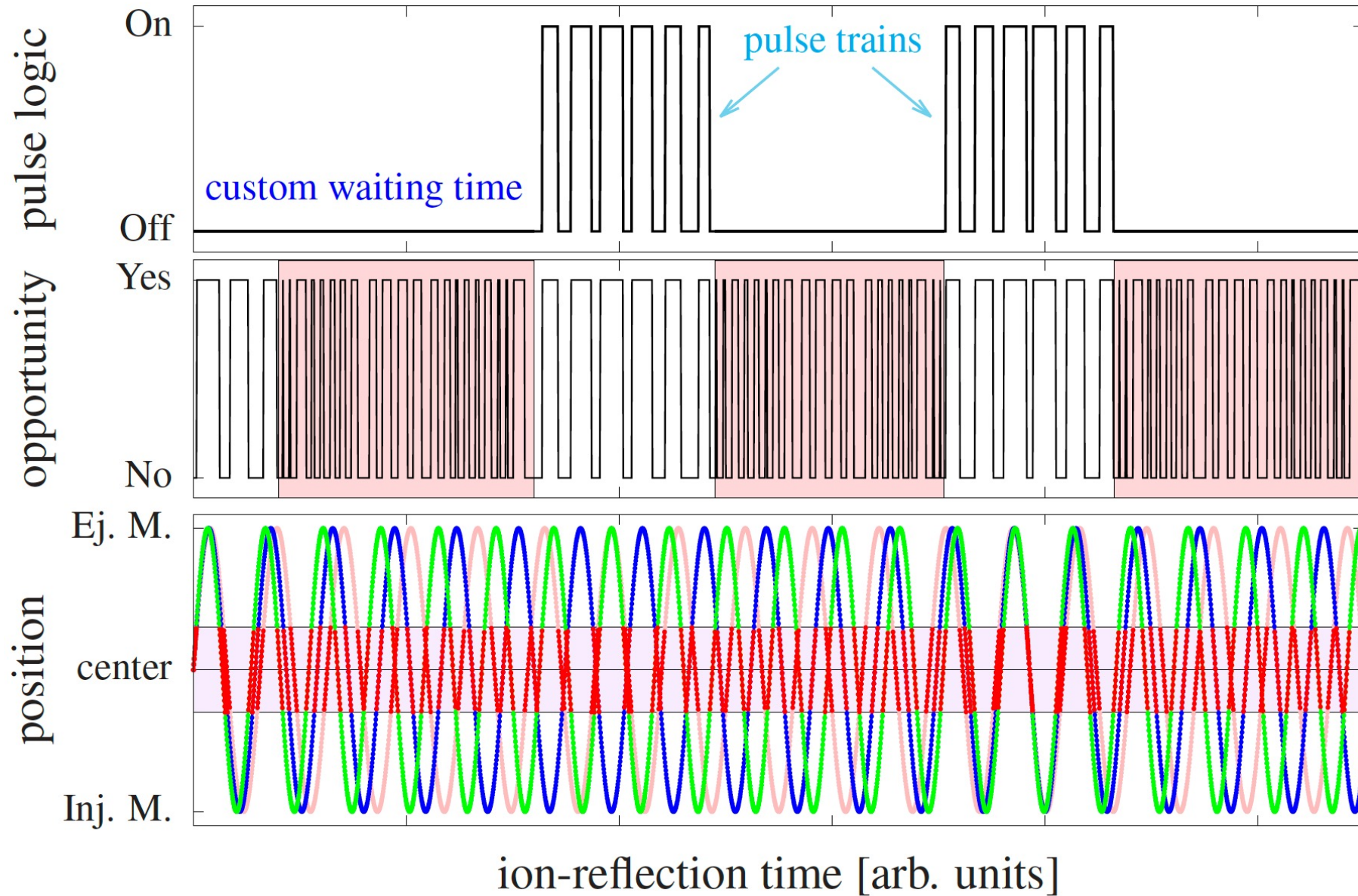

Decay correlated mass spectroscopy

T. Niwase *et al.*, PTEP 2023:031H01 (2023)

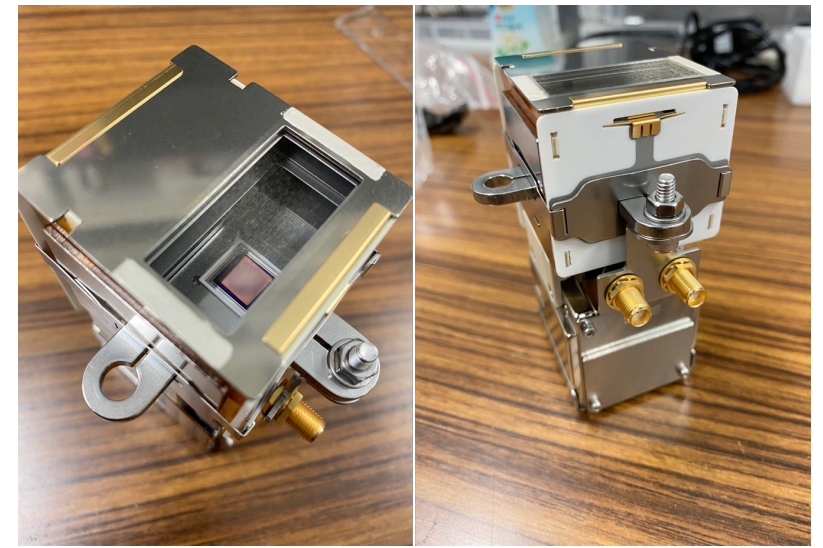
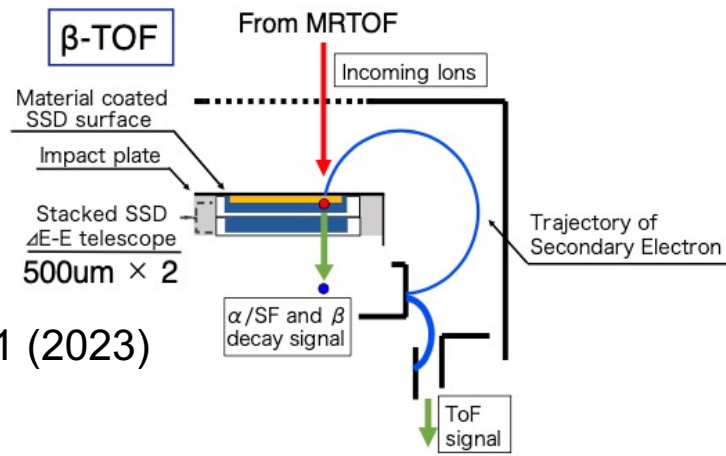

Correlation with TOF and β -signal
(The β -signal is the one passing through the double layered Si.)

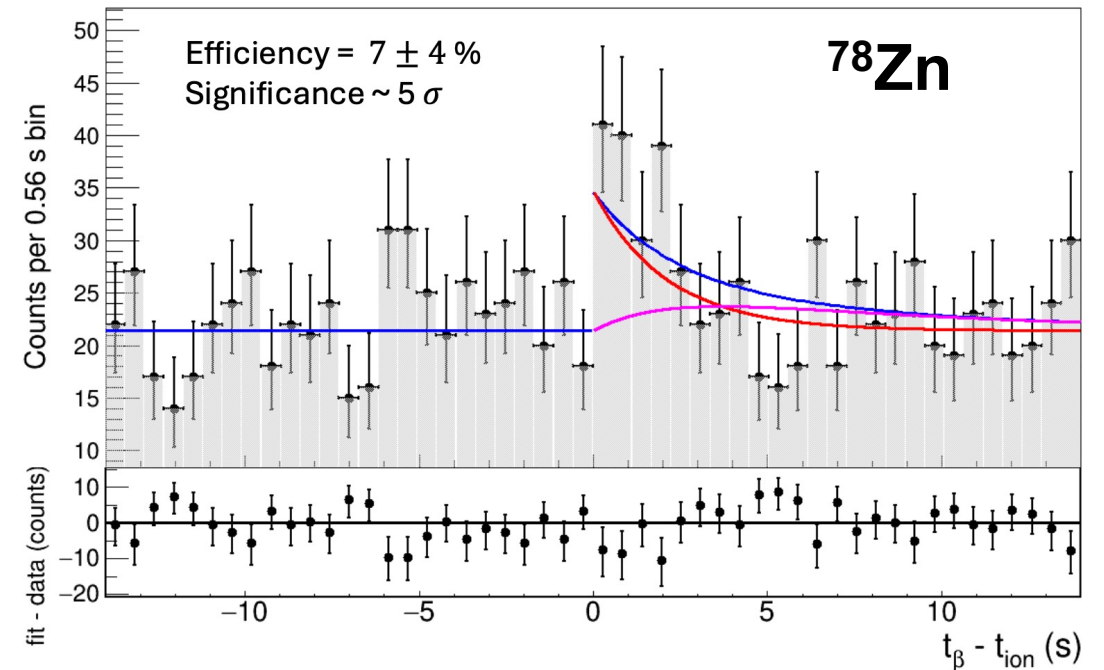
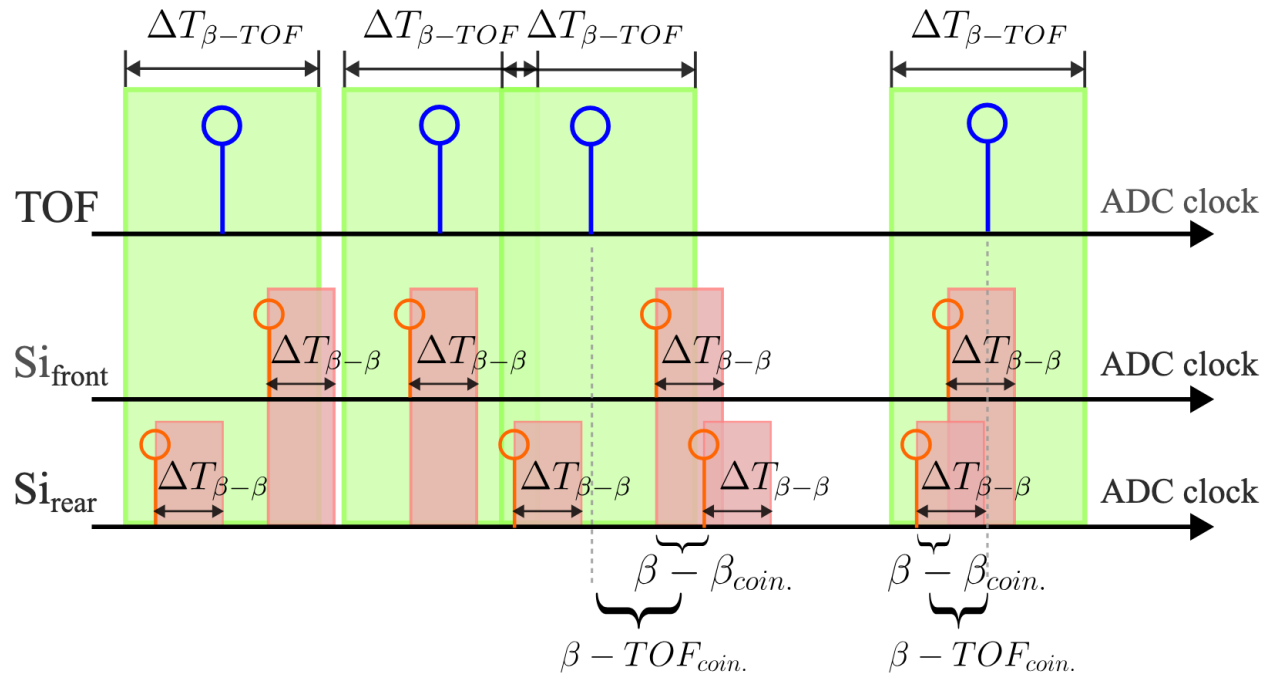

W. Xian *et al.* Front. Phys. 13:1644477

Results 2020-2024

W. Xian, S. Chen et al., Phys. Rev. C 109, 035804 (2024)

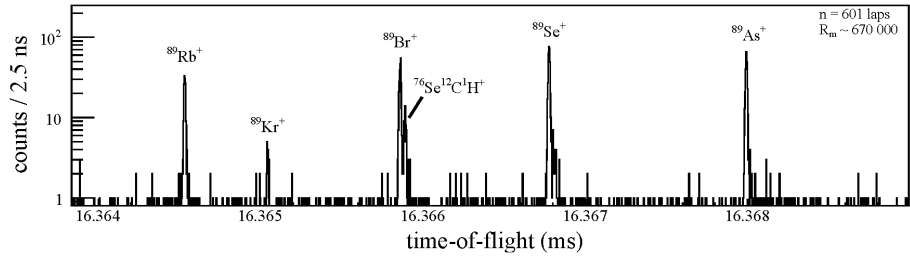

35 isotopes!
New: $^{88,89}\text{As}$

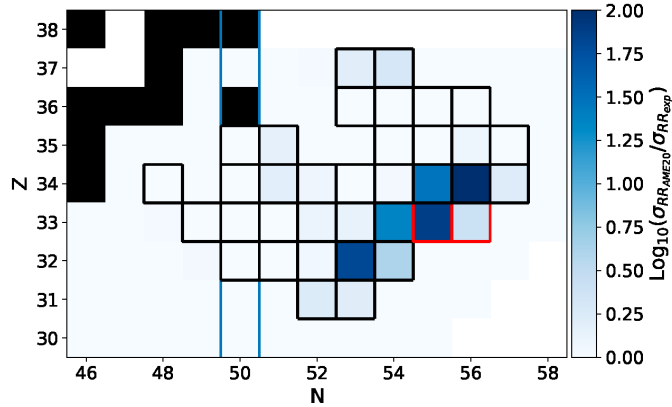

D.S. Hou, A. Takamine et al., Phys. Rev. C 108, 054312 (2023)

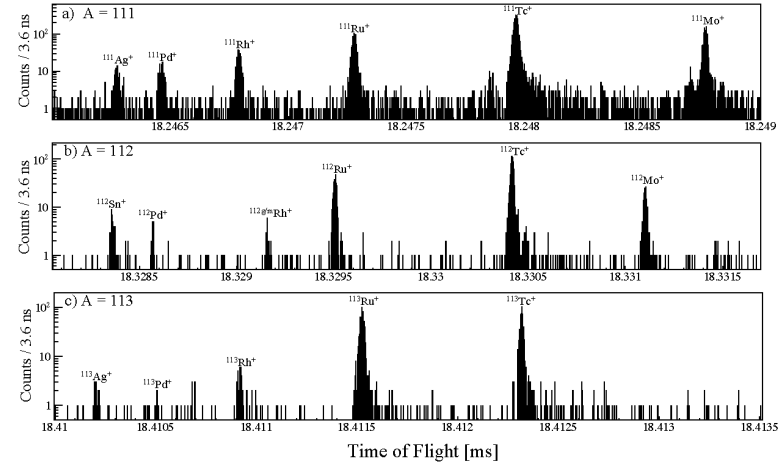

14 isotopes!
New: ^{112}Mo



M. Rosenbusch et al., Nucl. Instr. Meth. A 1047, 167824 (2023)

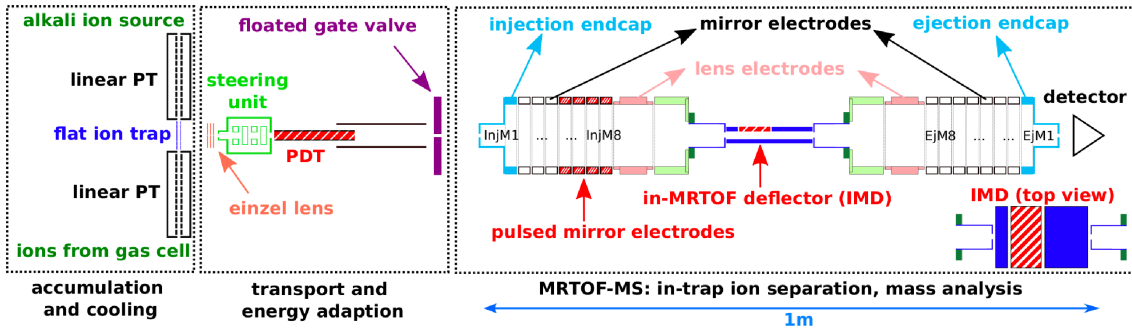

S. Iimura, M. Rosenbusch et al., PRL 130, 012501 (2023)

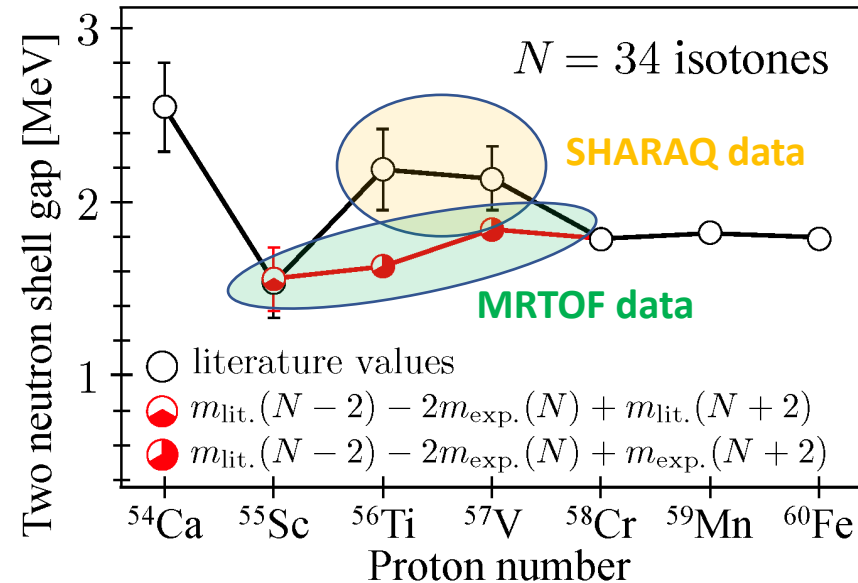

19 isotopes!
New: N=34 shell gap



Status heavy p-rich 2026

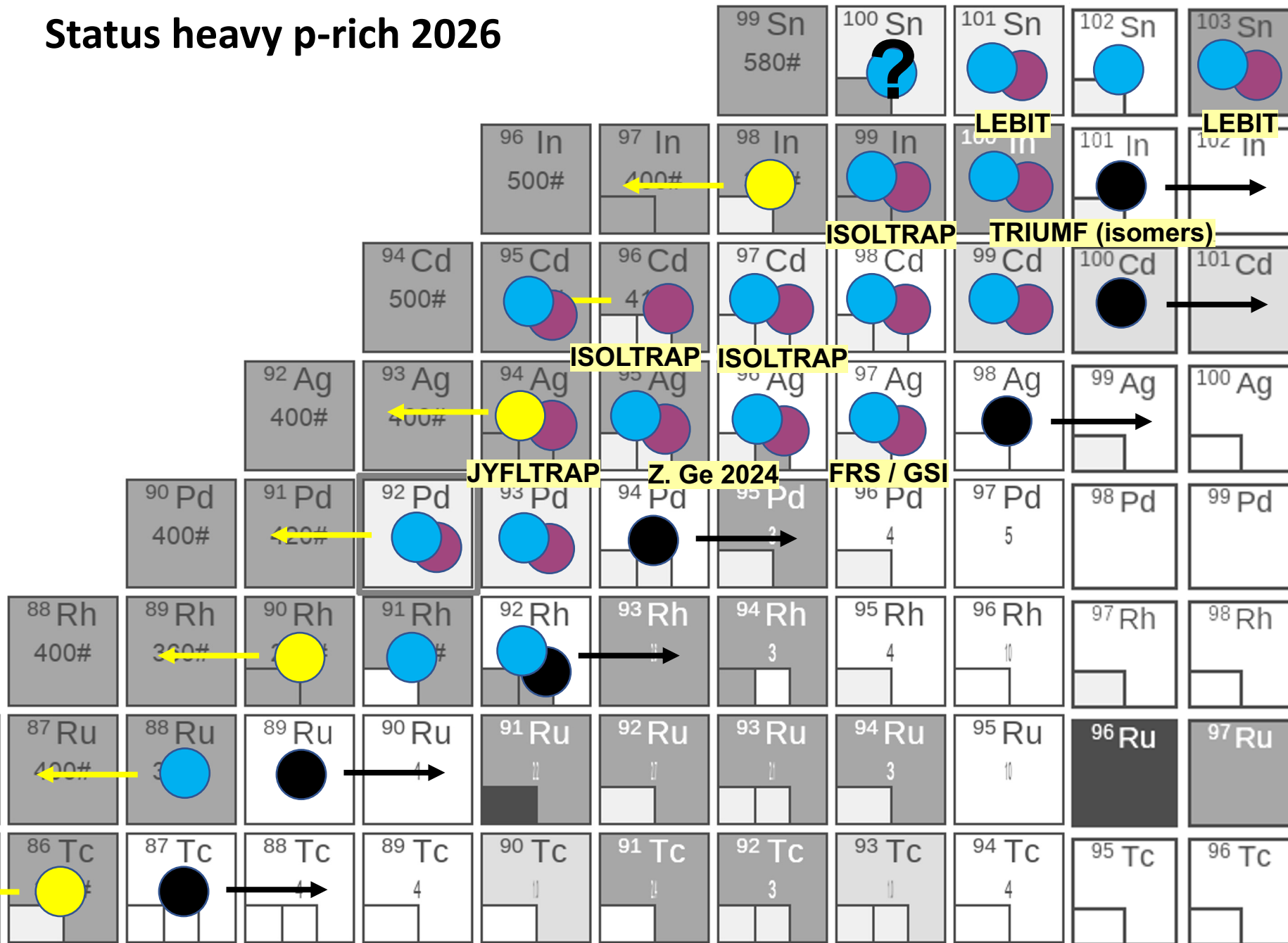

Overview:

High-precision mass measurements of $N=Z$ around ^{100}Sn

-  Accomplished (new or improved)
-  Still to do
-  Known by other exp.
-  Well known

^{124}Xe fragmentation

Data of two experiments combined:

- Parasitic run PE24
- Main experiment RIBF205(R1)

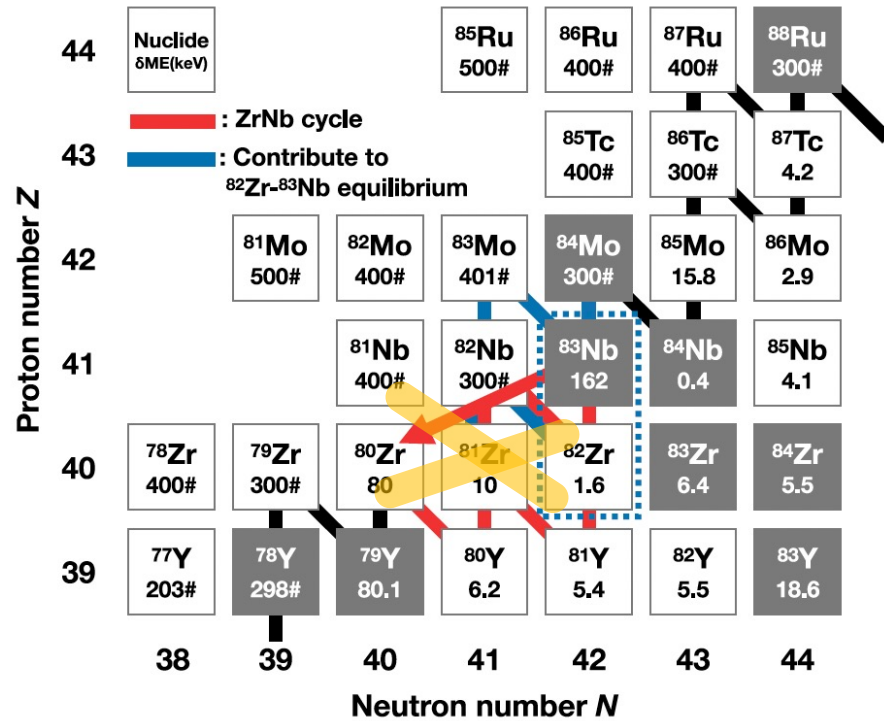

Precision Mass Measurements around ^{84}Mo Rule Out ZrNb Cycle Formation in the Rapid Proton-Capture Process at Type I X-Ray Bursts

S. Kimura^{1,*}, M. Wada^{1,†}, C. Y. Fu,^{2,3} N. Fukuda,² Y. Hirayama¹, D. S. Hou,^{1,3} S. Iimura^{2,4}, H. Ishiyama², Y. Ito^{5,‡}, S. Kubono^{2,6}, K. Kusaka,² S. Michimasa², H. Miyatake¹, S. Nishimura², T. Niwase⁷, V. Phong², M. Rosenbusch², H. Schatz⁸, P. Schury¹, Y. Shimizu,² H. Suzuki,² A. Takamine^{2,7}, H. Takeda,² Y. Togano², Y. X. Watanabe¹, W. D. Xian^{1,3}, Y. Yanagisawa,² T. T. Yeung,^{2,9} M. Yoshimoto², and S. Zha^{2,3}

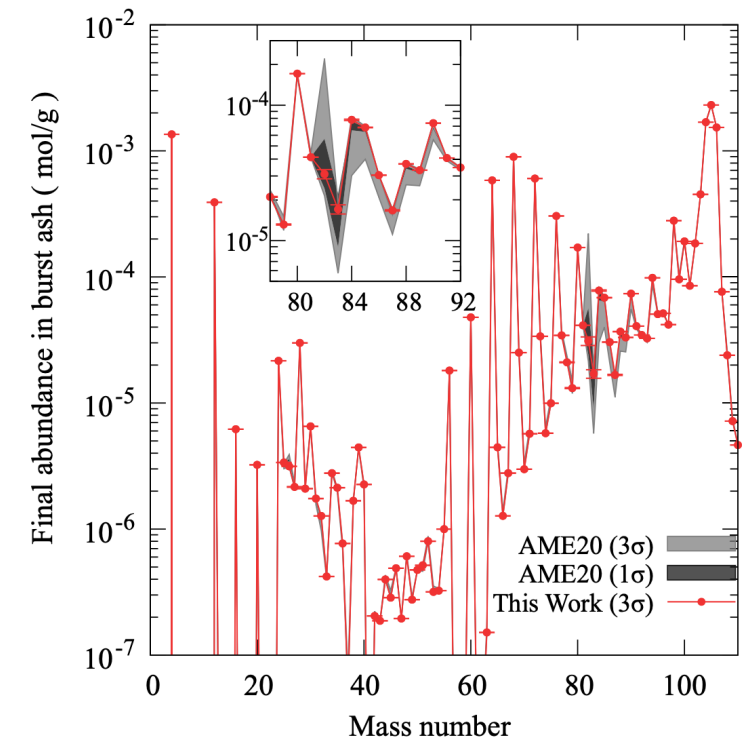
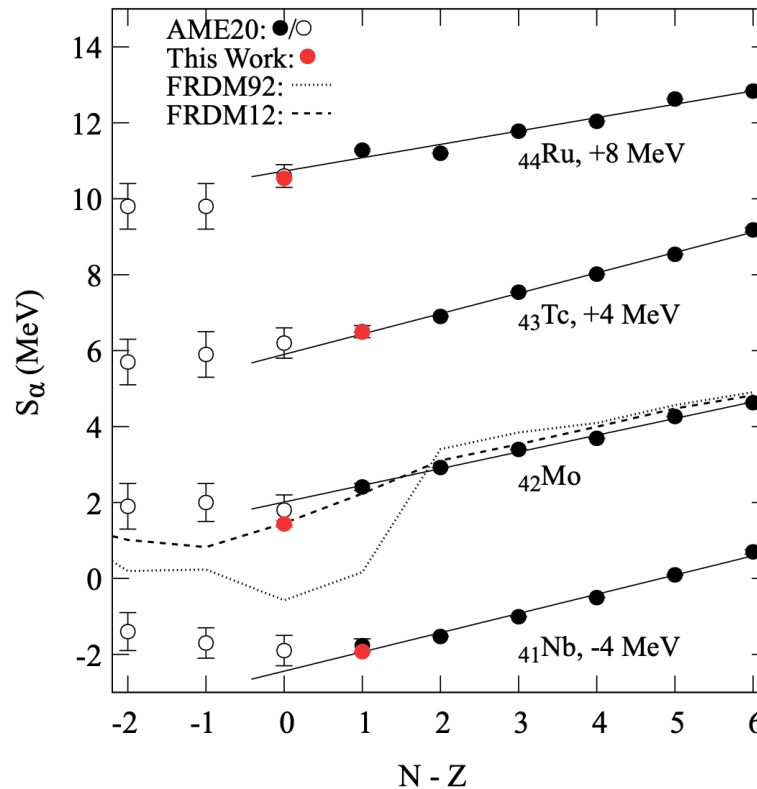

First direct mass measurements of ^{91}Rh , ^{92}Pd , and ^{96}Cd

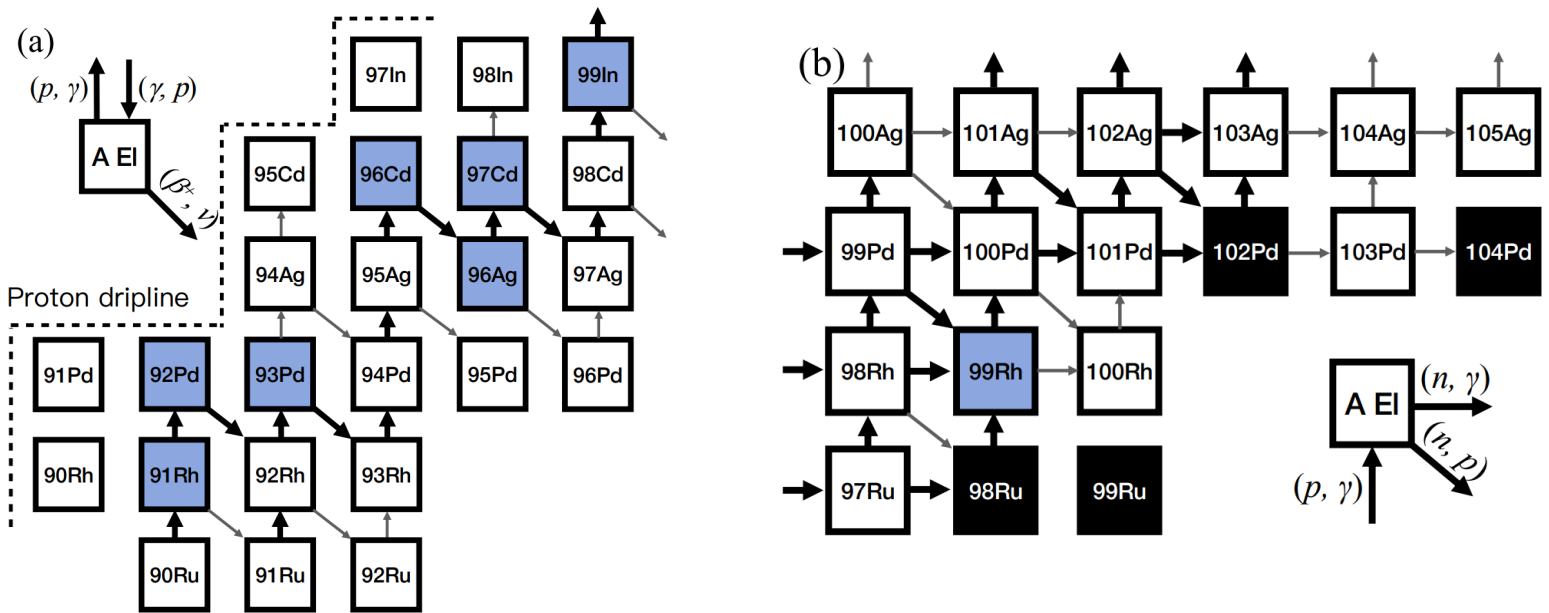
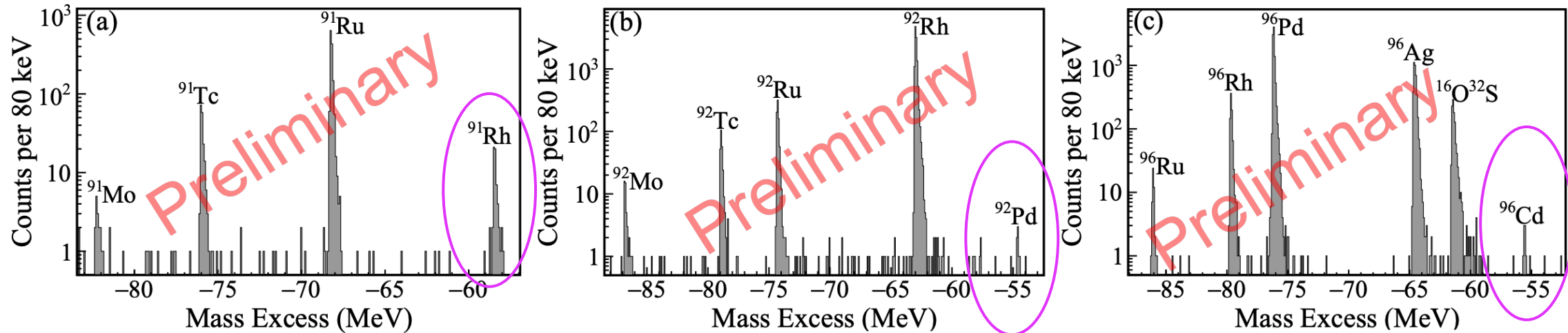

X-ray bursts and Supernova Nucleosynthesis

- rp-process abundances
- vp-process abundances
- See more at ARIS26 in Japan!

D. S. Hou et al., under review at Phys. Rev. Lett. (available on arxiv)

Parasitic run June 2025 (RIBF 249 / 234 PE)

^{70}Zn fragmentation

Closing the gap of ^{57}Ti 🥰

- High-precision by ZD MRTOF-MS
- AME2020

B_{ρ} -TOF: S. Michimasa et al., Z. Meisel et al.

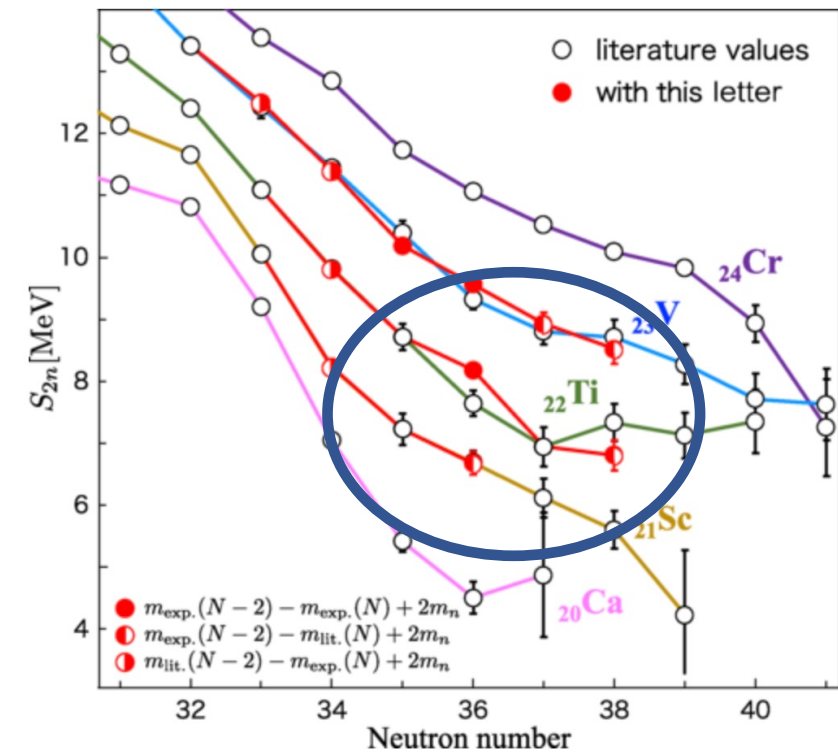

S. Iimura, M. Rosenbusch et al., PRL 130, 012501 (2023)

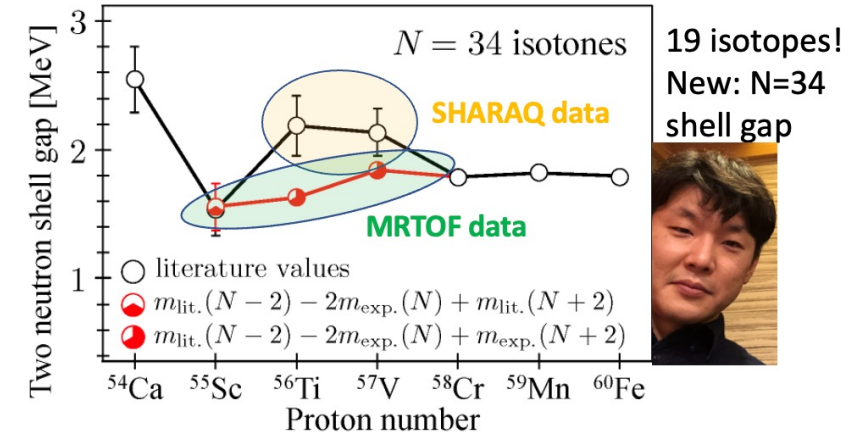

55V	56V	57V	58V	59V	60V	61V	62V	63V
●	●	●	●	●	→			
54Ti	55Ti	56Ti	57Ti	58Ti	59Ti	60Ti	61Ti	62Ti
●	●	●	😭	●	→			
53Sc	54Sc	55Sc	56Sc	57Sc	58Sc	59Sc	60Sc	61Sc
●	●	●	→					
52Ca	53Ca	54Ca	55Ca	56Ca	57Ca	58Ca	59Ca	60Ca

TOF beta-gamma

T. T. Yeung et al RIKEN Accel. Prog. Rep. 54, 2021

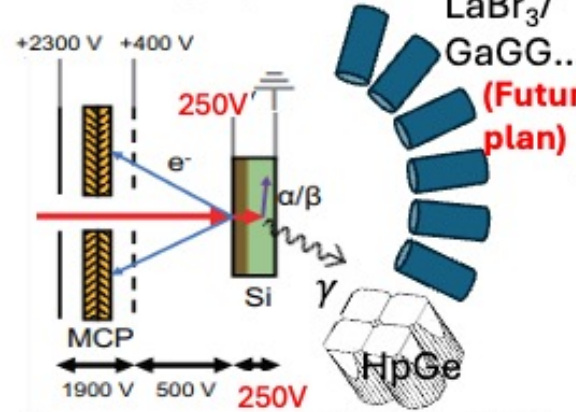
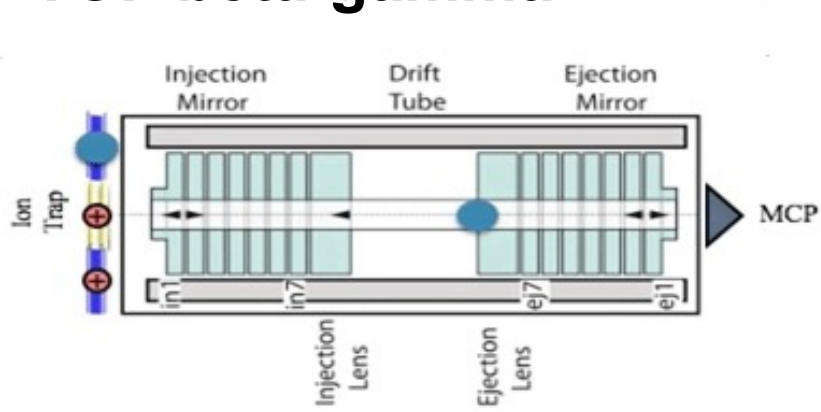

16 ch. CAEN V1730 digitizer

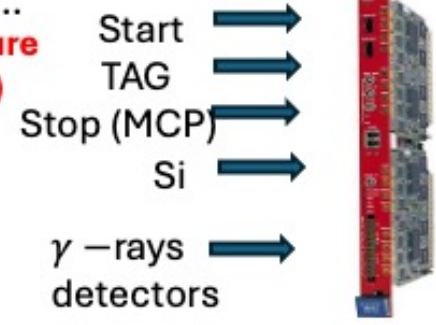

Beta-TOF correlated spectroscopy of n-rich Sn isotopes

- Hamamatsu MCP F2223-21SH
- [1 mm thick PIPS Si detector]

^{135}Sn (325 TOF counts), $T_{1/2}^{\text{lit}} = 514(30)$ ms

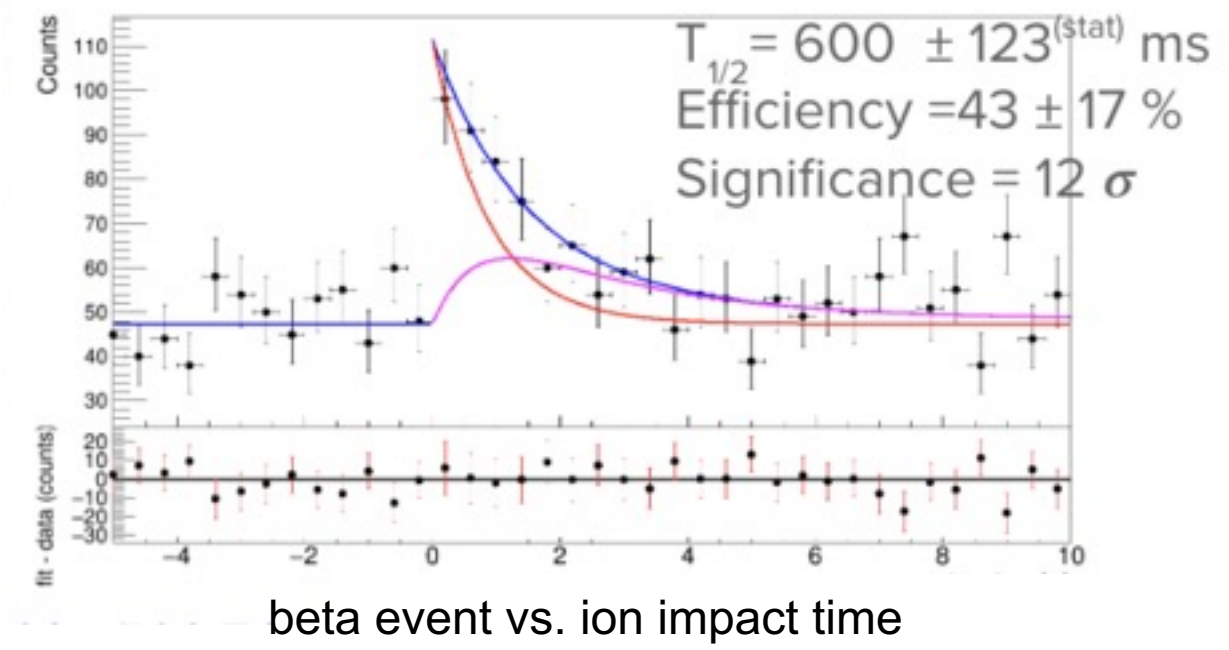
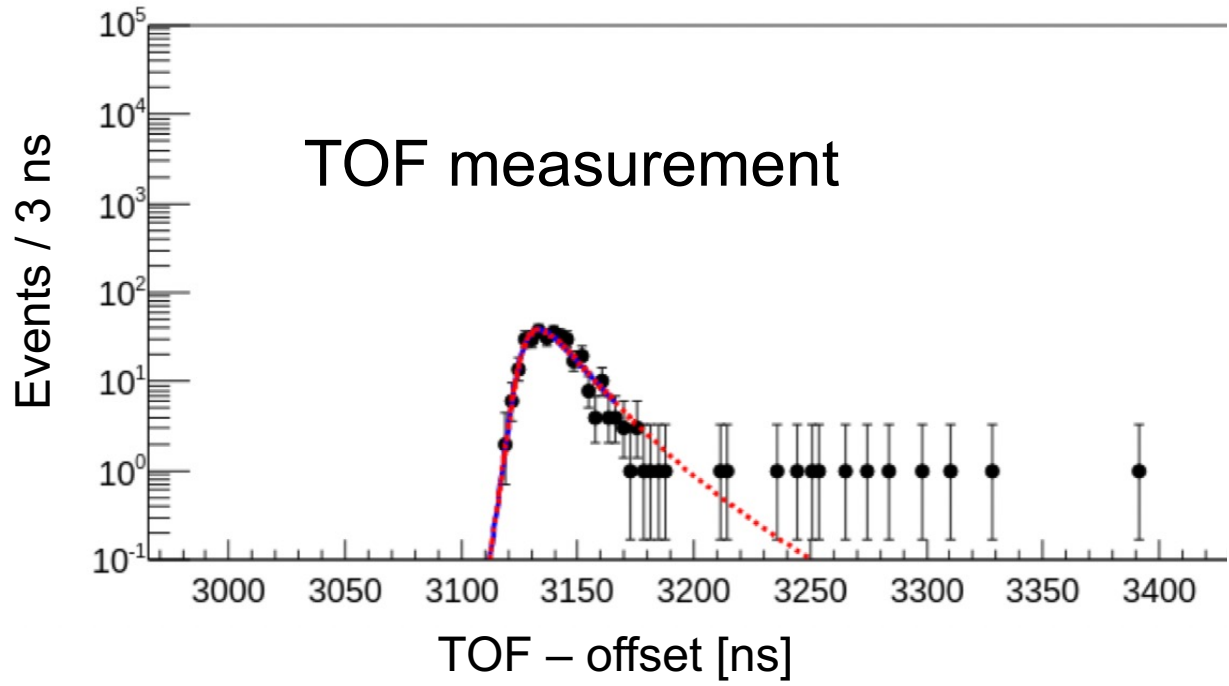

Challenges for annular-MCP designs

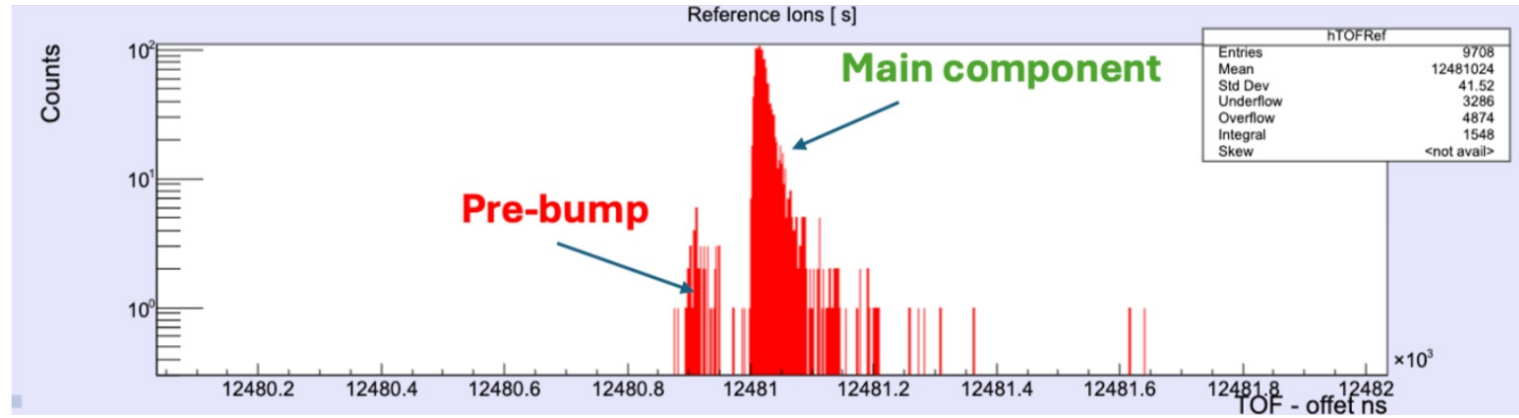
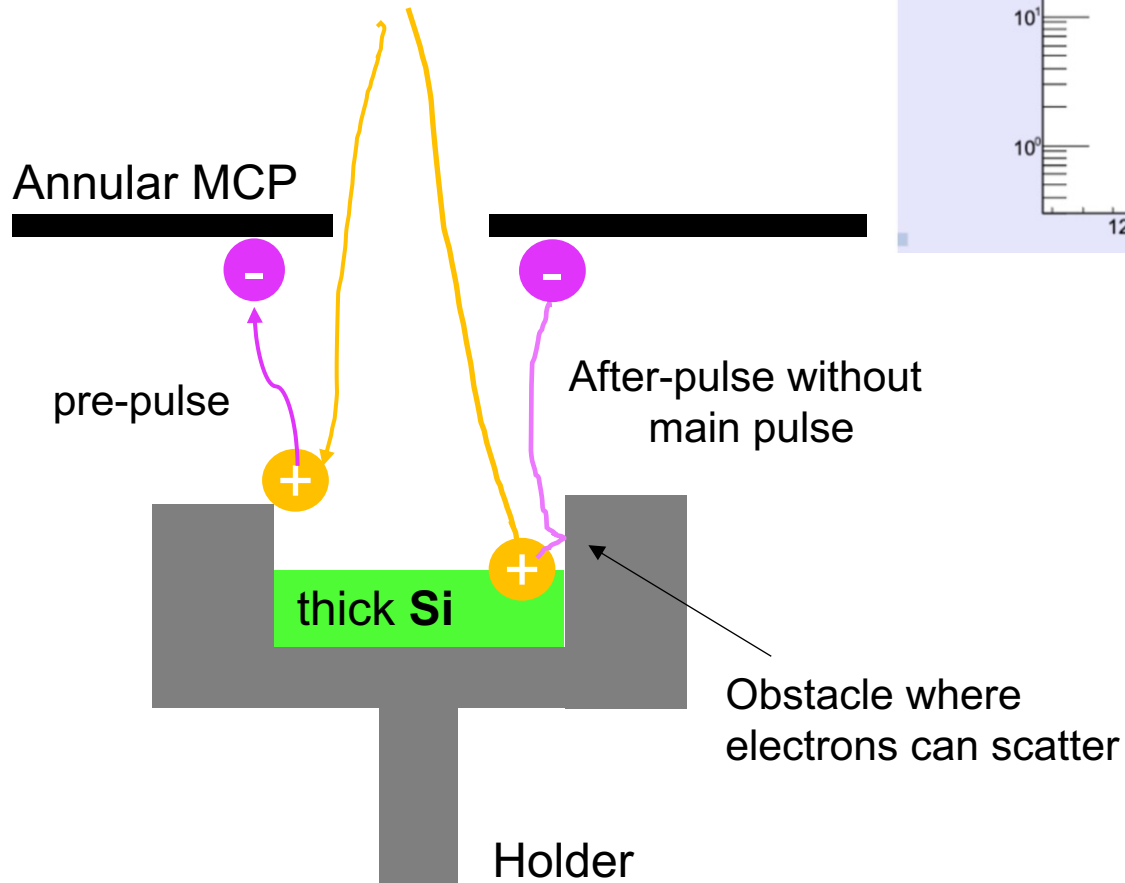

- TOF signal had issues in shape and width
- MRP decreased slightly as compared to MagneTOF
- Pre-bump and delayed pulses have been seen
- Pre-bump issue solved by focusing
- New design to solve electron scattering

We need high MRP for isomer-tagged β - γ spectroscopy

Motivation for isomer-selected decay spectroscopy

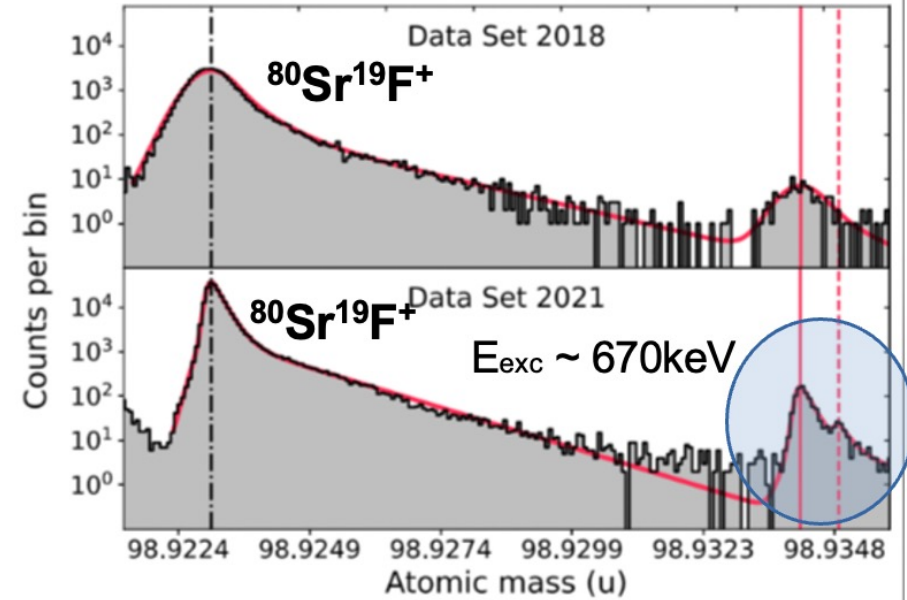
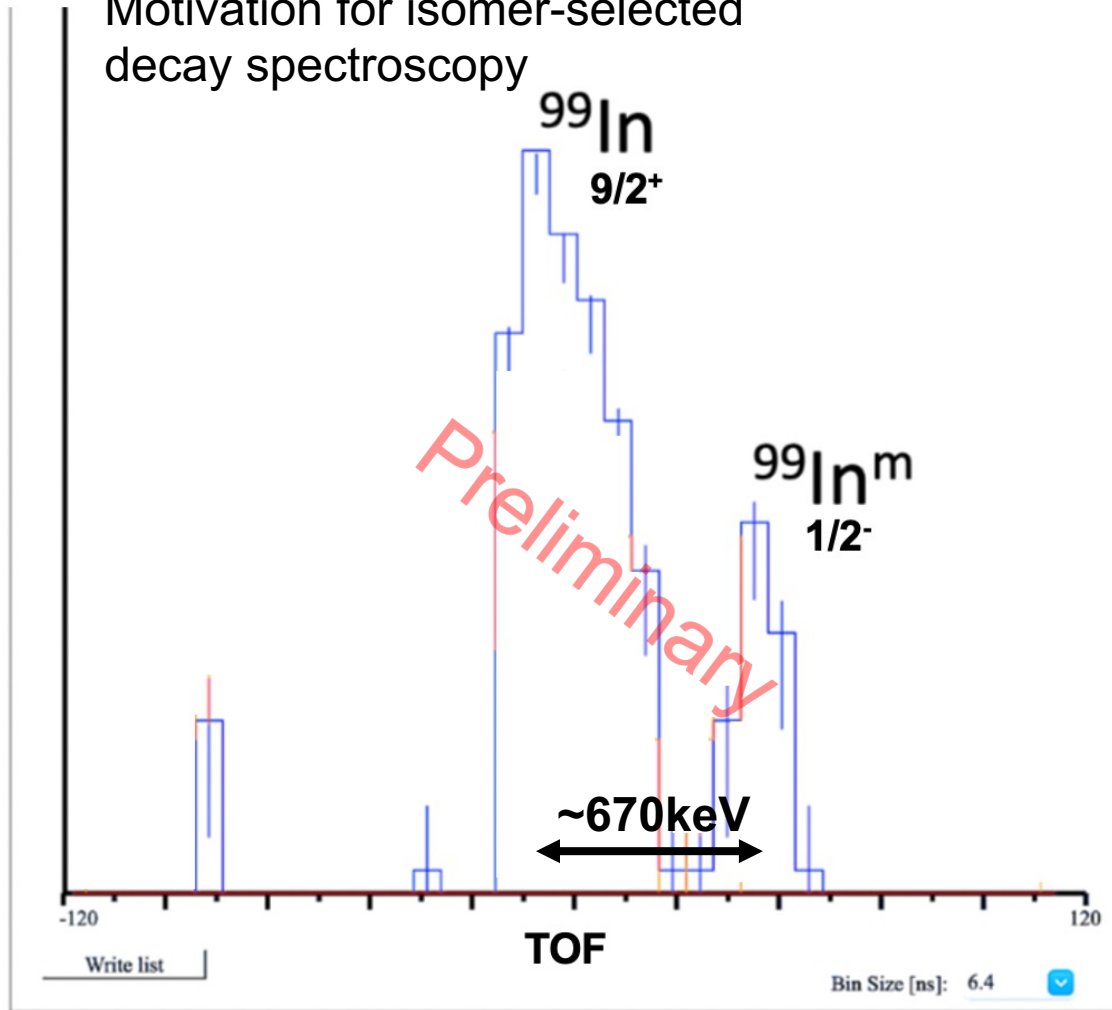

Spectrum from ISOLTRAP MRTOF

L. Nies et al., Phys. Rev. Lett.
131, 022502 (2023)



We need high MRP for isomer-tagged β - γ spectroscopy

News from a 50-cm system

- Alignment improved
- Resolving power same as for large-scale MRTOF-MS
- Long flight times without major ion losses

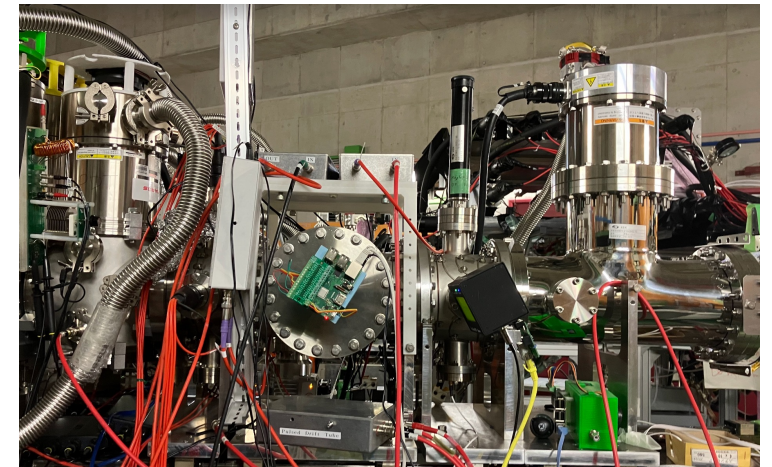

$^{85}\text{Rb}^+$ at 1735 laps (36 hours accumulation)

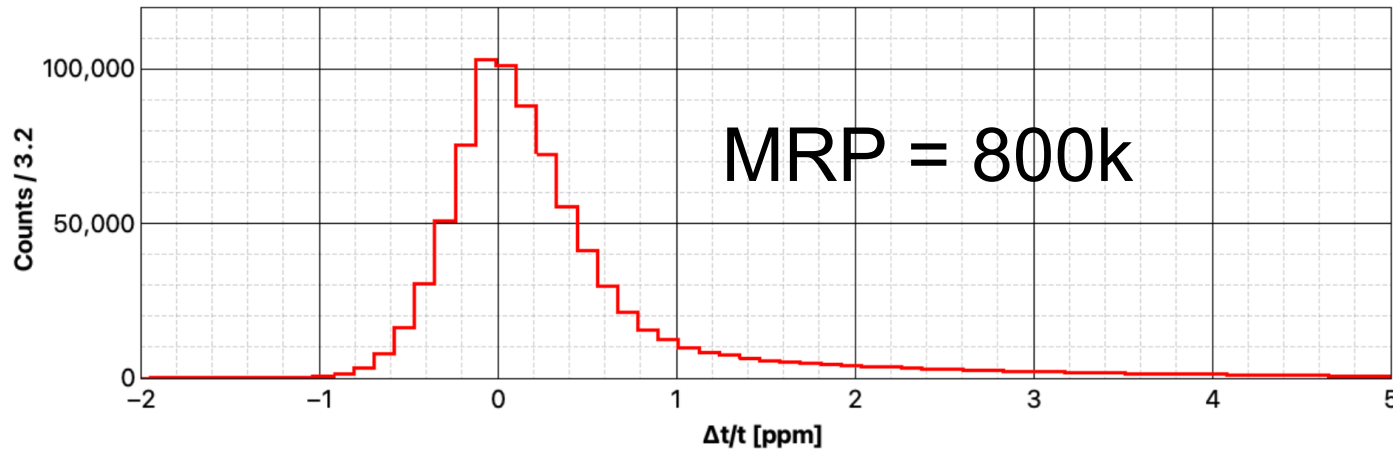

High MRP in a small system is possible!

Run #103

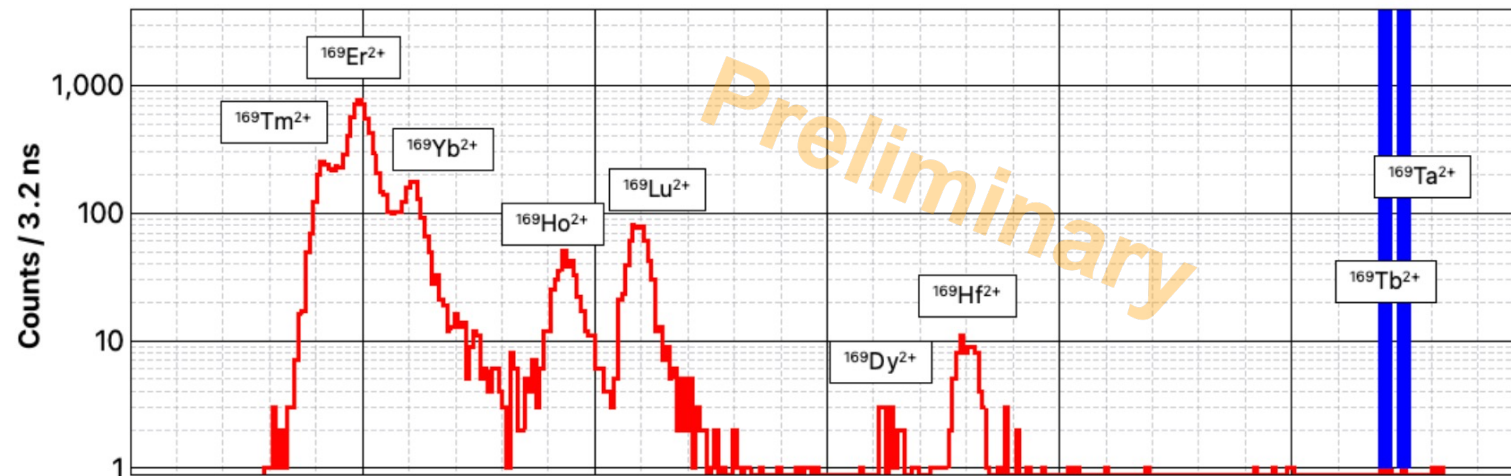

Present efforts to develop an efficient production method

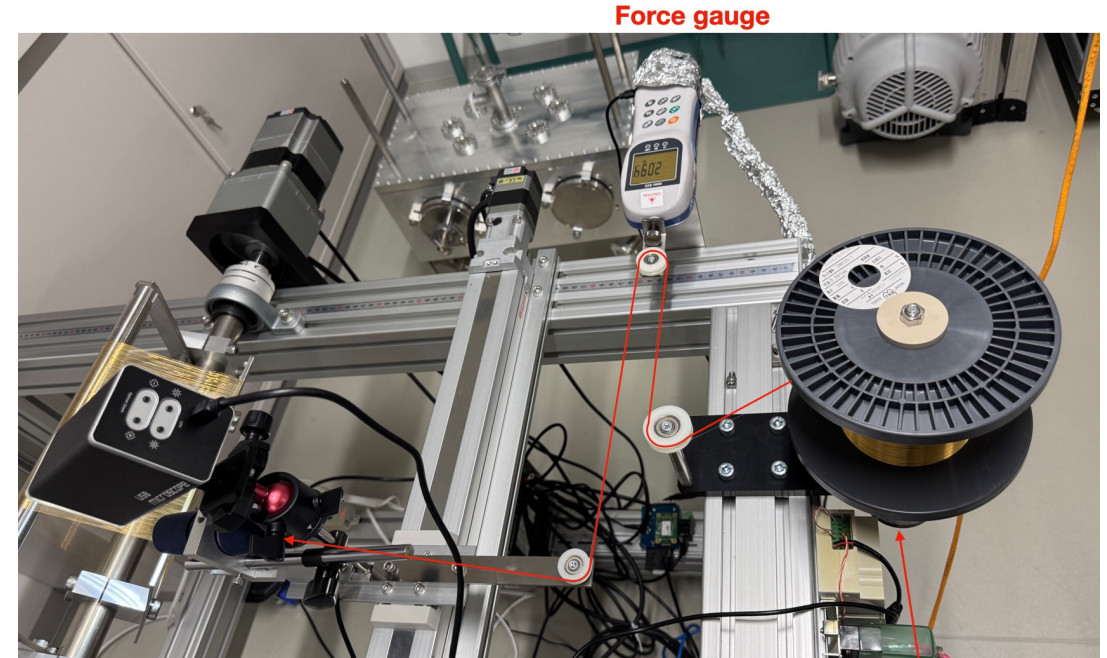

Force gauge
Bobbin motor is PID controlled

Goal:

- Automatic weaving of wire carpet
- Easy and time saving reproduction
- Abundant availability for testing and destroying

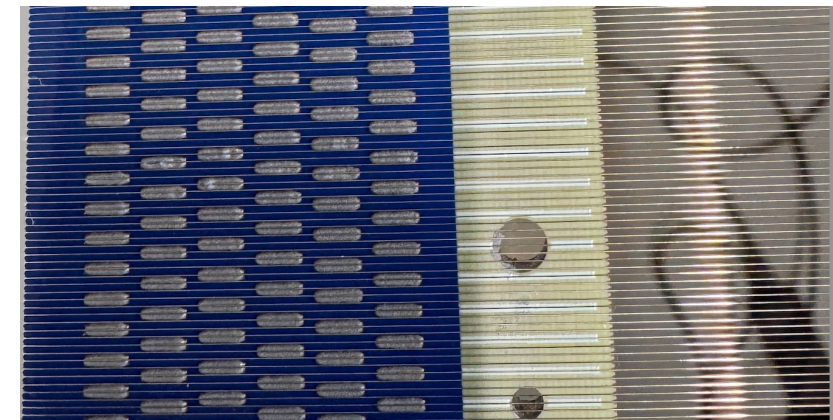
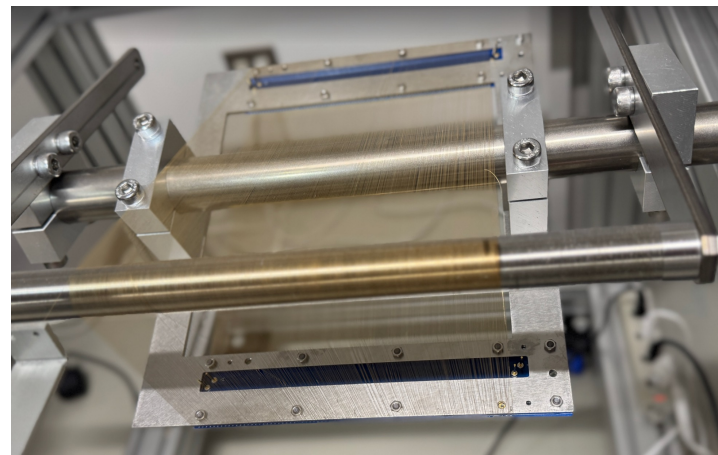

Main developer: A. Takamine

Dealing with rare events and contaminated spectra

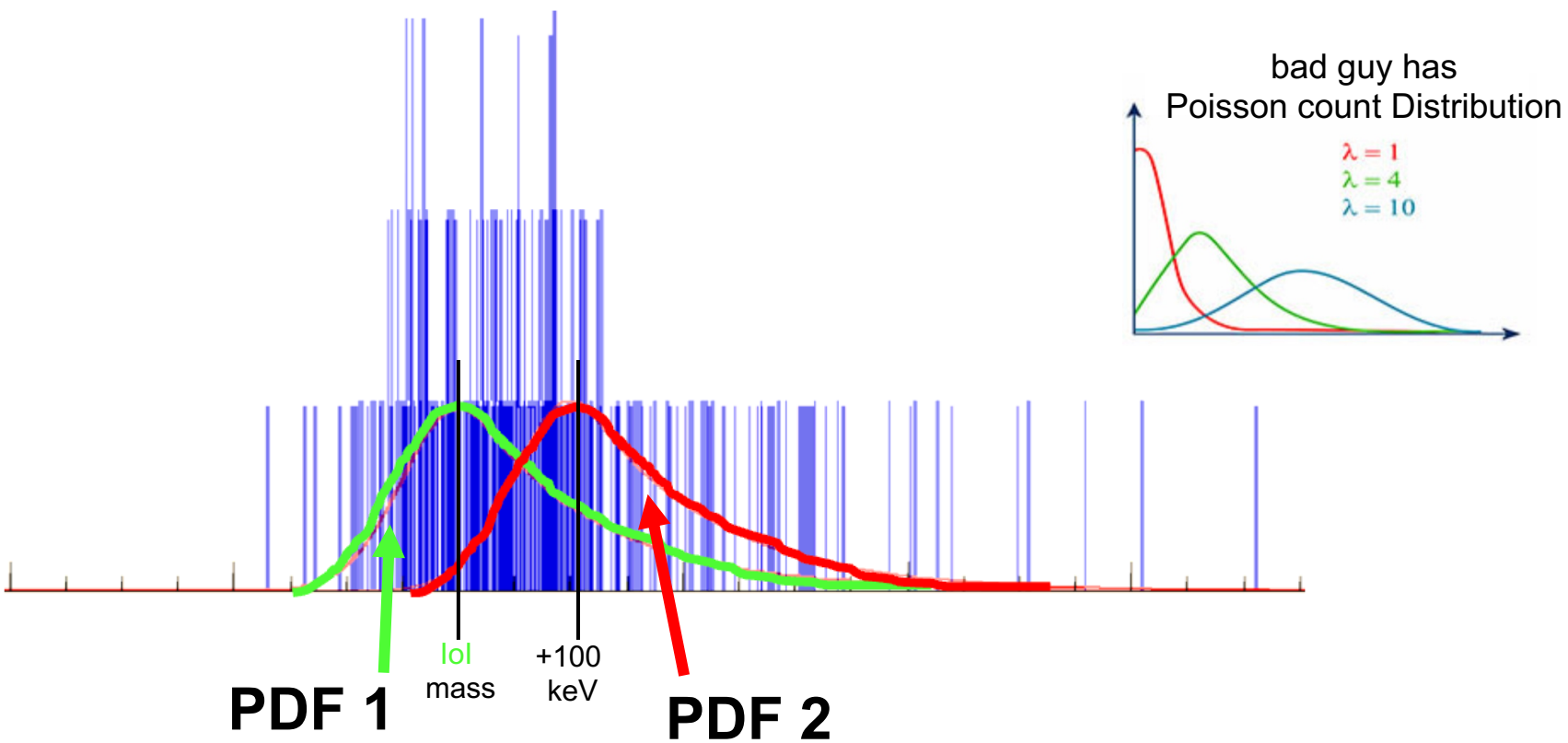

- The amount of the **contaminant** is unknown but the average rate is known
- The position of the **lol** is unknown
- The position of the **contaminant** is known
- The PDF of each peak is known

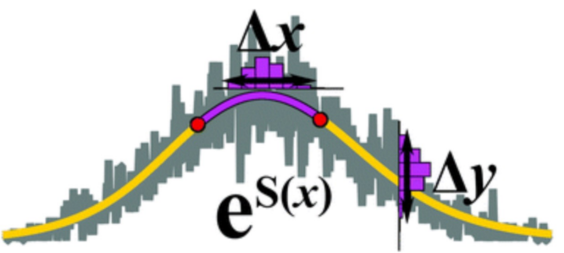

Previous work:

- Assigning the uncertainty for arbitrary model fit functions

A. Chudinov, M. Rosenbusch et al.
Analyst, 2020,**145**, 3401-3406

Model independent peak fitting and uncertainty assignment for high-precision time-of-flight mass spectrometry

[Aleksy Vladimirovich Chudinov](#), ^{*a} [Marco Rosenbusch](#), ^b [Vyacheslav Ivanovich Kozlovskiy](#), ^a [Valeriy Vladislavovich Raznikov](#), ^a [Peter Schury](#), ^b [Michiharu Wada](#) ^b and [Hermann Wollnik](#) ^c



Mass uncertainty with rare events and contamination

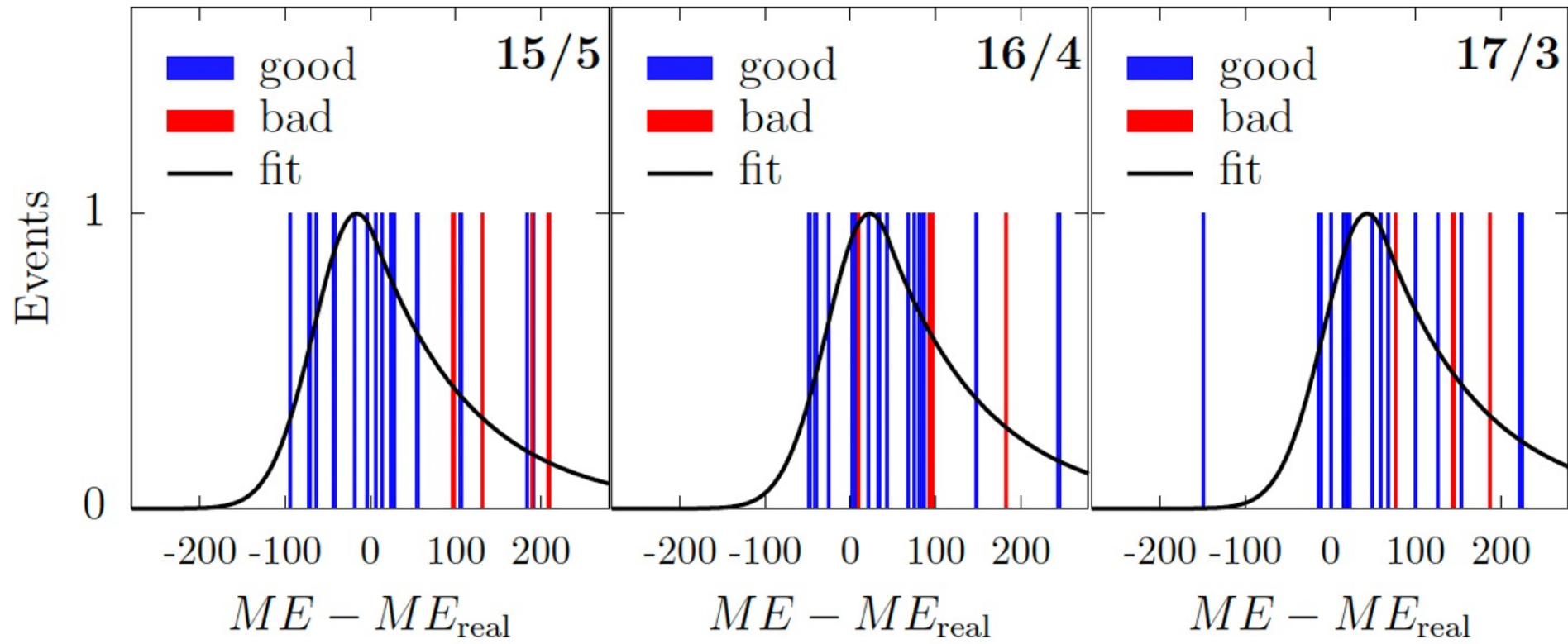

Mass uncertainty with rare events and contamination

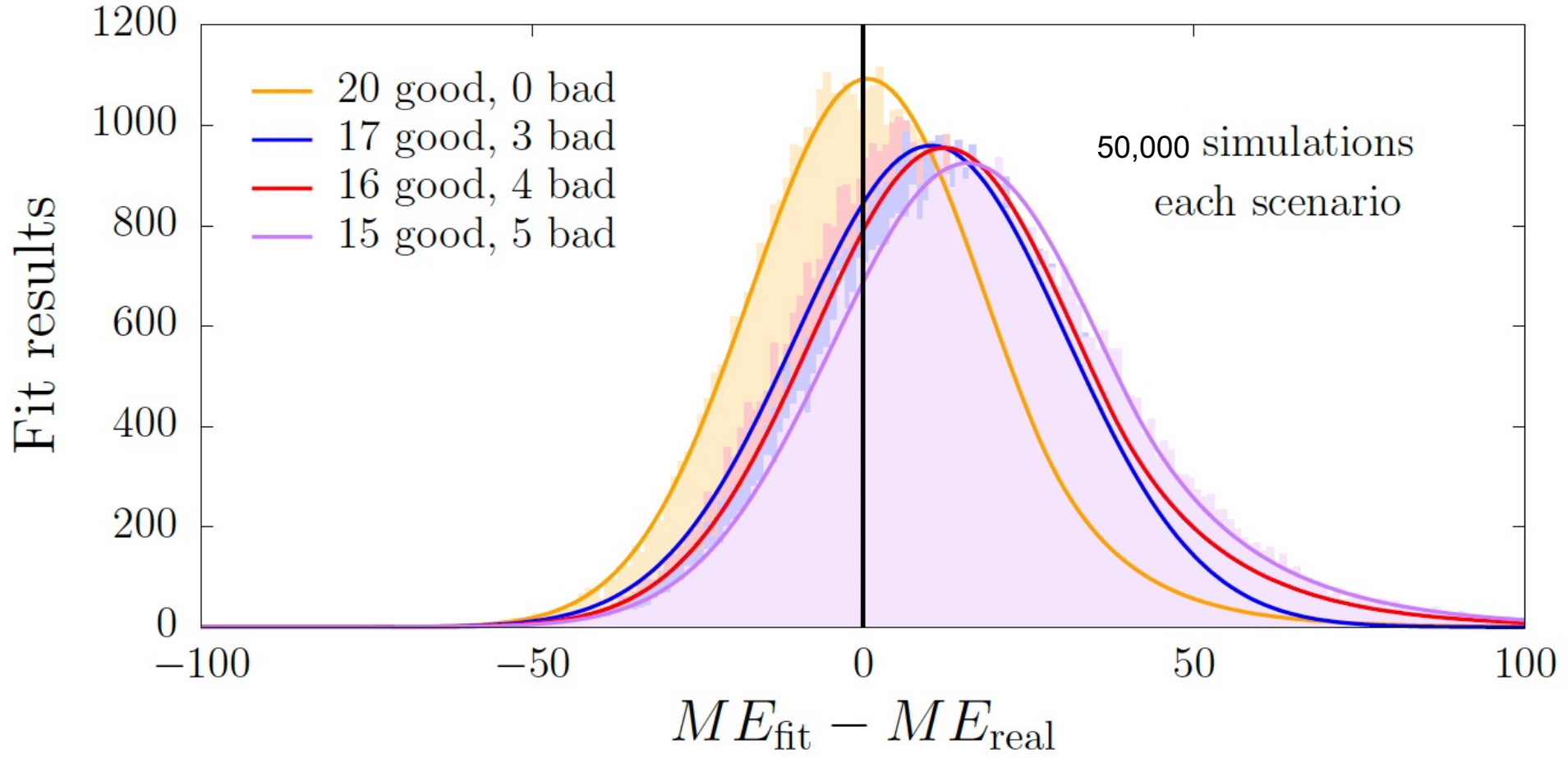

Summary

- The ZD MRTOF-MS became successful for nuclear mass measurements
→ 75 isotopes published! **4 PhDs have graduated!**
- Problems in case of low production rates are tackled by efficient use of a through-beam gas cell, an IMD system, and beta-correlated mass spectroscopy
- Successful mass measurements of n-deficient isotopes at and below 100Sn , and ^{57}Ti
- Development of decay-correlated mass spectroscopy /decay detector
- Development of pure-isomer decay spectroscopy

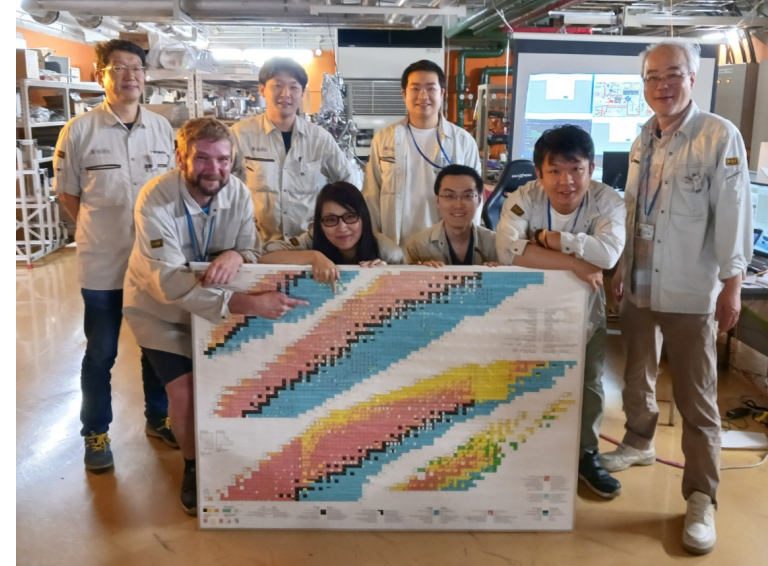
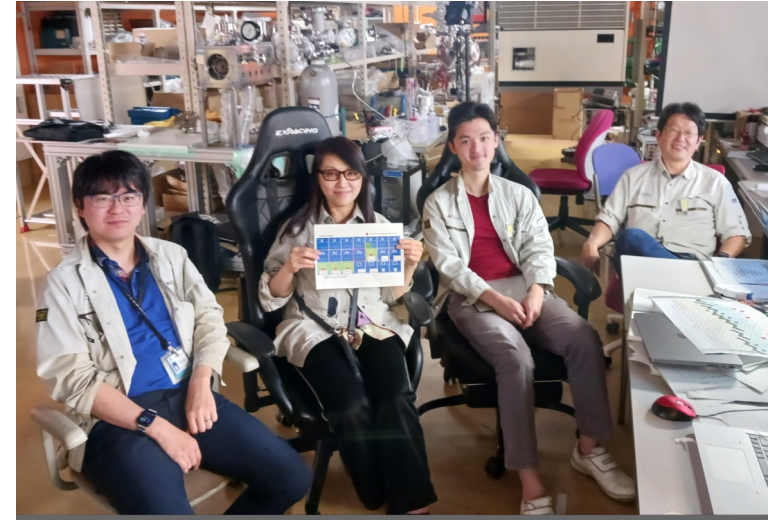



香港大學

THE UNIVERSITY OF HONG KONG



2020 first ZD MRTOF commissioning



Thanks to:

- KISS collaboration
- SHE mass collaboration
- ZD MRTOF collaboration



