

Testing static octupole deformation in radium isotopes

Aiko Takamine

I have moved to a new university

Kyushu Univ.



SMI-2017 will be held here

RIBF

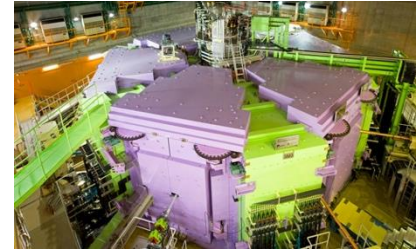

Science Tokyo



Nakamura



Fujioka

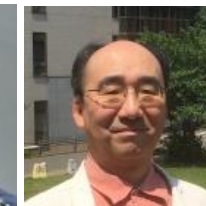

Jido



Sekizawa

...good timing to start a new thing, right?

Electromagnetic moments of nuclei

A nucleus is a finite-size quantum system with a charge distribution $\rho(\mathbf{r})$ and a current distribution $\mathbf{J}(\mathbf{r})$.

Electromagnetic multipole moments are the coefficients obtained by classifying them according to angular momentum and rotational symmetry.

$$\lambda Q_{\lambda m} \equiv \int d^3r \rho(\mathbf{r}) r^\lambda Y_{\lambda m}(\hat{\mathbf{r}}) \quad \text{Electric multipole operator } E\lambda$$

λ : multipole rank (angular momentum)
 m : magnetic quantum number

$$\lambda M_{\lambda m} \equiv \frac{1}{c} \int d^3r r^\lambda \left[\mathbf{Y}_{\lambda m}^{(\lambda)}(\hat{\mathbf{r}}) \cdot \mathbf{J}(\mathbf{r}) \right]_{\lambda m} \quad \text{Magnetic multipole operator } M\lambda$$

Here, $\lambda \leq 2I$

multipole	parity	T-symmetry
$E\lambda$	$(-1)^\lambda$	even
$M\lambda$	$(-1)^{\lambda+1}$	odd

To get $\langle IM | \hat{O} | IM \rangle \neq 0$, Only even electric multipoles and odd magnetic multipoles can become static moments.

	T even	T odd
P even	$E0, E2, E4, \dots$ (charge)	$M1, M3, M5, \dots$ (current)
P odd	$E1, E3, \dots$ (P-forbidden)	$M2, M4, \dots$ (P,T-forbidden)

odd \rightarrow vanishes for a parity eigenstate

T odd \rightarrow can be compensated by spin (T odd)

Rotational symmetry \rightarrow tensors of the same rank are needed

Electromagnetic moments of nuclei

$$\lambda Q_{\lambda m} \equiv \int d^3r \rho(\mathbf{r}) r^\lambda Y_{\lambda m}(\hat{\mathbf{r}}) \text{ Electric multipole operator } E\lambda$$

λ : multipole rank (angular momentum)
 m : magnetic quantum number

Here, $\lambda \leq 2I$

$$E0: Q_{00} = \int d^3r \rho(\mathbf{r}) = Ze \text{ charge}$$

$$E1: \mathbf{d} = \int d^3r \rho(\mathbf{r}) \mathbf{r} \text{ EDM}$$

$$E2: Q_{2m} \sim \int d^3r \rho(\mathbf{r}) (3z^2 - r^2) \text{ deformation (prolate/oblate)}$$

$$E3: Q_{30} \propto \int d^3r \rho(\mathbf{r}) (2z^3 - 3zx^3 - 3zy^2) \leftarrow z\text{-symmetric case } \mathbf{P}\text{-violation (pear shape)}$$

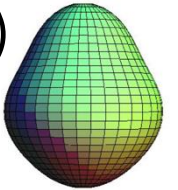
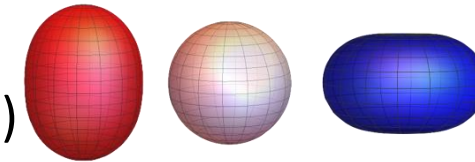

$$\lambda M_{\lambda m} \equiv \frac{1}{c} \int d^3r r^\lambda \left[\mathbf{Y}_{\lambda m}^{(\lambda)}(\hat{\mathbf{r}}) \cdot \mathbf{J}(\mathbf{r}) \right]_{\lambda m} \text{ Magnetic multipole operator } M\lambda$$

$$M1: \mu = \frac{1}{2} \int d^3r \mathbf{r} \times \mathbf{J}(\mathbf{r}) \text{ magnetic moment}$$

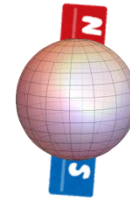

$$M3: \Omega \propto \int d^3r [(3z^2 - r^2)(\mathbf{r} \times \mathbf{J})_z] \leftarrow z\text{-symmetric case, static deformation } \text{ octupole moment}$$

Electromagnetic moments of nuclei

Even though both are called octupole, E3 and M3 are different.

$$E3: Q_3 \sim ZeR^3\beta_3$$

$$R \sim 1.2A^{1/3} \text{ fm}$$
$$\beta_3 \sim 0.1 \text{ (Ra, Rn)}$$

$$M3: \Omega \sim g_R IR^2\beta_3$$

$$g_R \sim \frac{Z}{A}$$

Compared with E3, M3 has one less spatial dimension.

Microscopic origin: opposite-parity pairs with $\Delta\ell = \Delta j = 3$ lie near the Fermi surface



large octupole matrix elements



octupole correlations grow collectively



the mean field breaks parity



parity doublets appear at low excitation through quantum tunneling

"Large" octupole correlation

E3-only nuclei

→ strong octupole correlation,
but the currents do not align at low spin

M3-only nuclei

→ weak or non-collective octupole correlation,
but a distorted current pattern

Both E3 and M3 large

→ strong octupole correlation and also high
spin

Atomic hyperfine structure

$$E_F = A \frac{K}{2} + B \frac{3K(K+1) - I(I+1)J(J+1)}{4 \cdot 2I(2I-1)J(2J-1)}$$

μ Q

$$K = F(F+1) - I(I+1) - J(J+1)$$

$$+ C \frac{5K^3 + 4K^2 + \frac{4}{5}(-3I(I+1)J(J+1) + I(I+1) + J(J+1) + 3) - 4I(I+1)(J+1)}{4 \cdot I(I-1)(2I-1)J(J-1)(2J-1)}$$

Ω

+D....,

See also Ruben's review: Atoms 2024, 12, 60

Test case:

$I=3/2, J=3/2$

$A=400 \text{ MHz}, B=150 \text{ MHz}, C=3 \text{ MHz}$

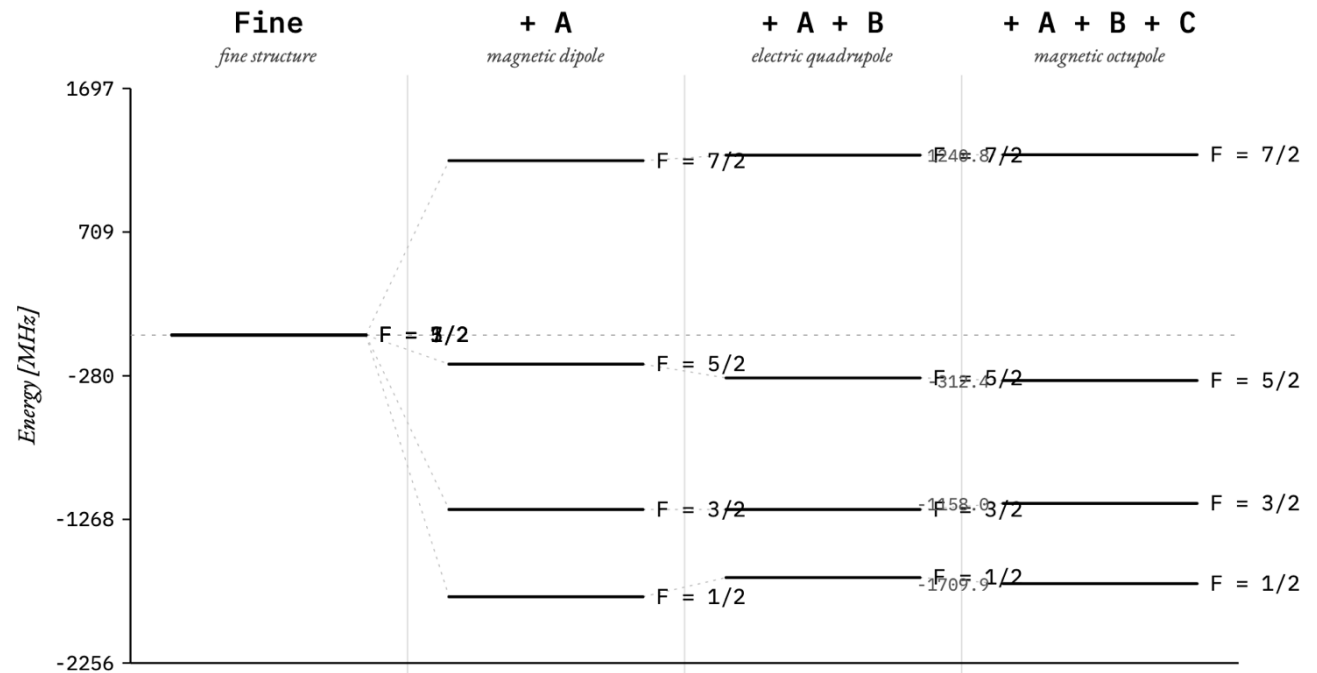

$^{173}\text{Yb}(I=5/2^-)$ case

Measurements of Ω :

A. K. Singh et al., PRA 87, 012512 (2013)

R. O. de Groote et al., PRA 103, 032826 (2021)

J. Jiang et al., PRL 136, 023001 (2026)

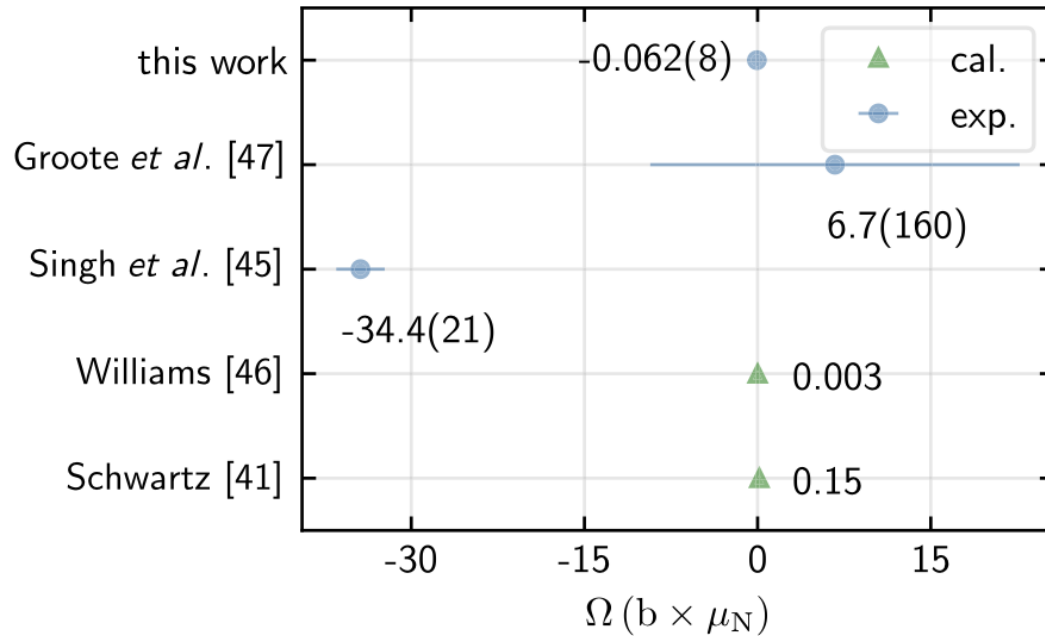

$\leftarrow C = 113(13)$ Hz in $5d^2D_{3/2}$

$^{172,174}\text{Yb}$ do not show the kind of exceptionally strong octupole collectivity seen in Ra, although non-negligible E3 strength does exist in them.

nature

Explore content ▾ About the journal ▾ Publish with us ▾

[nature](#) > [articles](#) > article

Article | Published: 08 May 2013

Studies of pear-shaped nuclei using accelerated radioactive beams

[L. P. Gaffney](#), [P. A. Butler](#) , [M. Scheck](#), [A. B. Hayes](#), [F. Wenander](#), [M. Albers](#), [B. Bastin](#), [C. Bauer](#), [A. Blazhev](#), [S. Bönig](#), [N. Bree](#), [J. Cederkäll](#), [T. Chupp](#), [D. Cline](#), [T. E. Cocolios](#), [T. Davinson](#), [H. De Witte](#), [J. Diriken](#), [T. Grahn](#), [A. Herzan](#), [M. Huyse](#), [D. G. Jenkins](#), [D. T. Joss](#), [N. Kesteloot](#), ... [M. Zielinska](#) + Show authors

[Nature](#) **497**, 199–204 (2013) | [Cite this article](#)

20k Accesses | 332 Citations | 193 Altmetric | [Metrics](#)

Figure 4: Graphical representation of the shapes of ^{220}Rn and ^{224}Ra .

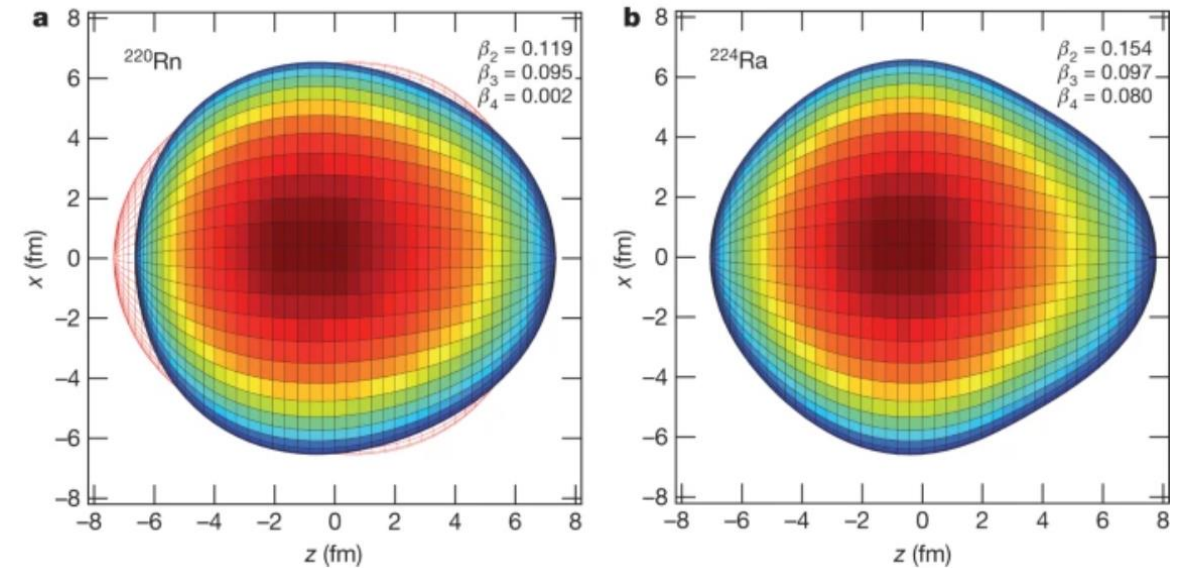

$\langle 2^+ || E3 || 1^- \rangle, \langle 2^+ || E3 || 3^- \rangle, \langle 2^+ || E3 || 5^- \rangle$
 Large $B(E3) \rightarrow$ pear shape

PHYSICAL REVIEW C **97**, 024309 (2018)

Laser-spectroscopy studies of the nuclear structure of neutron-rich radium

K. M. Lynch,^{1,*} S. G. Wilkins,² J. Billowes,² C. L. Binnersley,² M. L. Bissell,² K. Chrysalidis,^{3,4} T. E. Cocolios,⁵ T. Day Goodacre,^{2,3,†} R. P. de Groote,⁵ G. J. Farooq-Smith,⁵ D. V. Fedorov,⁶ V. N. Fedosseev,³ K. T. Flanagan,² S. Franchoo,⁷ R. F. Garcia Ruiz,² W. Gins,⁵ R. Heinke,⁴ Á. Koszorús,⁵ B. A. Marsh,³ P. L. Molkanov,⁶ P. Naubereit,⁴ G. Neyens,⁵ C. M. Ricketts,² S. Rothe,³ C. Seiffert,³ M. D. Seliverstov,⁴ H. H. Stroke,⁸ D. Studer,⁴ A. R. Vernon,² K. D. A. Wendt,⁴ and X. F. Yang⁵

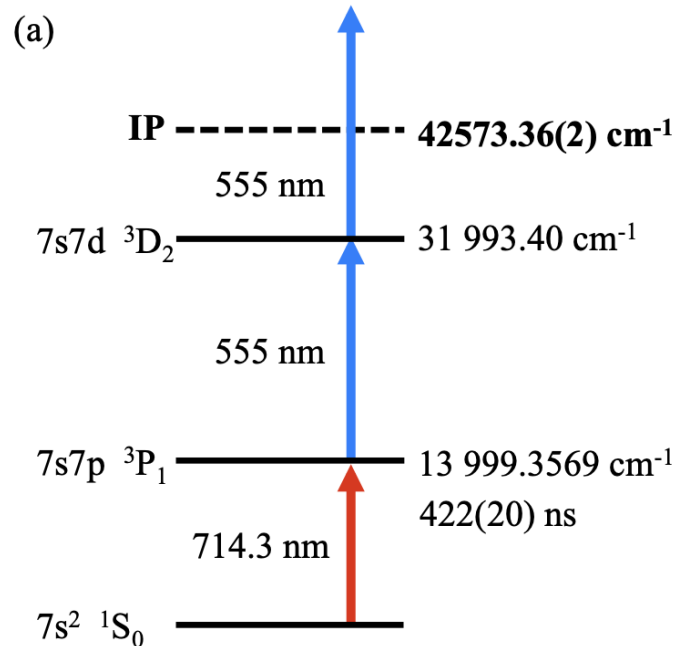

Laser spectroscopy of neutral ^{222–233}Ra (7s2 ¹S₀ → 7s7p ³P₁)

- Mean-square charge radii, μ and Q were measured systematically
- The odd-even staggering changes sign around $N = 136–138$ and the charge radius grows larger → maybe this indicates static octupole deformation?

Could ²²⁴Ra be a nucleus with both large E3 and large M3?

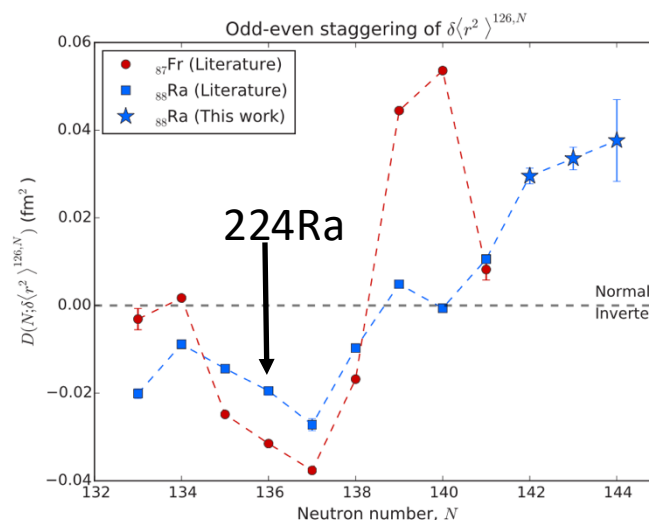

Ra case

T. Day Goodacre et al., Spectrochimica Acta Part B 150, 99 (2018)

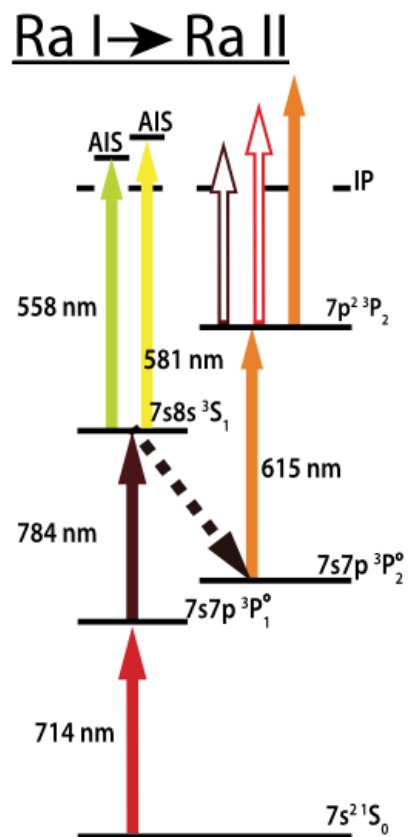

“...can be understood as resulting from the decay from the $7s8s 3S_1$ state to the $7s7p 3P_2$ state, from which there is no allowed transition path to the $7s^2 1S_0$ atomic ground state.”

Some population would be trapped in $7s7p 3P_2$.
Do we have an opportunity to observe a shift by the C constant?

How the experiment and the analysis would work

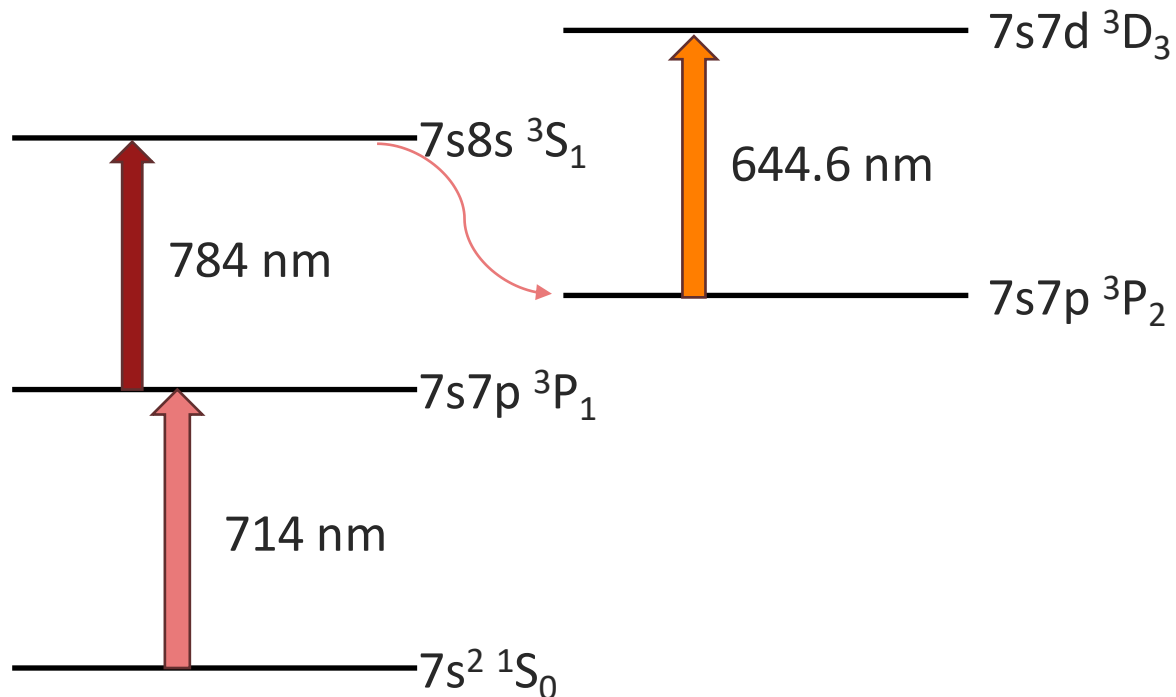
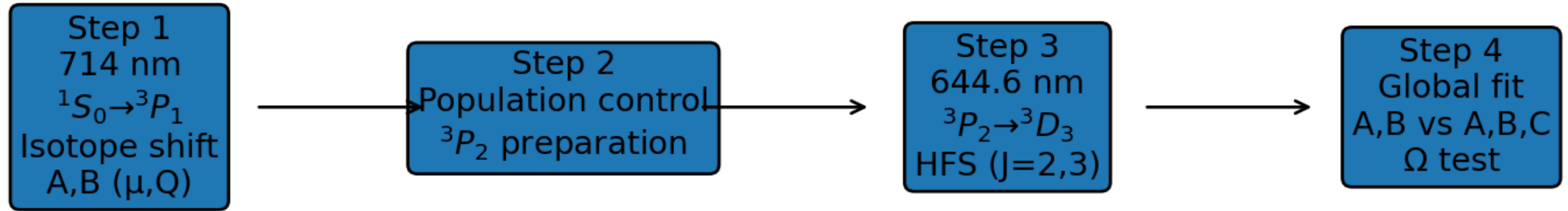

Compare two models:

Model 1: A, B

Model 2: A, B, C

Ask whether allowing C significantly improves global consistency

A staged program

Stage 1

Robust isotope shifts
and A/B measurements

Stage 2

Prepare and characterize
the 3P_2 state

Stage 3

Ω -sensitive
multi-state spectroscopy

Why ARIEL?

This kind of work needs:

beam availability

flexibility

time for systematic preparation

ideally a dedicated spectroscopy environment

That is why ARIEL is so attractive for this program

Not only a Ra idea

A possible direction for next-generation
laser spectroscopy of heavy exotic
nuclei

Take-home message

Radium is one of the best places to study octupole deformation

We know octupole correlations are strong

What we still do not know directly is whether the ground state is statically reflection-asymmetric

Multi-state CLS may provide a route through the rank-3 hyperfine interaction and Ω

I see this as a staged long-term program

Acknowledgement

Jens Lassen, thank you for the discussion about this rough idea

Audience, I would appreciate if you make a comment if this idea could be a possible proposal for ARIEL