

Status of HyperK-Canada group

Matej Pavin,
on behalf of the HyperK-Canada group

ACOT particle physics parallel session
November 15, 2019

EMPHAT!C

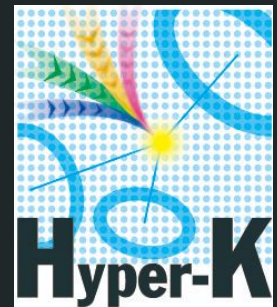

Introduction

- **Hyper Kamiokande is included in the new MEXT budget**
- **Submitted for approval to the Japanese Ministry of finance (to be decided in December)**
- HyperK measurements will be limited by systematics
- To reduce the systematics, HyperK-Canada group is working on:
 - Development of a new photosensor for Intermediate Water Cherenkov Detector (IWCD) and HyperK,
 - Water Cherenkov beam test for measuring the response of the Water Cherenkov detector,
 - Improved reconstruction and PID techniques for WC detectors based on machine learning,
 - Hadron production measurements for reducing the neutrino flux uncertainty (EMPHATIC experiment)
- **31 new students started this year:**

Graduate students:

- Six students (UVIC, Regina, Winnipeg)
- Three international internship students (France, Scotland, India) → 5 months - 1 year period

Undergraduate students:

- Six coop students
- Six UBC Capstone students
- Nine BCIT thesis students
- One highschool student

mPMT Development

- Based on KM3NeT design
 - 19 8 cm PMTs
 - Optimized for water Cherenkov detectors
- **First mechanical prototype at TRIUMF**
- Working on the design optimization and mass production
 - Ongoing discussion with several companies for the PMT matrix mass Production (injection molding, thermoforming, casting, 3D printing)
 - Developing optical gelling procedure (the slowest part of the assembly)
- Test stand for optical tests is being constructed at TRIUMF
- **\$5.4M CFI proposal will be submitted from University of Victoria for the construction of the half of mPMT's for IWCD**

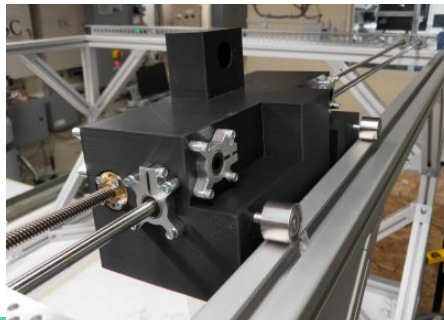
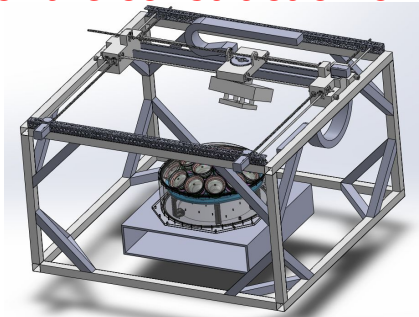
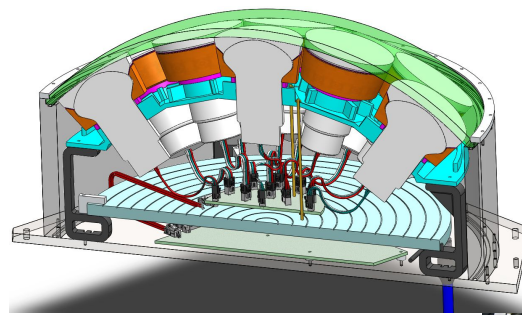

Water Cherenkov Beam Test

- Measuring the response of Water Cherenkov detector in a test beam at CERN → planned for 2021/22
- First meeting at CERN (July 18-19 2019)
 - Interest from broader community (THEIA and ESSnuSB)
 - Beam options: North Area and East Area
- LOI submitted in October [CERN-SPSC-2019-042](#)
- Full SPSC proposal to be finished in 1-2 months
 - The effort is led by M. Hartz (TRIUMF)

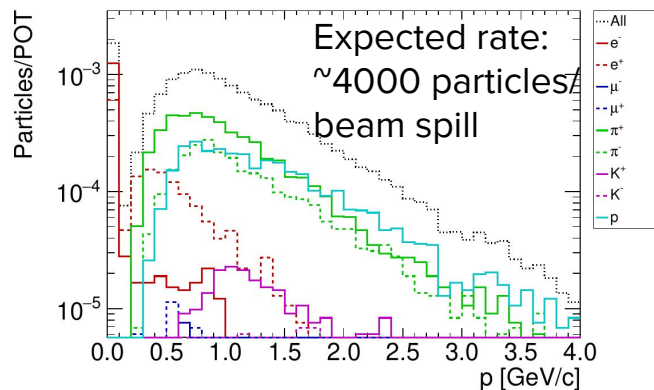
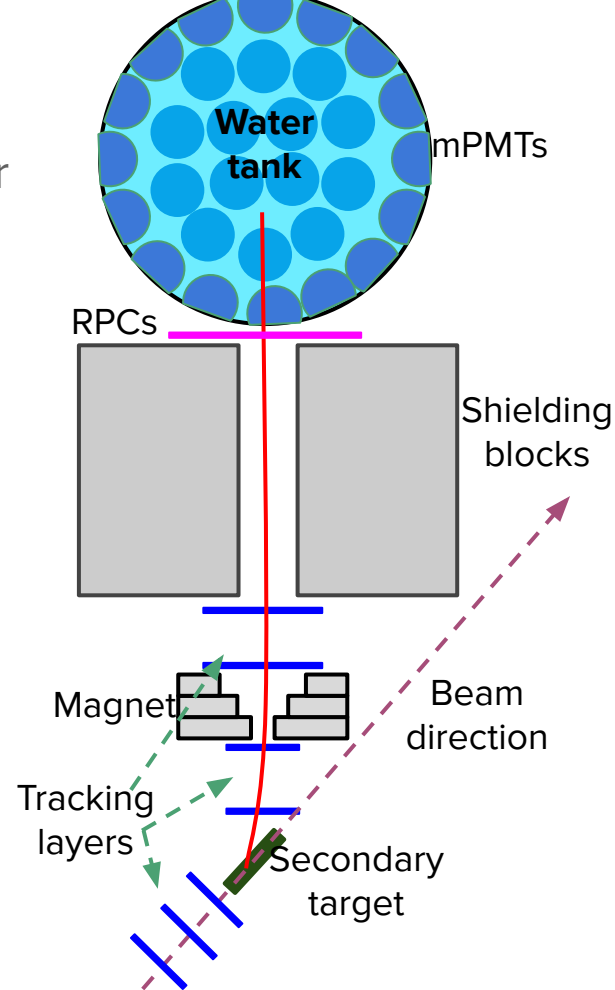

Machine Learning



WatChMaL.org

- Machine learning workshop at UVIC → formation of **Water Cherenkov Machine Learning (WatChMal)** group
 - In cooperation with Wojtek Fedorko (data scientist at TRIUMF)
- Using machine learning for PID and event reconstruction
- Convolutional Neural Networks (CNNs) for PID
 - **e- γ separation → impossible with traditional methods**
 - Preliminary study with CNNs → **73% γ rejection for 80% e signal efficiency**
- Variational autoencoders → generative models based on data → no model dependence systematics

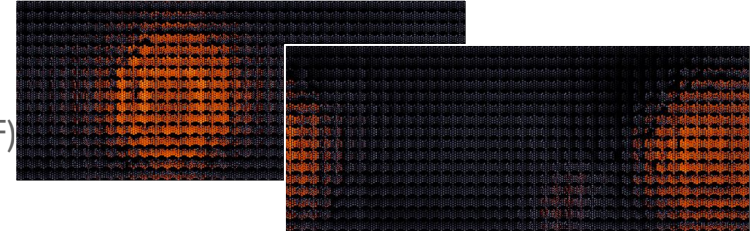

Randomly generated new events

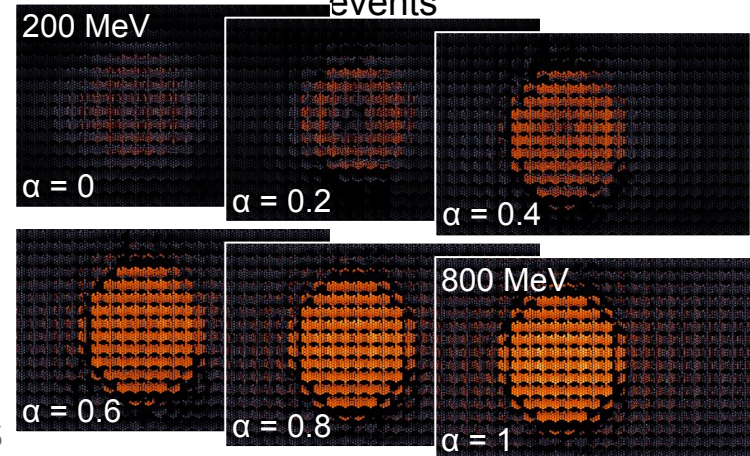

A leading author is Abhishek Abhishek, a coop student from Manitoba

→ [arXiv:1911.02369](https://arxiv.org/abs/1911.02369) [physics.ins-det]

EMPHATIC

(Experiment to Measure the Production of Hadrons At a Testbeam in Chicagoland)

- **Approved by Fermilab PAC**

- Preliminary results from the test run in 2018 were presented in Fermilab JETP seminar

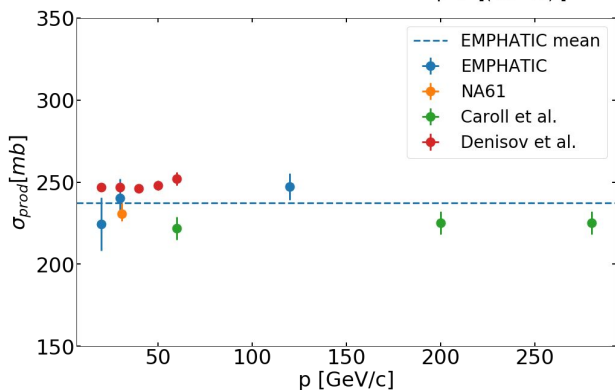
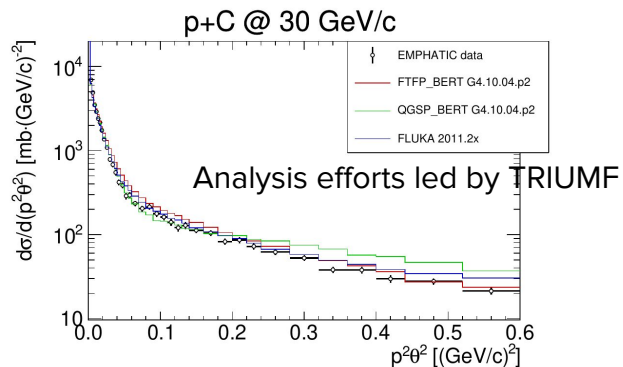

- **Next run April 1-20 2020**

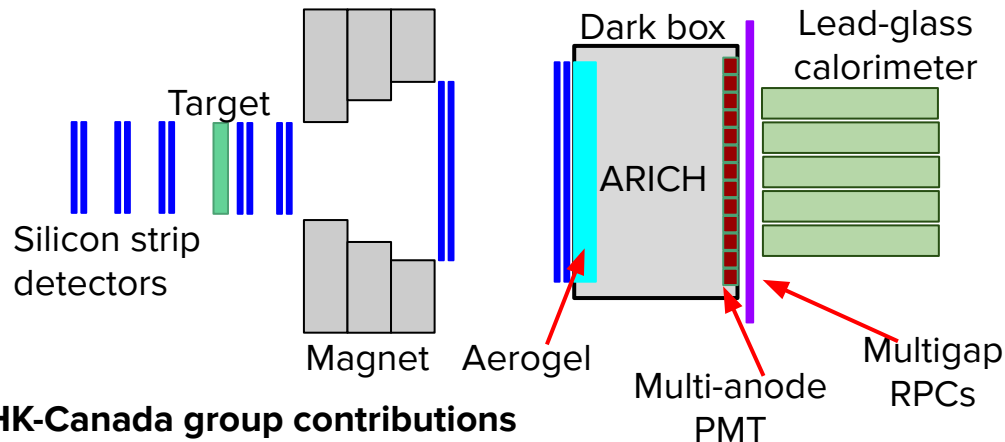

HK-Canada group contributions

- Small permanent magnet (150 mrad)
- ARICH v1 (prototype currently being tested at TRIUMF)
- DAQ software, reconstruction, calibration and MC simulation

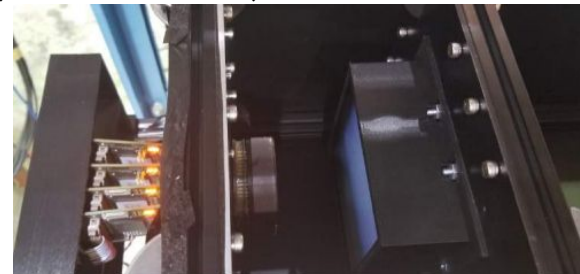
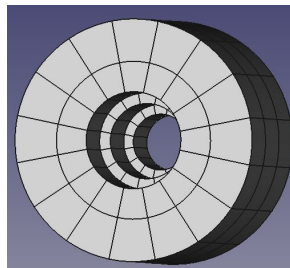

Summary

The Japanese ministry of Education has included Hyper Kamiokande (HyperK) project in the proposed budget for the fiscal year 2020. The budget was submitted for approval to the Japanese Ministry of finance. The HyperK-Canada group is working towards reducing systematic uncertainties in HyperK. A total of 31 undergraduate and graduate students started working in the group this year.

A first mechanical prototype of the multi-PMT (mPMT) module has been built at TRIUMF, and the full prototype will be ready by the end of the year. The group is working towards the development of the mass production procedure. We are submitting a CFI proposal (5.4 mil. \$) from the University of Victoria for the construction of the half of mPMT's for IWCD.

We plan to measure the response of the small Water Cherenkov (WC) detector with mPMTs in a beam test at CERN. The letter of intent was submitted to CERN in October, and the full SPSC proposal will be ready by the end of the year.

The HyperK-Canada group is working on new reconstruction and particle identification algorithms in WC detectors based on machine learning. Initial studies show the possibility of using convolutional neural networks for electron-gama separation and for building generative models based on data. An undergraduate student has submitted a paper with the results of the initial study.

The Fermilab PAC has recently approved EMPHATIC experiment. The first results from the 2018 run were presented at the Fermilab JETP seminar, and the TRIUMF group is leading the analysis efforts. The next data-taking period is scheduled for April 2020. The HyperK Canada contributions include a magnet, aerogel RICH detector, DAQ reconstruction, and MC simulation.