

# Noble Liquid Detectors



Michela Lai, Queen's University  
GRIDS 2026



Arthur B. McDonald  
Canadian Astroparticle Physics Research Institute



Queen's  
UNIVERSITY

# Content

- Properties of noble liquids
- Processes in noble liquids that we could use
- Some math
- Detectors



# Noble Gases

- Discovered by William Ramsay Scottish chemist and professor at UC London
  - Won 1904 Nobel Prize in Chemistry
  - Started university in Glasgow at 14
  - Got a google doodle on 167th birthday
- Also gave them fun names!

Argon - Greek for “lazy”

Neon - Greek for “new”

Krypton -Greek for “hidden”

Xenon - Greek for “stranger”

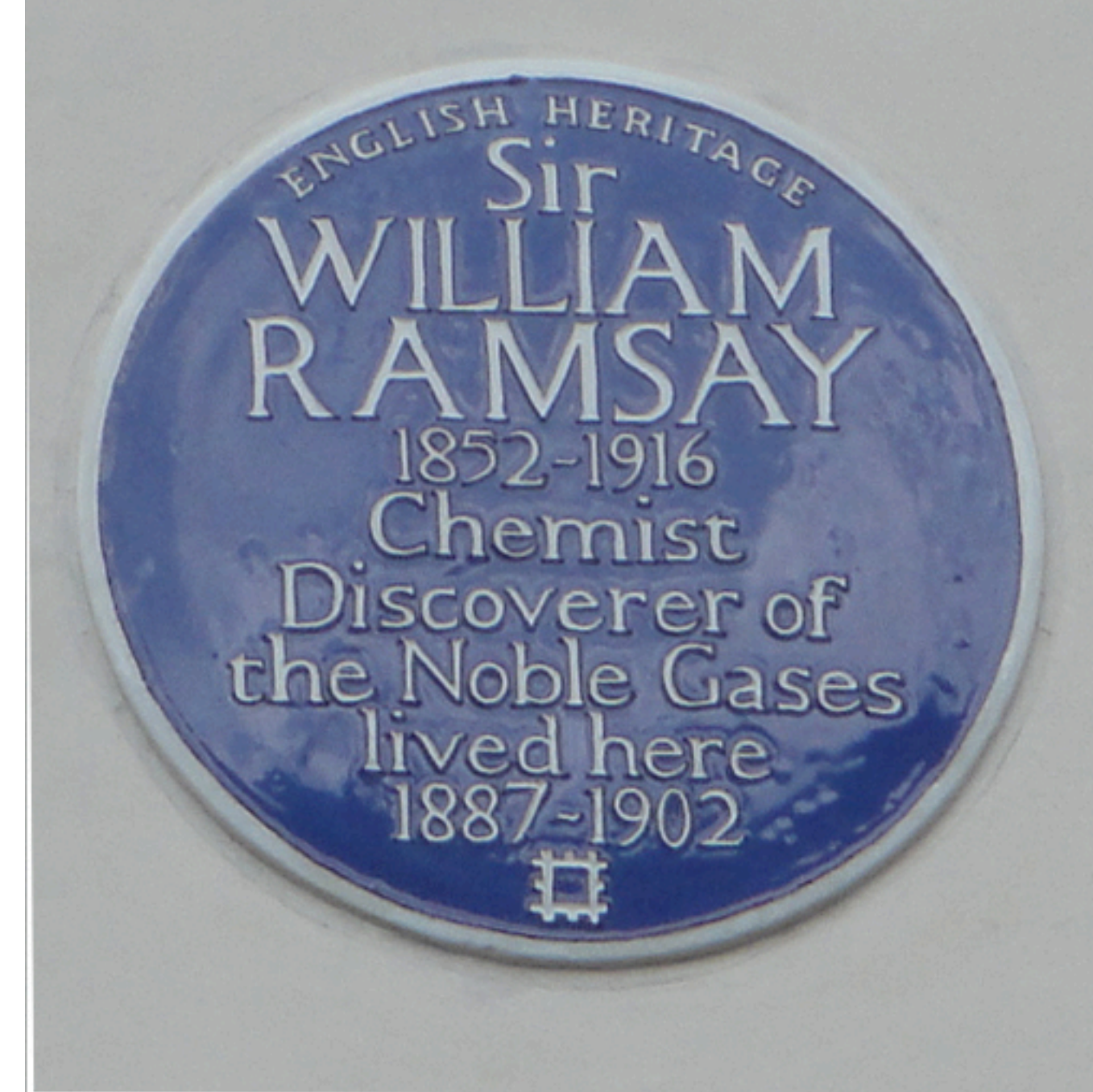

Credit: Wikipedia



# Noble Gases

- The scarcity of the gases in air is the real difficulty here

W. Ramsay: "These gases occur in the air but sparingly as a rule, for while argon forms nearly 1 hundredth of the volume of the air, neon occurs only as 1 to 2 hundred-thousandth, helium as 1 to 2 millionth, krypton as 1 millionth and xenon only as about 1 twenty-millionth part per volume. This more than anything else will enable us to form an idea of the vast difficulties which attend these investigations"

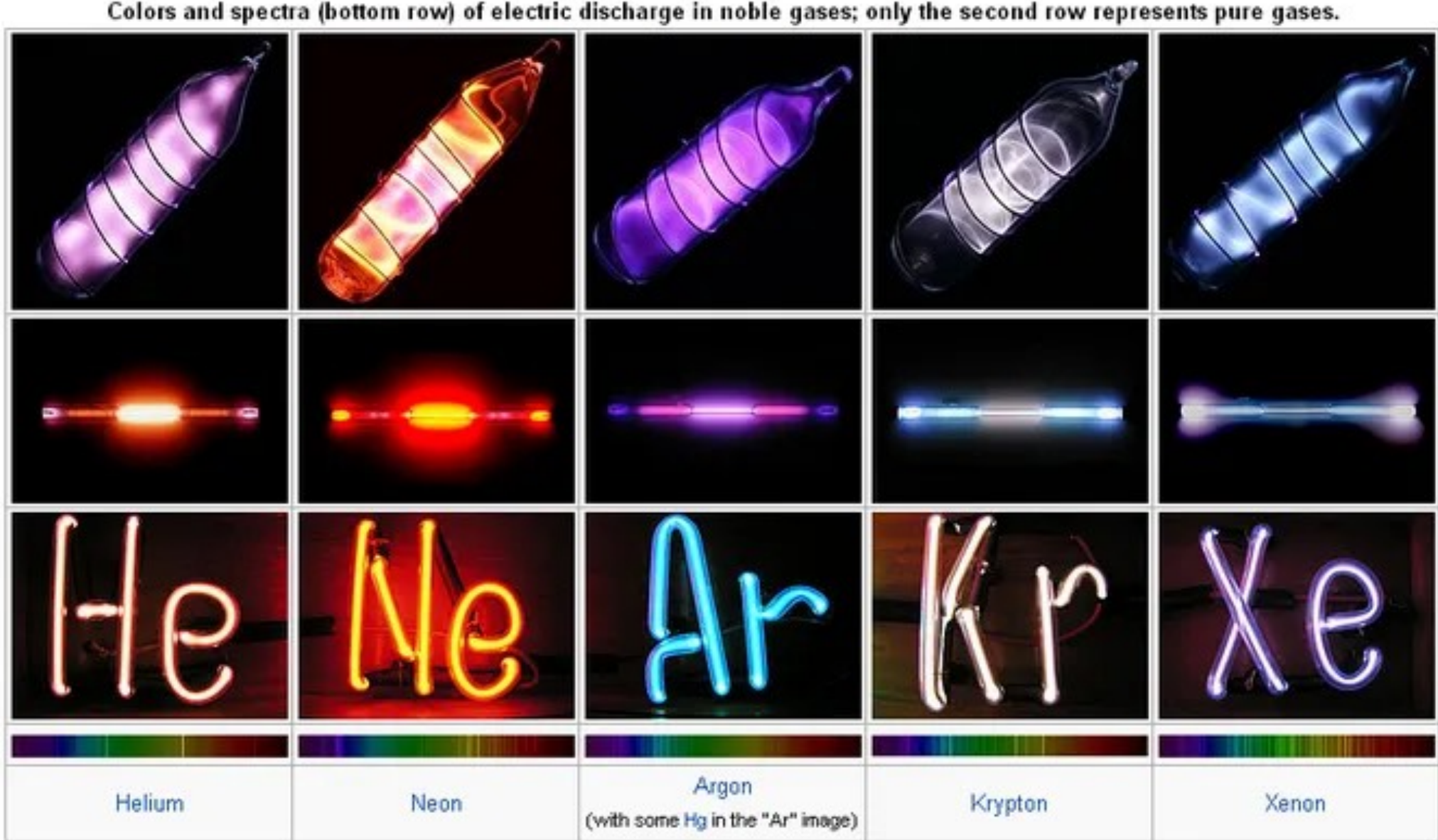
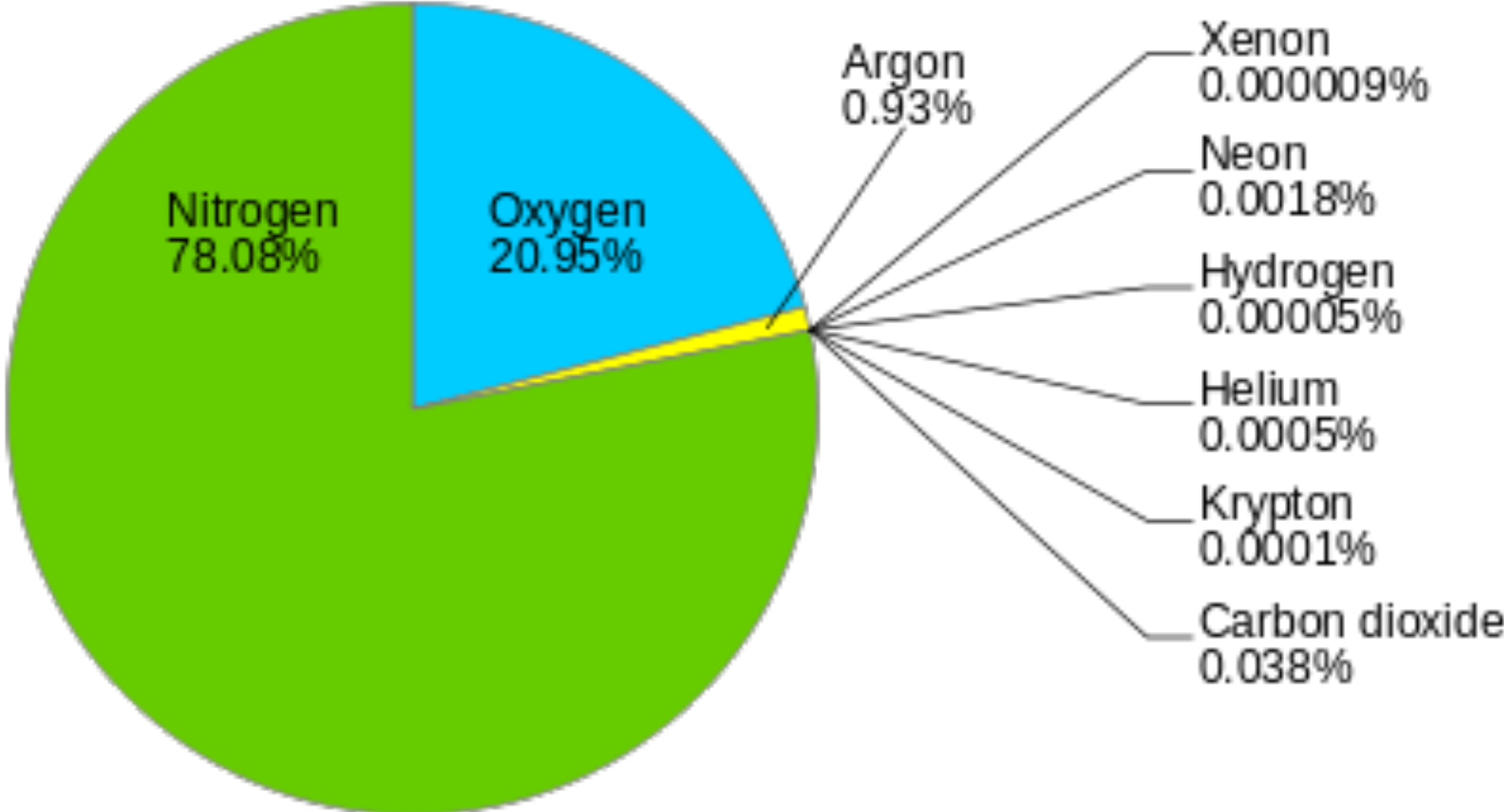

# Properties

- An increasing number of rare event detectors are using noble elements as the target
- So.... why is this?
  1. Density
  2. Inertness
  3. Ionization
  4. Scintillation

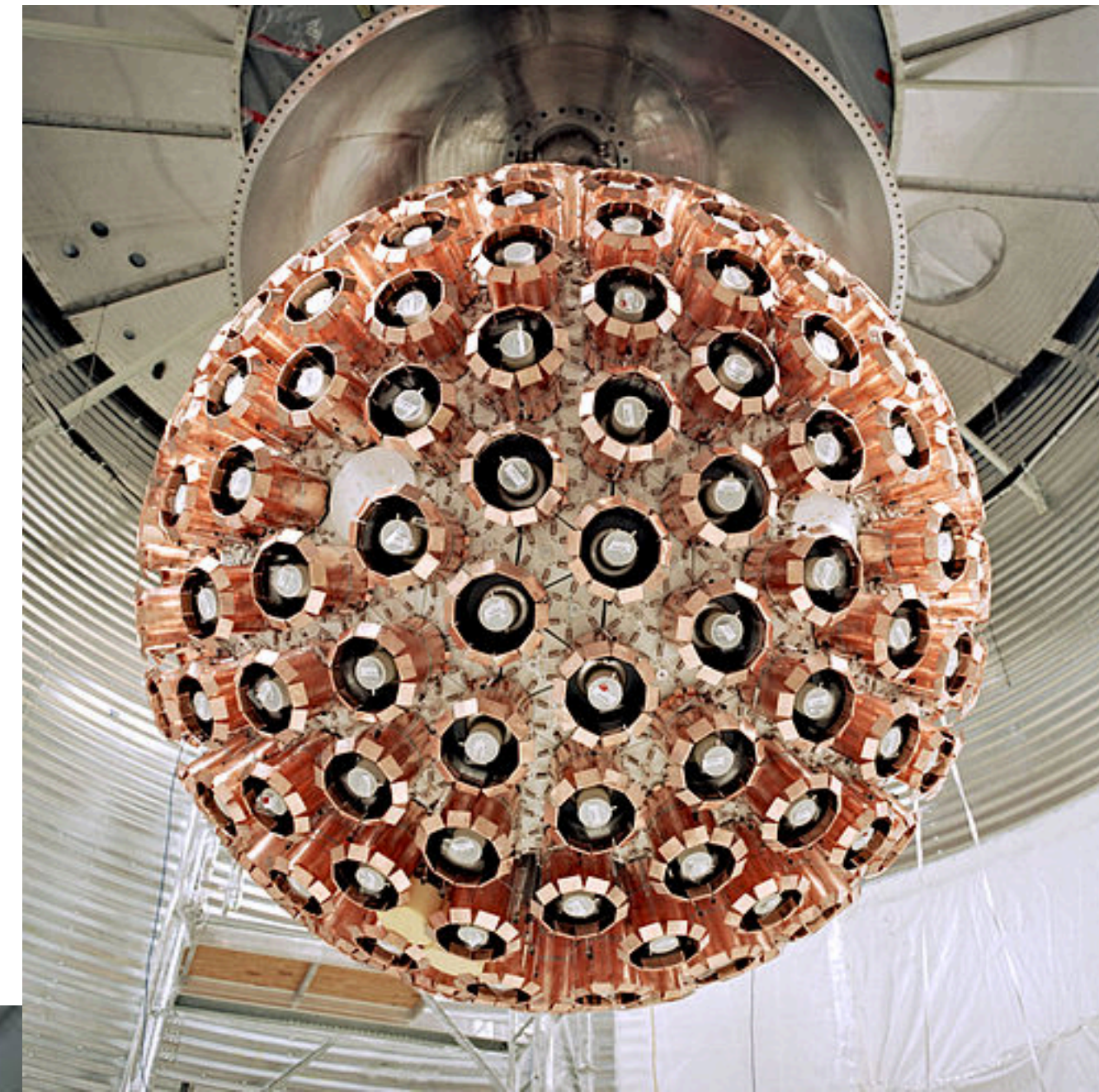

# Properties - Density (and others)

- Comparing some of the physical properties

Element	Z (A)	Melting Point at 1atm [K]	Boiling Point at 1atm [K]	Liquid Density at $T_b$ [g/cc]	Dielectric constant	Ionization [e-/keV]	Scintillation [photon/keV]
He	2 (4)	0.95	4.2	0.13	1.06	39	15
Ne	10 (20)	24.6	27.1	1.21	1.53	46	7
Ar	18 (40)	83.8	87.3	1.40	1.51	42	40
Kr	36 (84)	115.8	119.8	2.41	1.66	49	25
Xe	54 (131)	161.4	165	2.95	1.95	64	46

# Noble elements

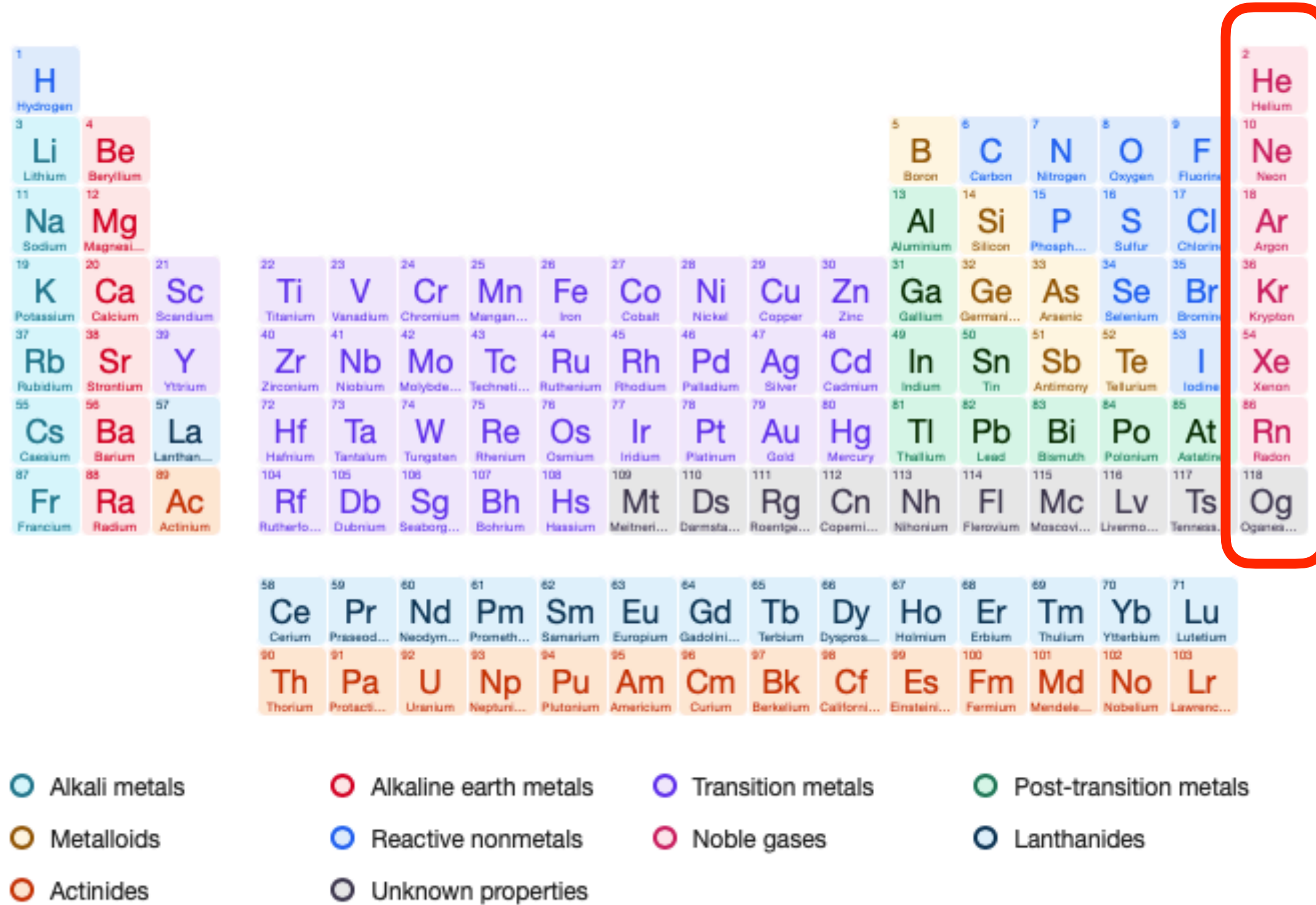

- But wait, I missed one, or maybe two?
  - Yeah, sort of
- I'll only be talking about elements that can be used in low-background detectors, ruling out those that are radioactive (Rn and Oganesson) and especially those with short half-lives (Og is ~1 second)

# Noble elements

Can I lick it?

Period	Group 1*	2	3	4	5	6	7	8	9	10	11	12	13	14	15	16	17	18
1	H																	He
2	Li	Be											B	C	N	O	F	Ne
3	Na	Mg											Al	Si	P	S	Cl	Ar
4	K	Ca	Sc	Ti	V	Cr	Mn	Fe	Co	Ni	Cu	Zn	Ga	Ge	As	Se	Br	Kr
5	Rb	Sr	Y	Zr	Nb	Mo	Tc	Ru	Rh	Pd	Ag	Cd	In	Sn	Sb	Te	I	Xe
6	Cs	Ba	La	Hf	Ta	W	Re	Os	Ir	Pt	Au	Hg	Tl	Pb	Bi	Po	At	Rn
7	Fr	Ra	Ac	Rf	Db	Sg	Bh	Hs	Mt	Ds	Rg	Cn	Nh	Fl	Mc	Lv	Ts	Og
Lanthanoid series 6																		
Actinoid series 7																		

Legend:

- Green: Sure, go for it
- Yellow: Maybe not the best idea
- Red: Please don't do that
- Purple: See you on the other side

- But wait, I missed one, or maybe two?
  - Yeah, sort of
- I'll only be talking about elements that can be used in low-background detectors, ruling out those that are radioactive (Rn and Oganesson) and especially those with short half-lives (Og is ~1 second)

Mostly follow the “can I lick it” rules

# Properties - Density (and others)

- Comparing some of the physical properties

Element	Z (A)	Melting Point at 1atm [K]	Boiling Point at 1atm [K]	Liquid Density at $T_b$ [g/cc]	Dielectric constant	Ionization [e-/keV]	Scintillation [photon/keV]
He	2 (4)	0.95	4.2	0.13	1.06	39	15
Ne	10 (20)	24.6	27.1	1.21	1.53	46	7
Ar	18 (40)	83.8	87.3	1.40	1.51	42	40
Kr	36 (84)	115.8	119.8	2.41	1.66	49	25
Xe	54 (131)	161.4	165	2.95	1.95	64	46



# Properties - Density (and others)

- Comparing some of the physical properties

Element	Z (A)	Melting Point at 1atm [K]	Boiling Point at 1atm [K]	Liquid Density at T <sub>b</sub> [g/cc]	Dielectric constant	Ionization [e-/keV]	Scintillation [photon/keV]
He				0.13	1.06	39	15
Ne				1.21	1.53	46	7
Ar				1.40	1.51	42	40
Kr				2.41	1.66	49	25
Xe				2.95	1.95	64	46

Higher density has advantages

- Higher stopping power
- Better fiducialization
- Large masses easier to achieve
- Self shielding

# Properties - Liquid Temperatures

- Comparing some of the physical properties

Element	Z (A)	Melting Point at 1atm [K]	Boiling Point at 1atm [K]	Liquid Density at $T_b$ [g/cc]	Dielectric constant	Ionization [e-/keV]	Scintillation [photon/keV]
He	2 (4)	0.95	4.2	0.13	1.06	39	15
Ne	10 (20)	24.6	27.1	1.21	1.51	42	7
Ar	18 (40)	83.8	87.3	1.40	1.66	49	40
Kr	36 (84)	115.8	119.8	2.41	1.95	64	25
Xe	54 (131)	161.4	165	2.95			46

This can be a bit tricky though...

# Properties - Density (and others)

- Comparing some of the physical properties

Element	Z (A)	Melting Point at 1atm [K]	Boiling Point at 1atm [K]	Liquid Density at $T_b$ [g/cc]	Dielectric constant	Ionization [e-/keV]	Scintillation [photon/keV]
He	2 (4)	0.95	4.2	0.13	1.06	39	15
Ne	10 (20)	2	But rewarding!		1.53	46	7
Ar	18 (40)	83.8	87.3	1.40	1.51	42	40
Kr	36 (84)	115.8	119.8	2.41	1.66	49	25
Xe	54 (131)	161.4	165	2.95	1.95	64	46

# Particle Detection

- Most of what we want to do is detect particles, regardless of what they might be
- At the most fundamental level, this requires an interaction by the particle with the target that produces a measurable quantity
- Essentially there are three (perhaps four) noted on the dark matter detector chart

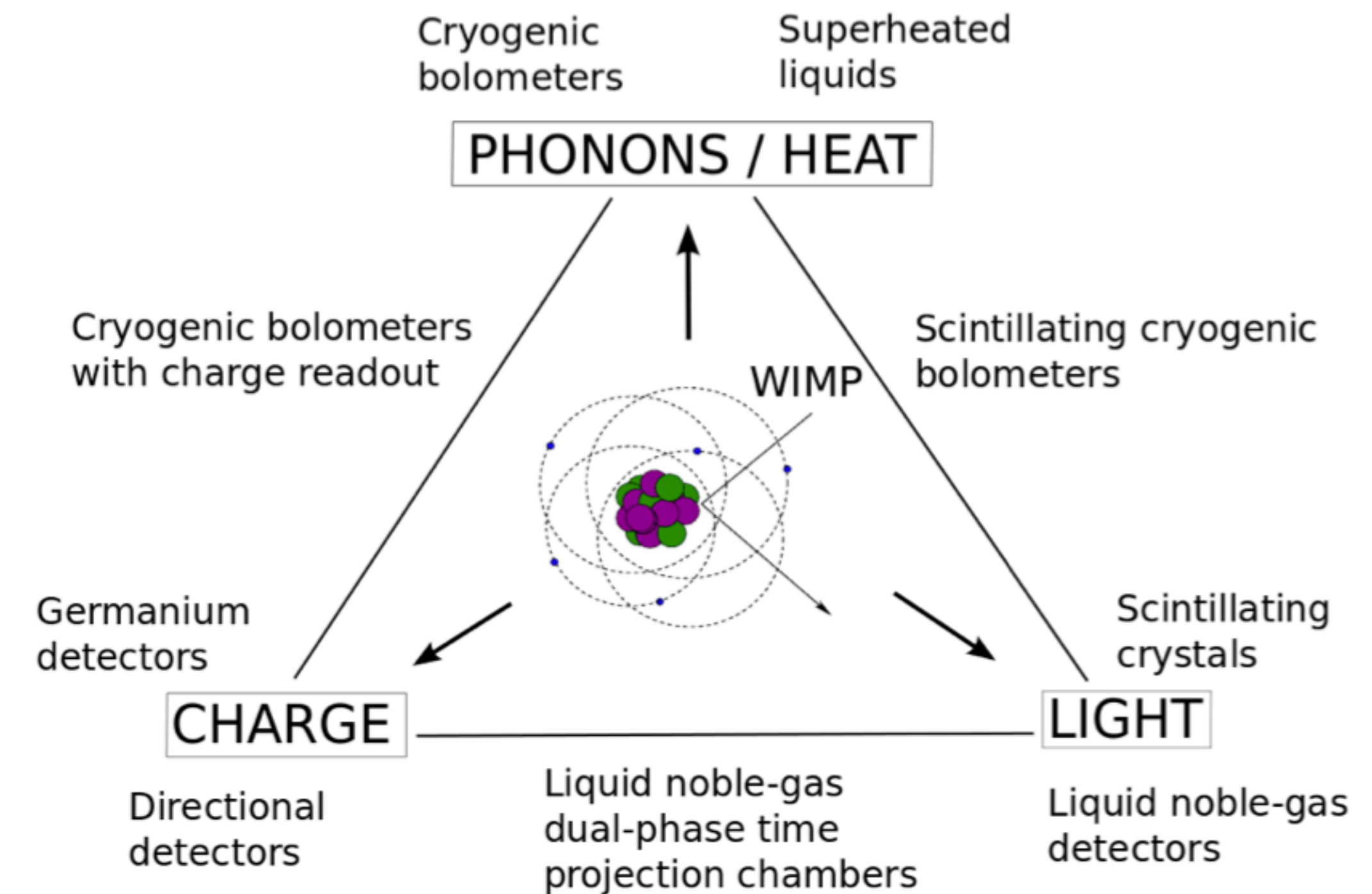

# Particle Detection

- Most of what we want to do is detect particles, regardless of what they might be
- At the most fundamental level, this requires an interaction by the particle with the target that produces a measurable quantity
- Essentially there are three (perhaps four) noted on the dark matter detector chart

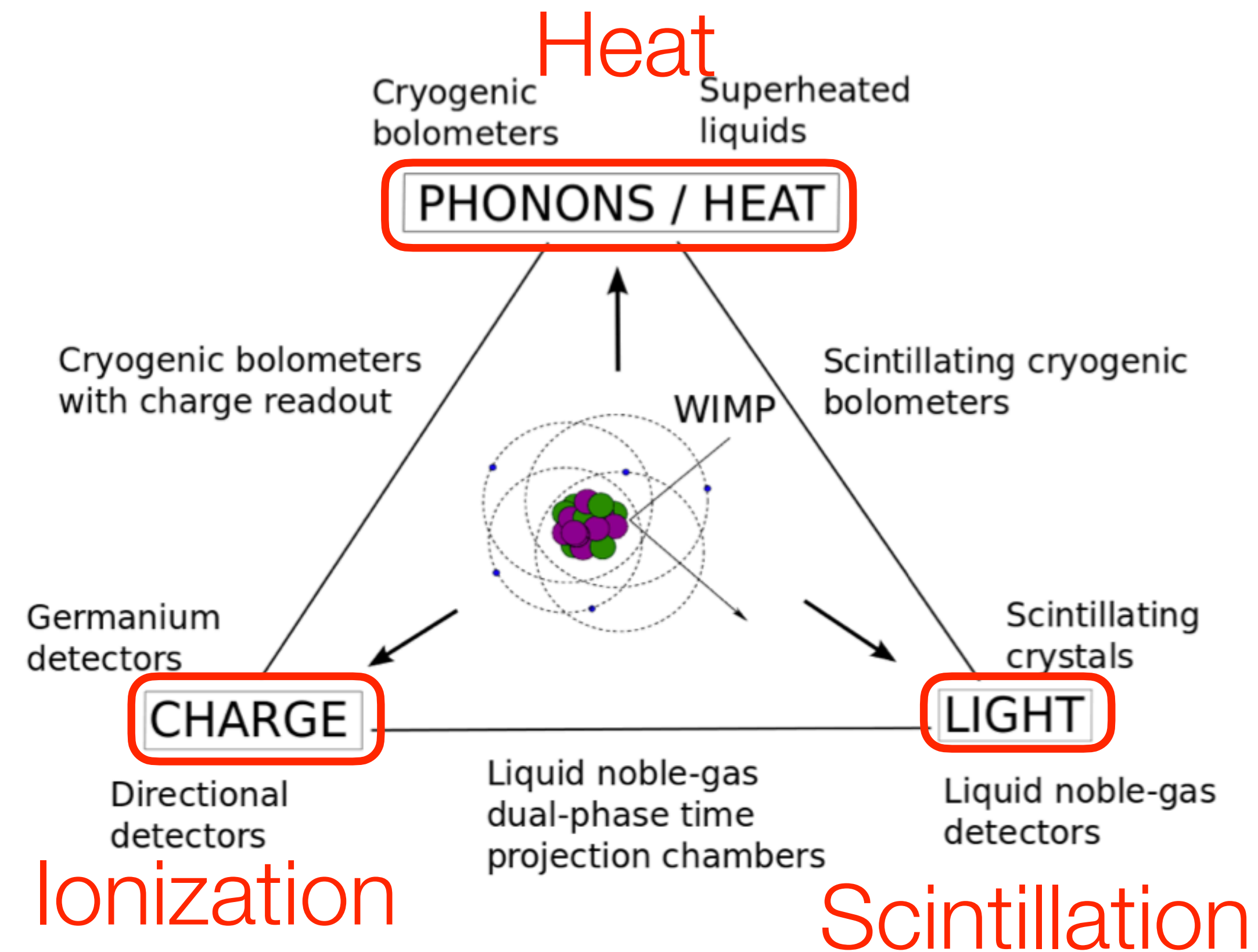

# Properties - Ionization

- Here we'll need to talk about the ionization energy — the energy required to remove an electron from a neutral atom
- Atomic structure means that the ionization energy generally increases across a row in the periodic table

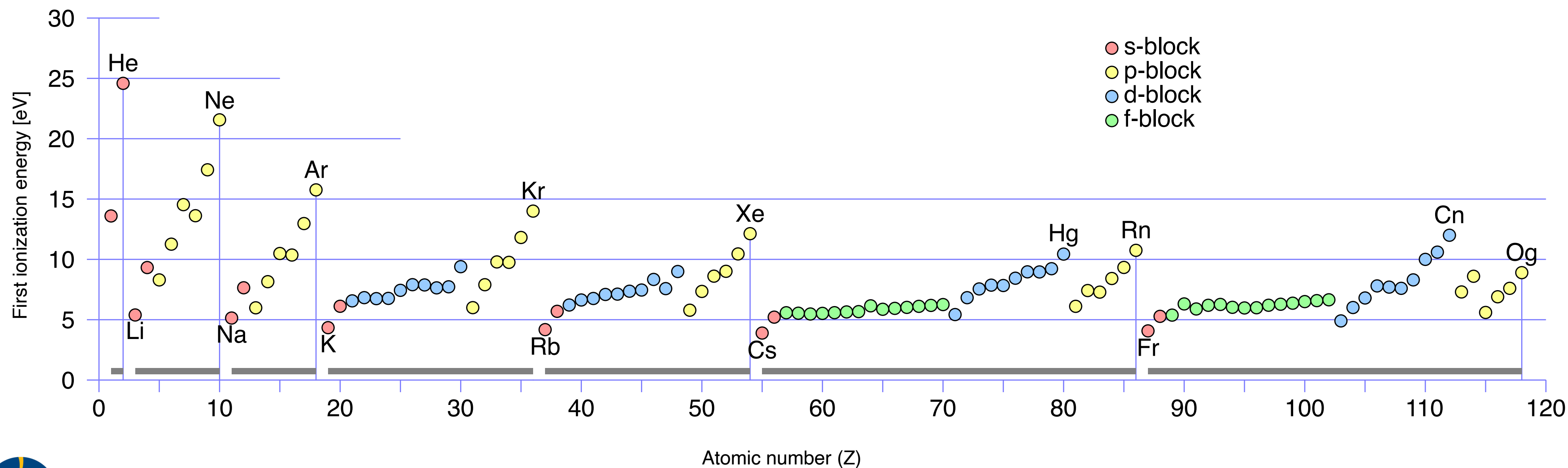
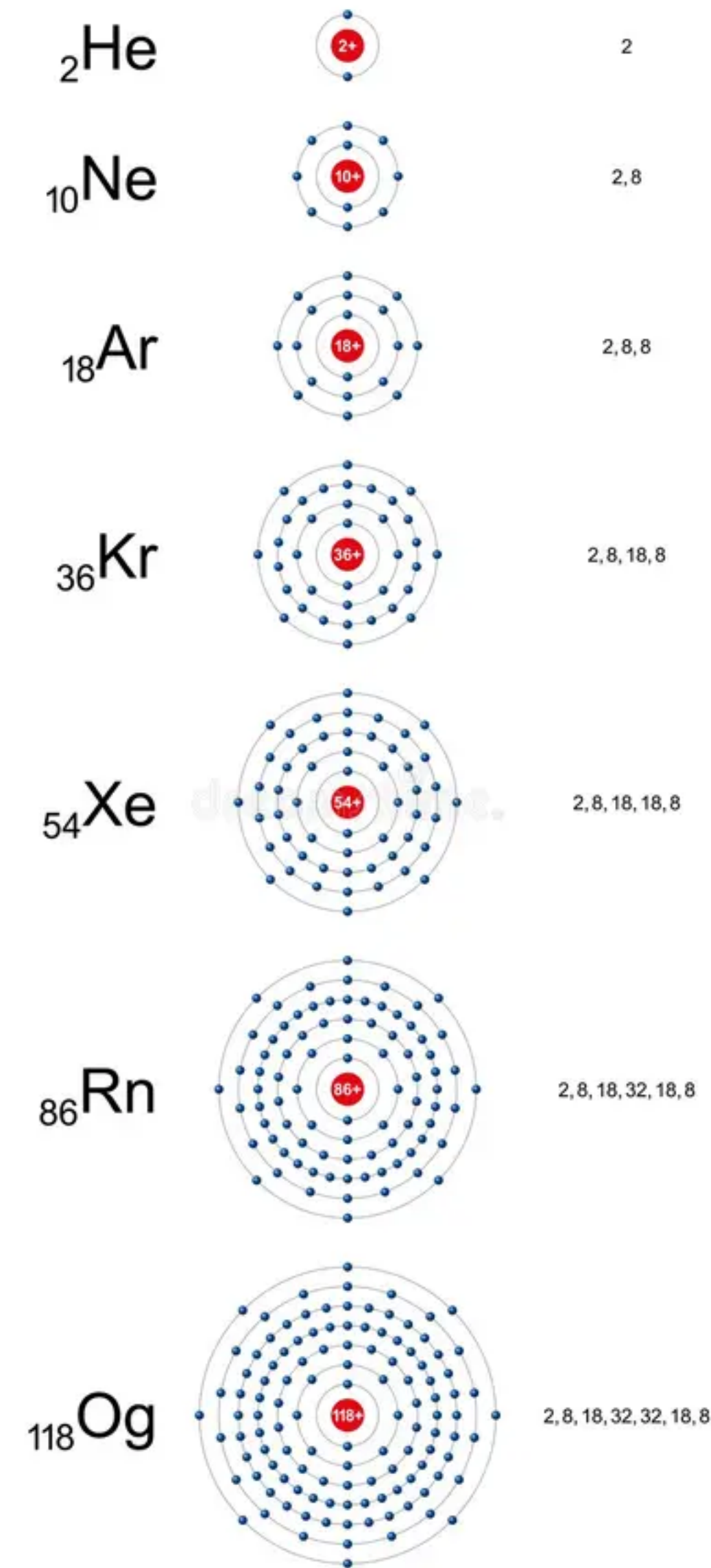

# Properties - Ionization

- Most concerned with the “W-value”, defined as the energy required to create an electron/ion pair
- It has also been said that in their liquid states, noble elements have a band-like structure of electronic states, so the gap energy is most important
- Notable that the average energy loss in ionization is a bit more than the ionization potential because it includes multiple ionization processes
- Generally 40-60% of absorbed energy is converted into free charge carriers

Element	Ar	Kr	Xe
Gas			
Ionization Potential (eV)	15.75	14.00	12.13
W-value (eV)	26.4	24.2	22
Liquid			
Gap energy (eV)	14.3	11.6	9.3
W-value (eV)	19.5±1.0	18.4±0.3	13.7±0.2

# Properties - Scintillation

- Light is produced in noble elements happens in two different ways
- The first way is “direct excitation”, though it’s not as direct as it sounds
- The second way is through ionization which we just talked about, but with some added fun



Credit: Medium



# Properties - Scintillation

1. Ionizing radiation produces an excited atom ( $R^*$ )

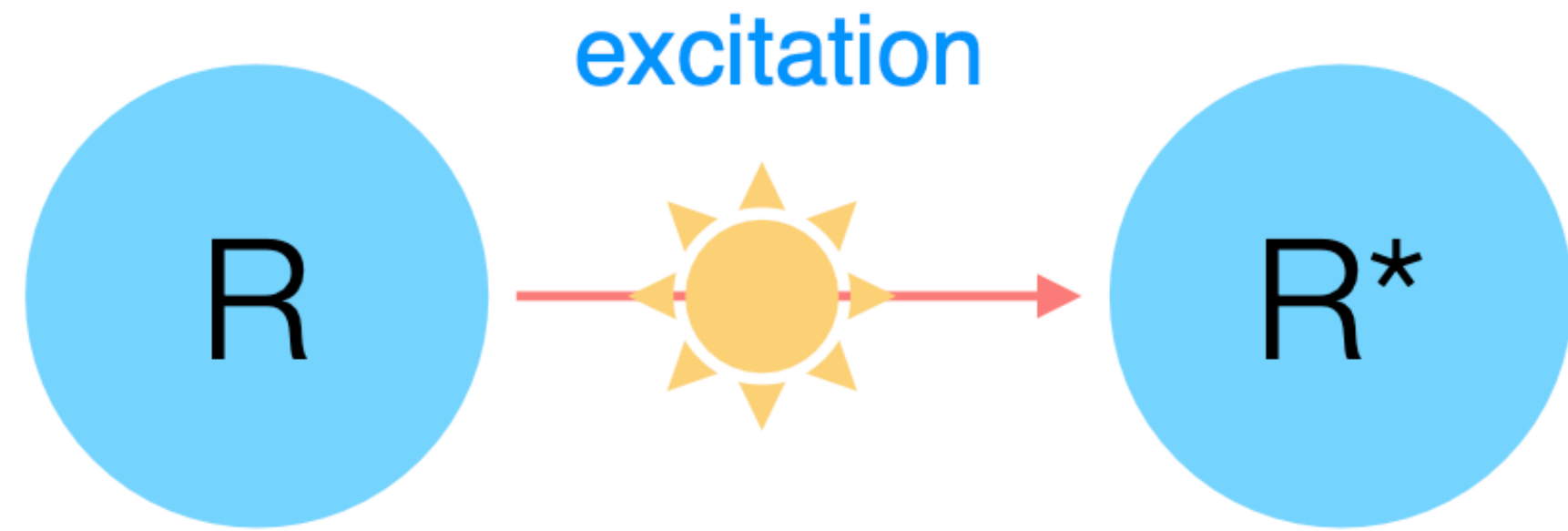

# Properties - Scintillation

1. Ionizing radiation produces an excited atom ( $R^*$ )
2. That excited atom finds another atom

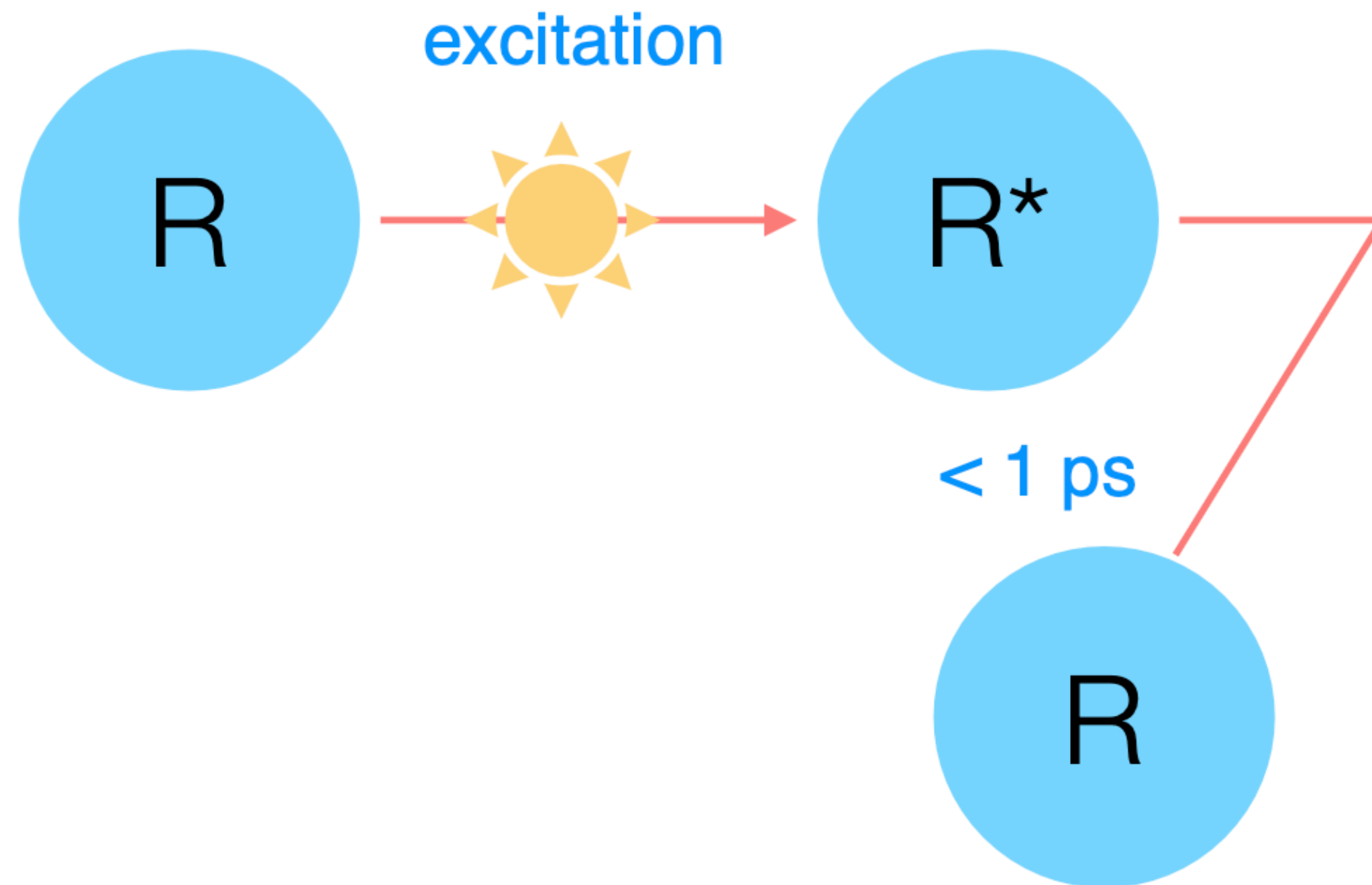

# Properties - Scintillation

1. Ionizing radiation produces an excited atom ( $R^*$ )
2. That excited atom finds another atom
3. They bond to form an excimer

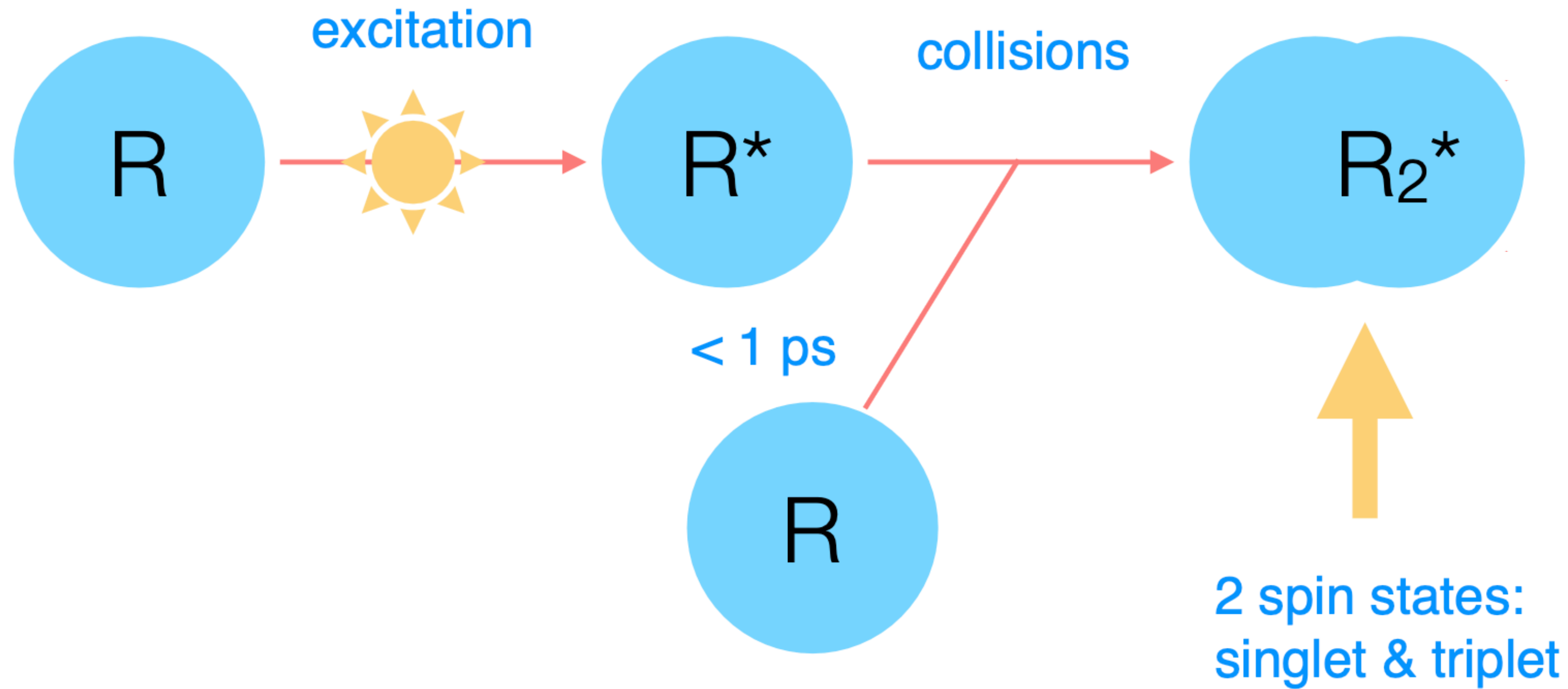

# Properties - Scintillation

1. Ionizing radiation produces an excited atom ( $R^*$ )
2. That excited atom finds another atom
3. They bond to form an excimer
4. That excimer de-excites to the ground state

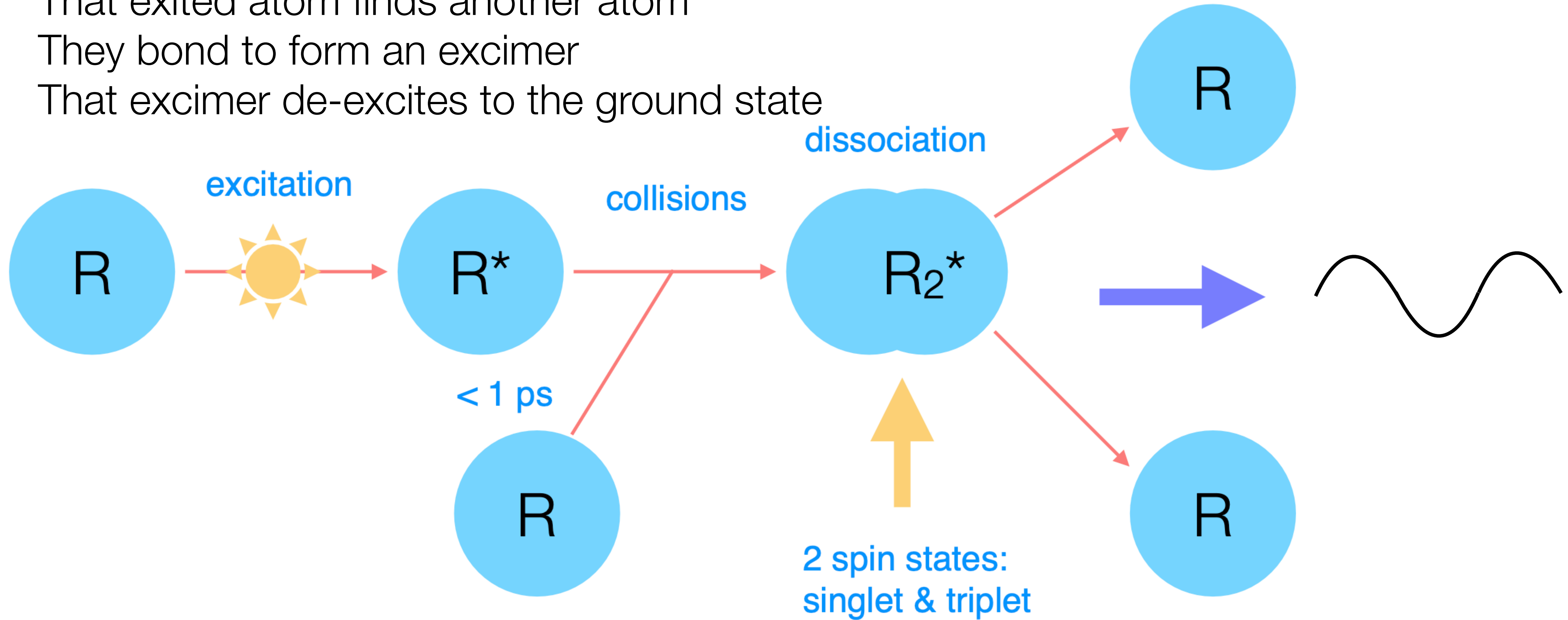

# Wait! Excimer?

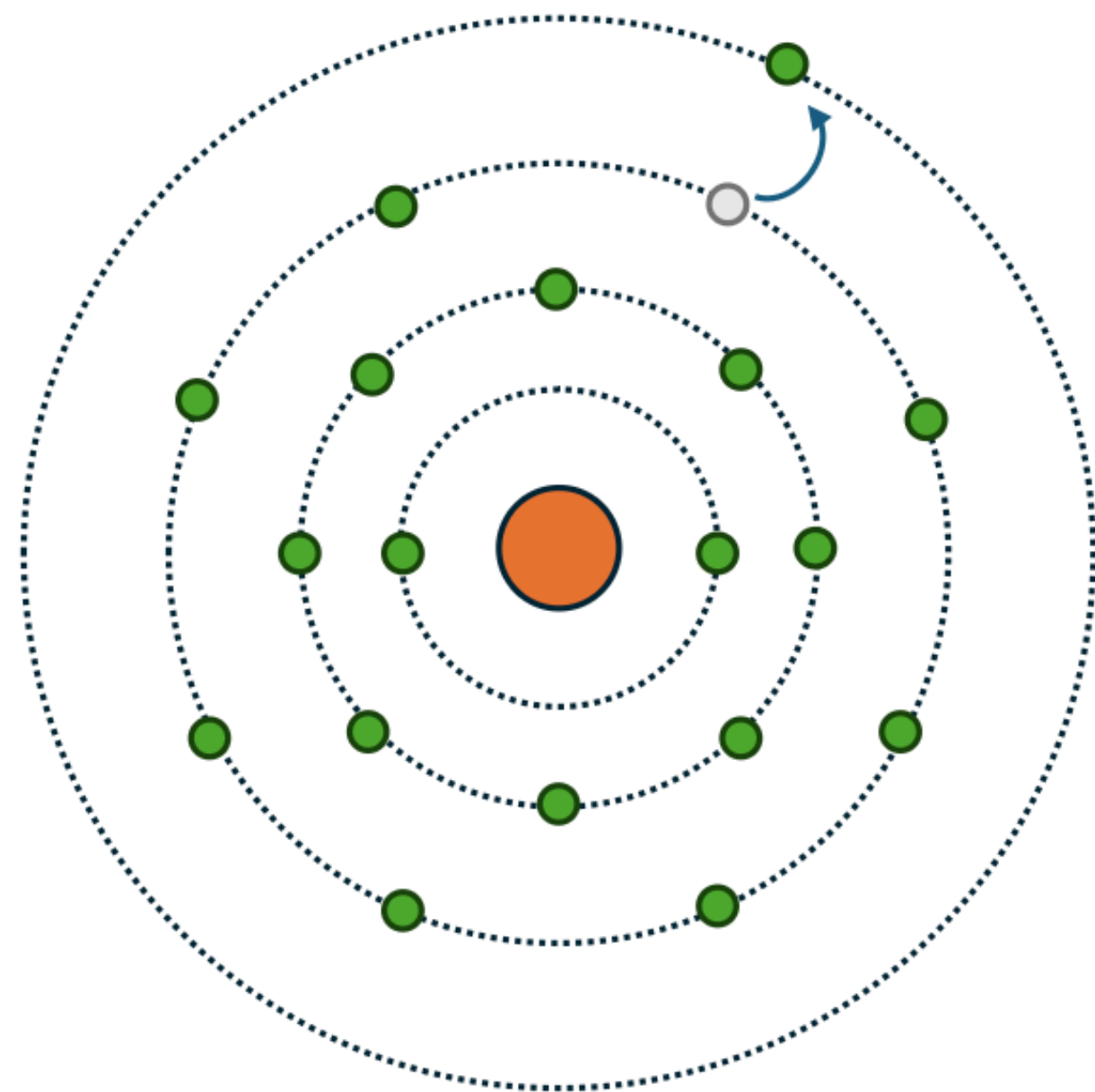

$\text{Ar}^*$

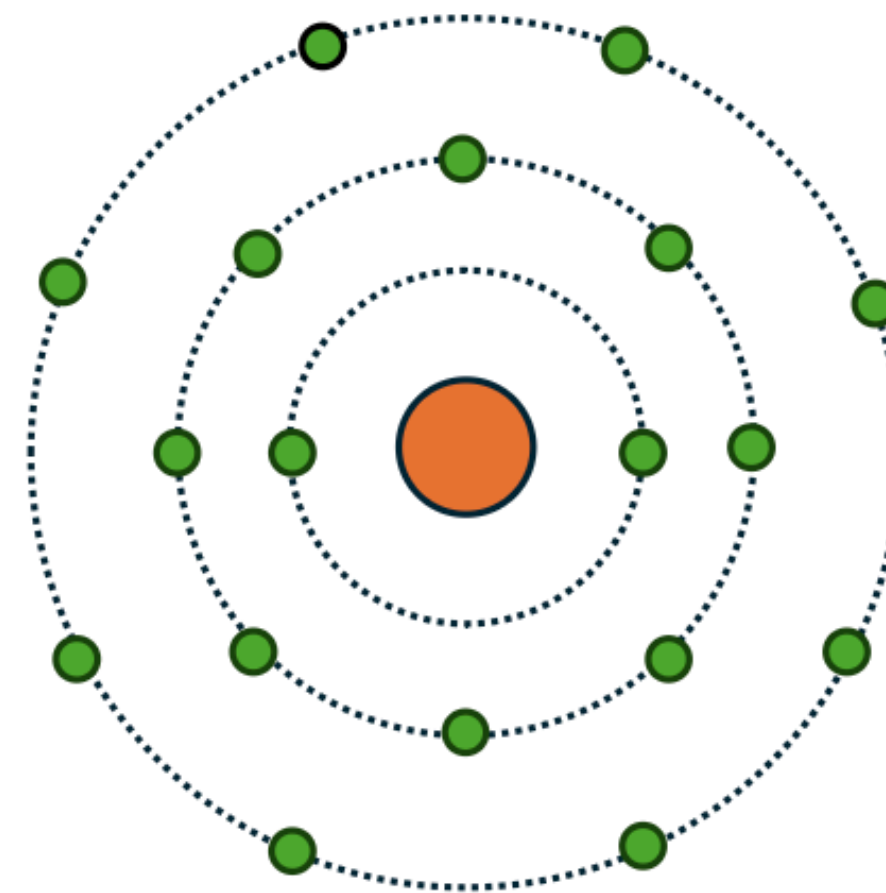

$\text{Ar}$

- What in the world is an excimer?
- It's kind of a molecule, though it requires one of the atoms to be in an excited state to make it happen



# Wait! Excimer?

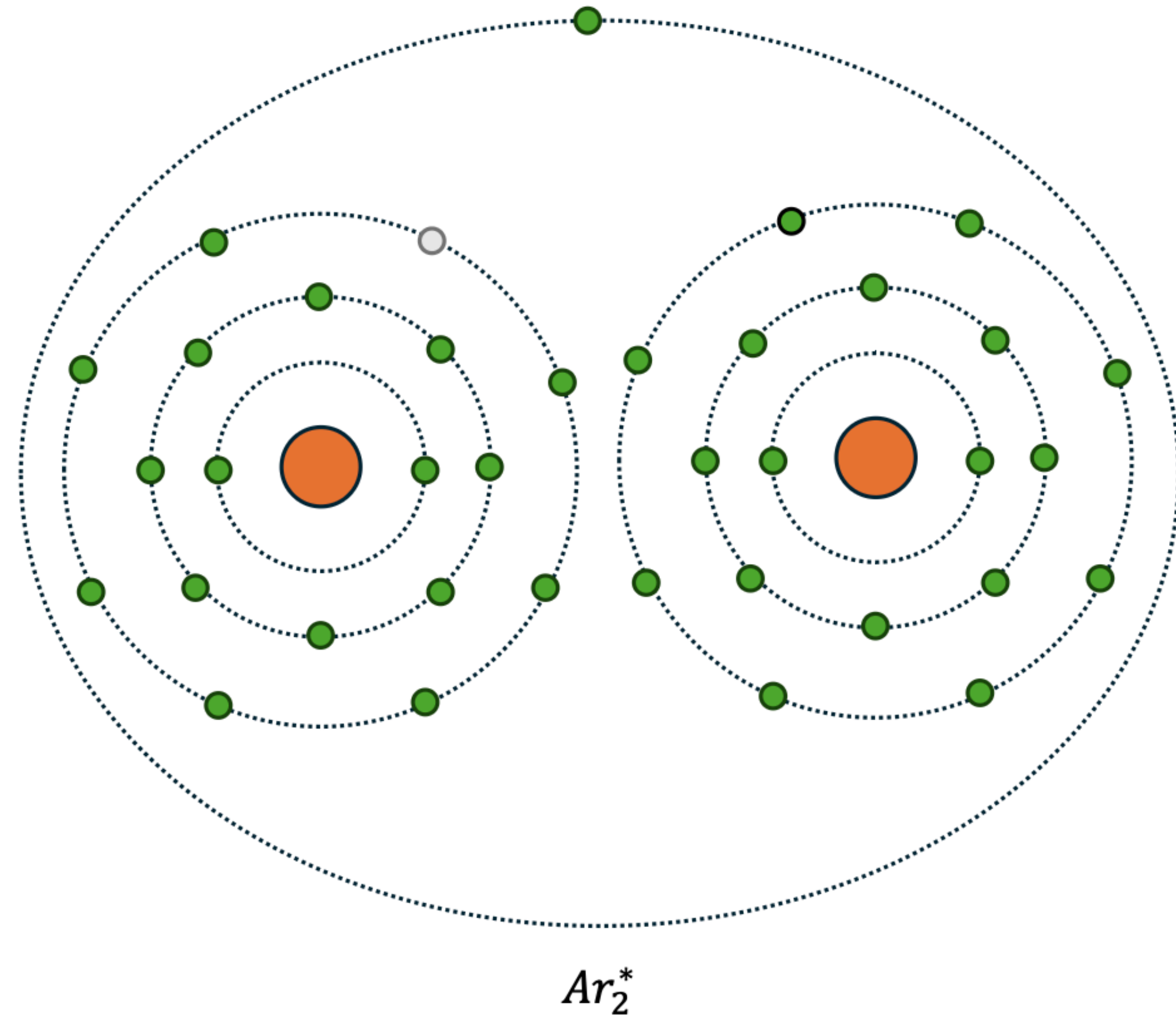

- What in the world is an excimer?
- It's kind of a molecule, though it requires one of the atoms to be in an excited state to make it happen



# Wait! Excimer?

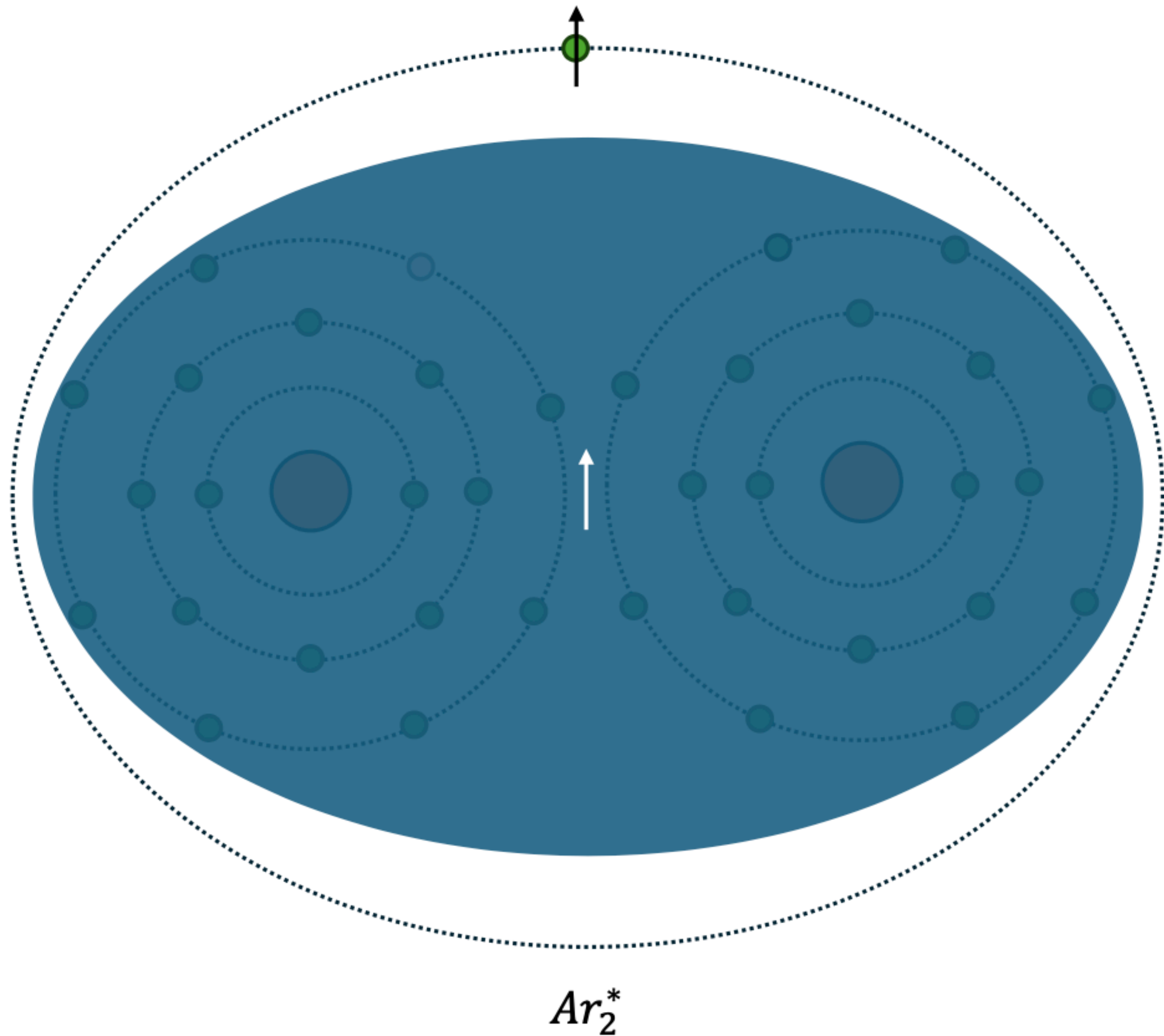

- The spin states of the excited electron and the remainder of the molecule are important here

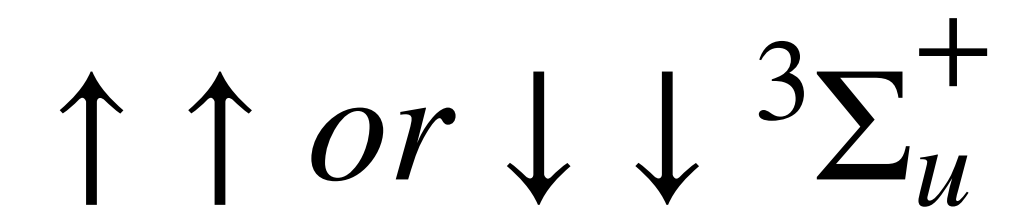
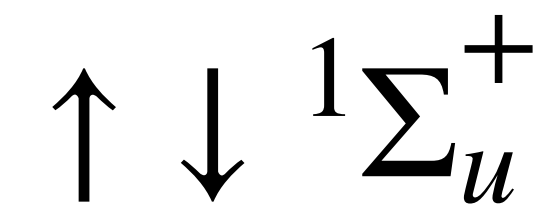

# Wait! Excimer?

- The timing is also set by the differences in these processes
- The allowed transit is fast (~ps) while the forbidden transition is slow (many ns)

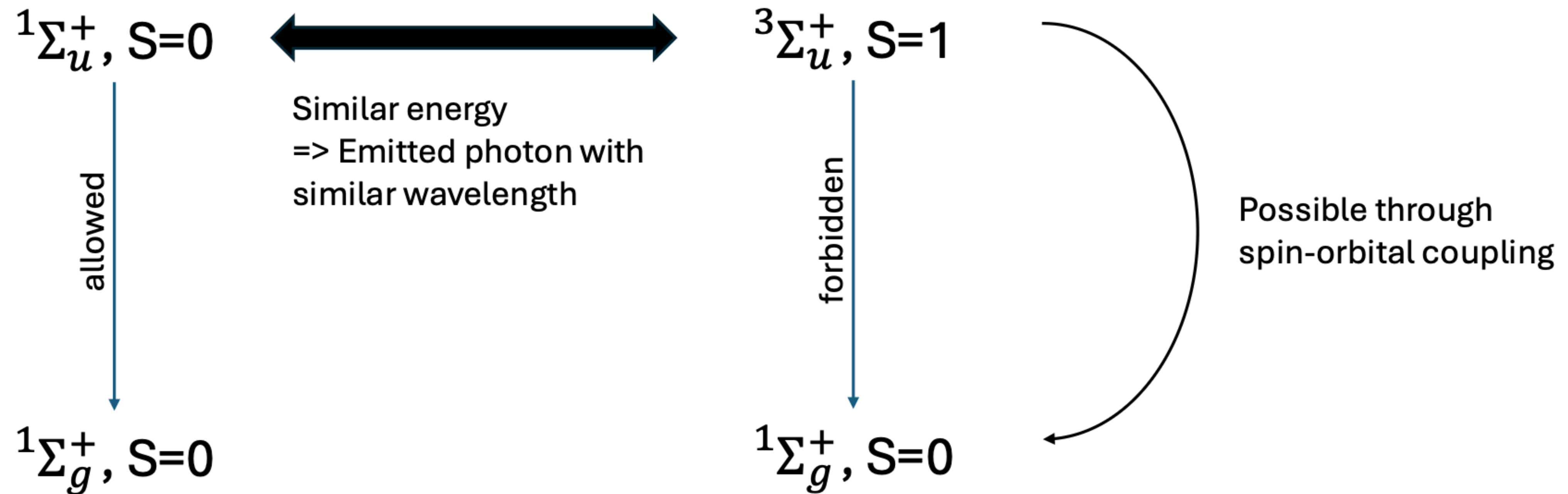

# Exercise: time decays from Fermi's rule

- How well can we quickly derive the time decays of the singlet and triplet state?
- A few quick hand-written notes to help you



# Exercise: time decays from Fermi's rule

- How well can we quickly derive the time decays of the singlet and triplet state?

FERMI GOLDEN RULE

$$\frac{1}{\tau_{\text{DECAY}}} = \Gamma_{i \rightarrow f} = \frac{2\pi}{\hbar} |\langle f | H' | i \rangle|^2 \rho(E_f)$$

**SINGLET**  $H' = -e\vec{r} \cdot \vec{E}(\vec{r}_0) \equiv -\vec{d} \cdot \vec{E}(\vec{r}_0)$

$$|\langle f | H' | i \rangle|^2 \approx |\vec{d}|^2 \quad \rho(E_f) \approx \omega_{if}^3$$

**TRIPLET**  $H'_{S_0} \sim \vec{L} \cdot \vec{S} \quad |f\rangle = |T\rangle + \alpha|S\rangle$

$\langle S_0 | S \rangle \neq 0$  BUT  $\langle S_0 | T \rangle = 0$   
 $\alpha \approx \frac{1}{\sqrt{2}}$

- A few quick hand-written notes to help you

# Properties - Recombination

Kubota et al.,  
PRB 20, 1979

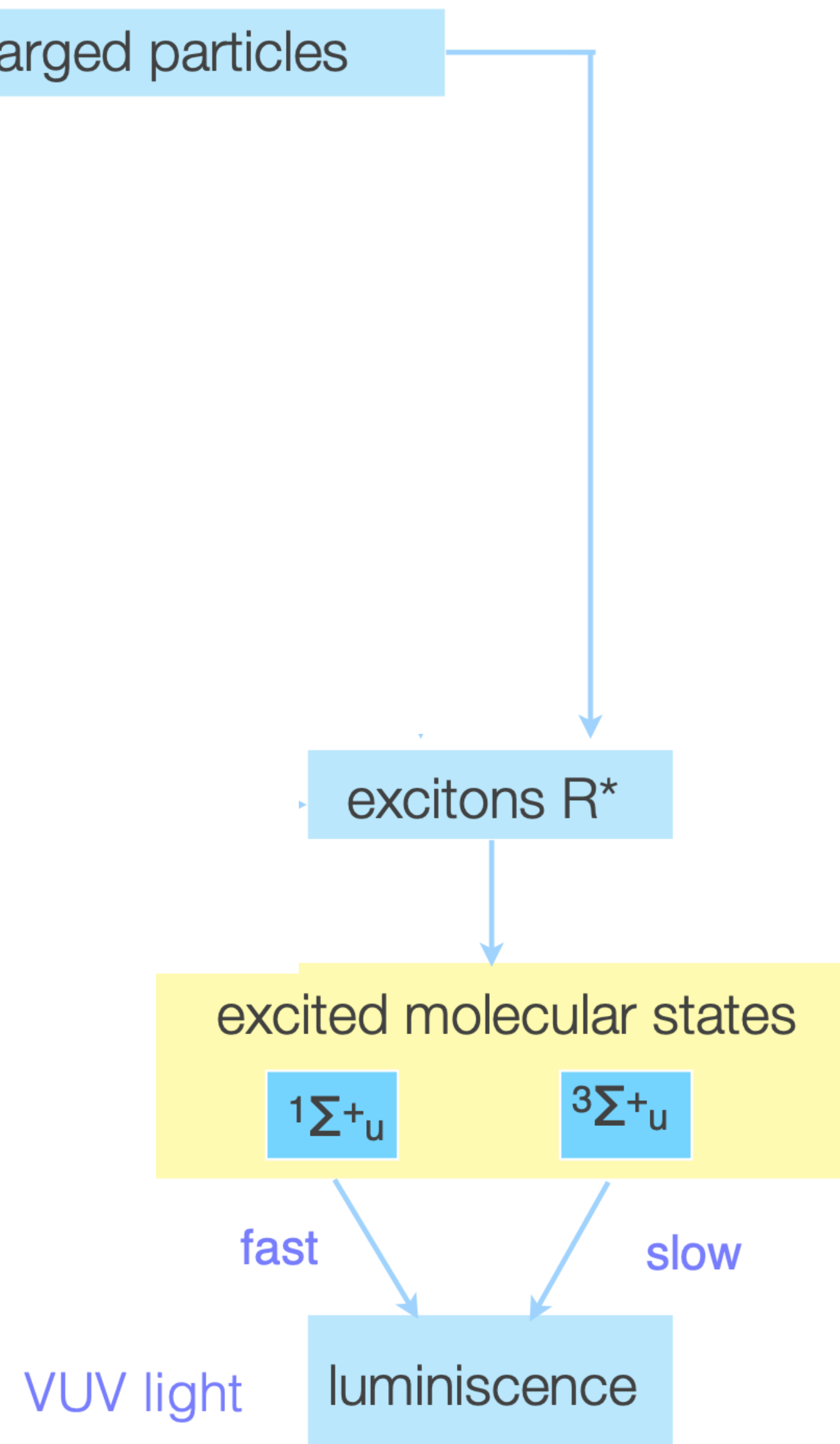

- This is a summary of the process we just examined
  - Some details removed for the sake of space and clarity...
- There is another way that photons can be produced through particle interactions

# Properties - Recombination

Kubota et al.,  
PRB 20, 1979

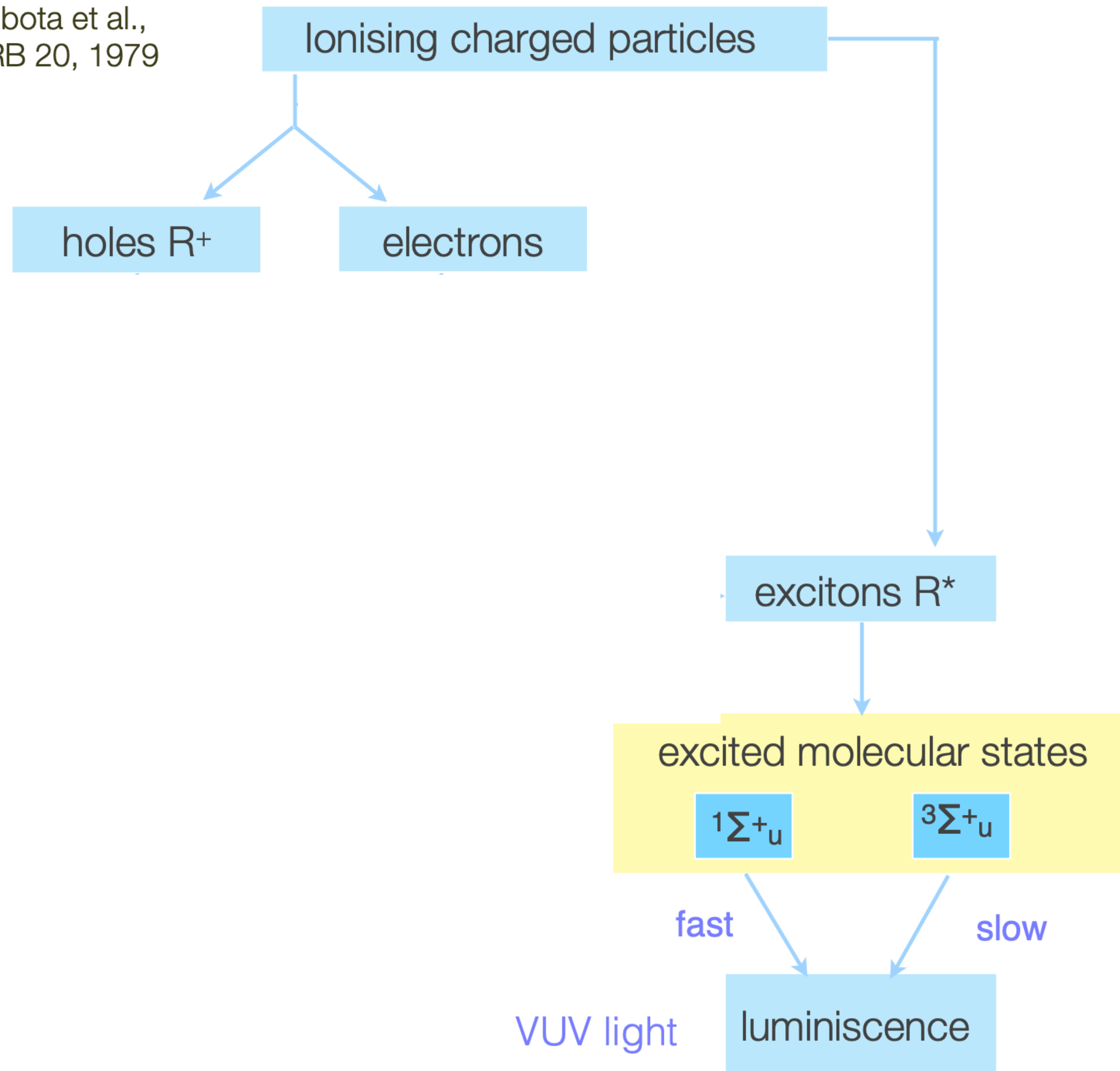

1. The charged particle interacts with the noble element, producing electrons and charged atoms

# Properties - Recombination

Kubota et al.,  
PRB 20, 1979

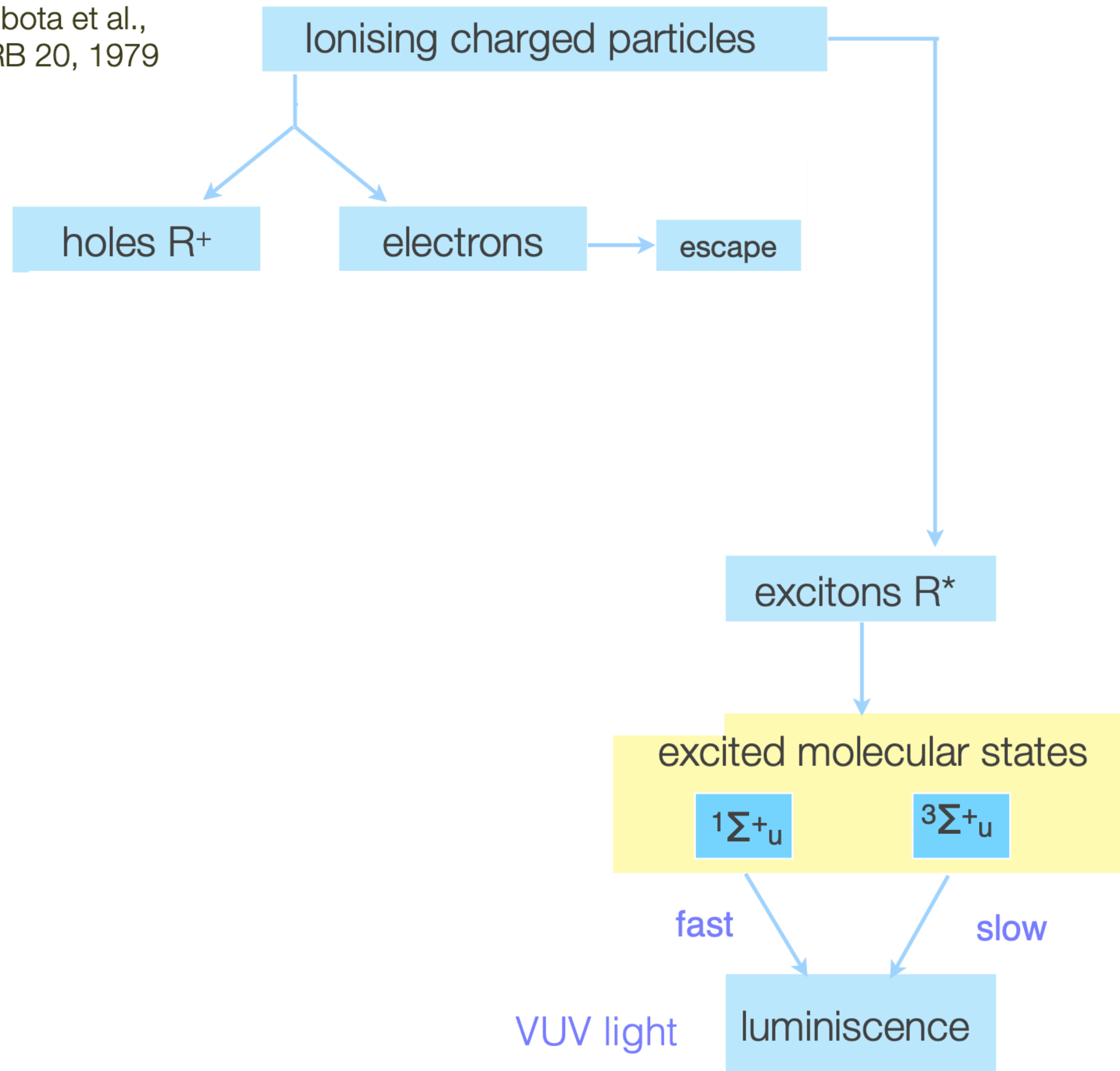

1. The charged particle interact with the noble element, producing electrons and charged atoms
2. Some of those electrons leave the area and we don't care about them any more (for this process...)

# Properties - Recombination

Kubota et al.,  
PRB 20, 1979

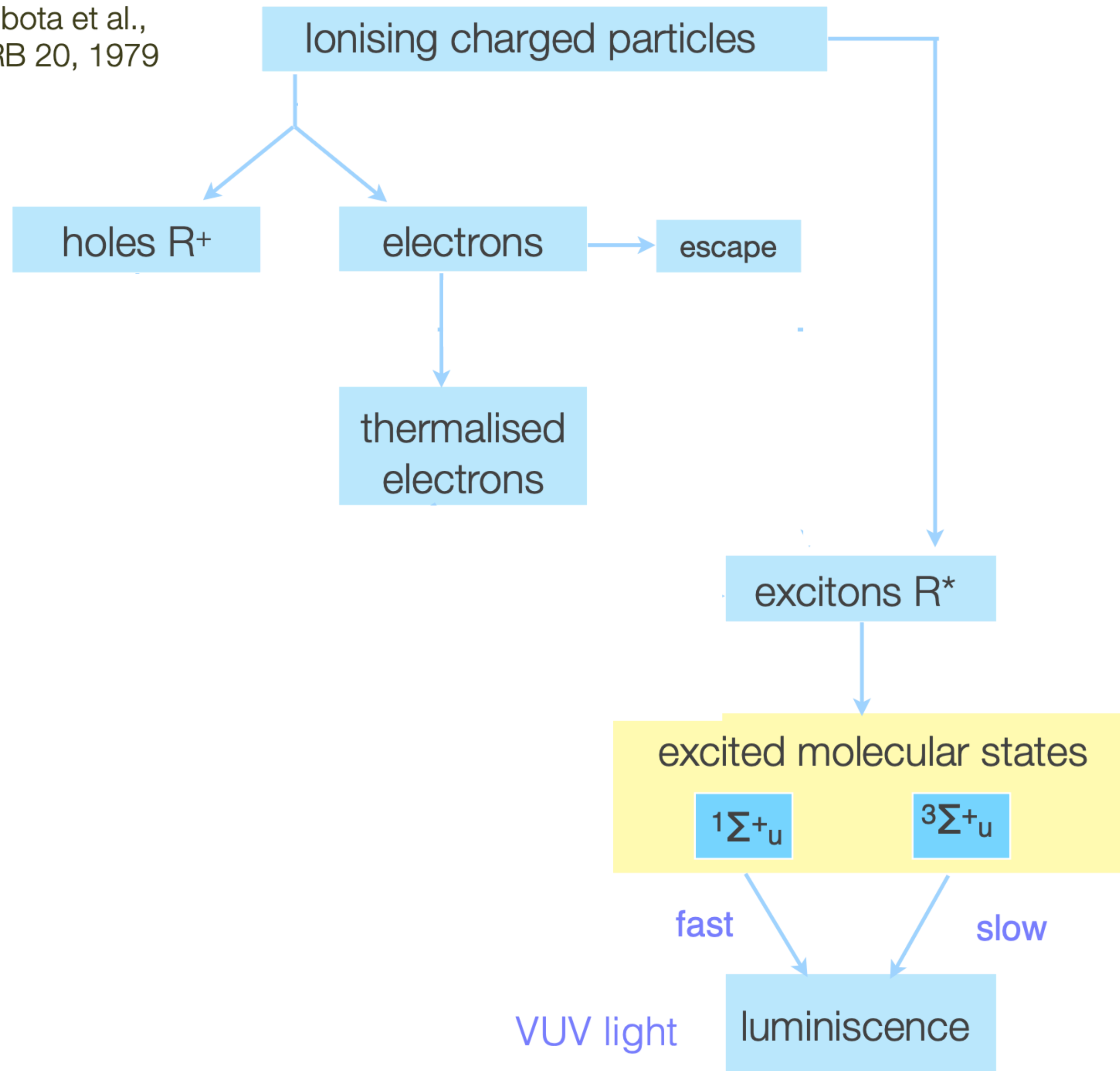

1. The charged particle interact with the noble element, producing electrons and charged atoms
2. Some of those electrons leave the area and we don't care about them any more (for this process...)
3. Other electrons are thermalized

# Properties - Recombination

Kubota et al.,  
PRB 20, 1979

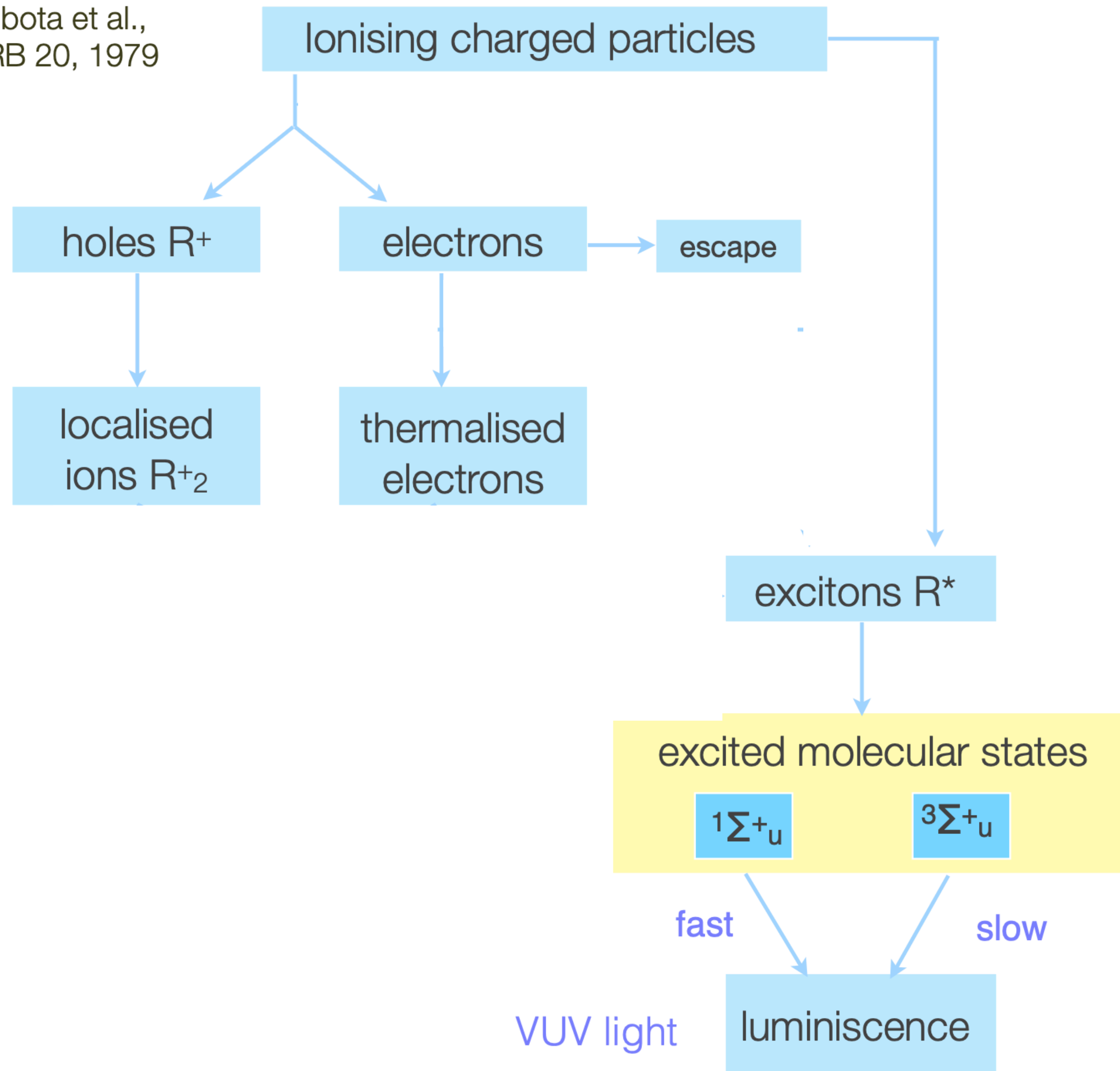

1. The charged particle interact with the noble element, producing electrons and charged atoms
2. Some of those electrons leave the area and we don't care about them any more (for this process...)
3. Other electrons are thermalized
4. The ions can form into pairs

# Properties - Recombination

Kubota et al.,  
PRB 20, 1979

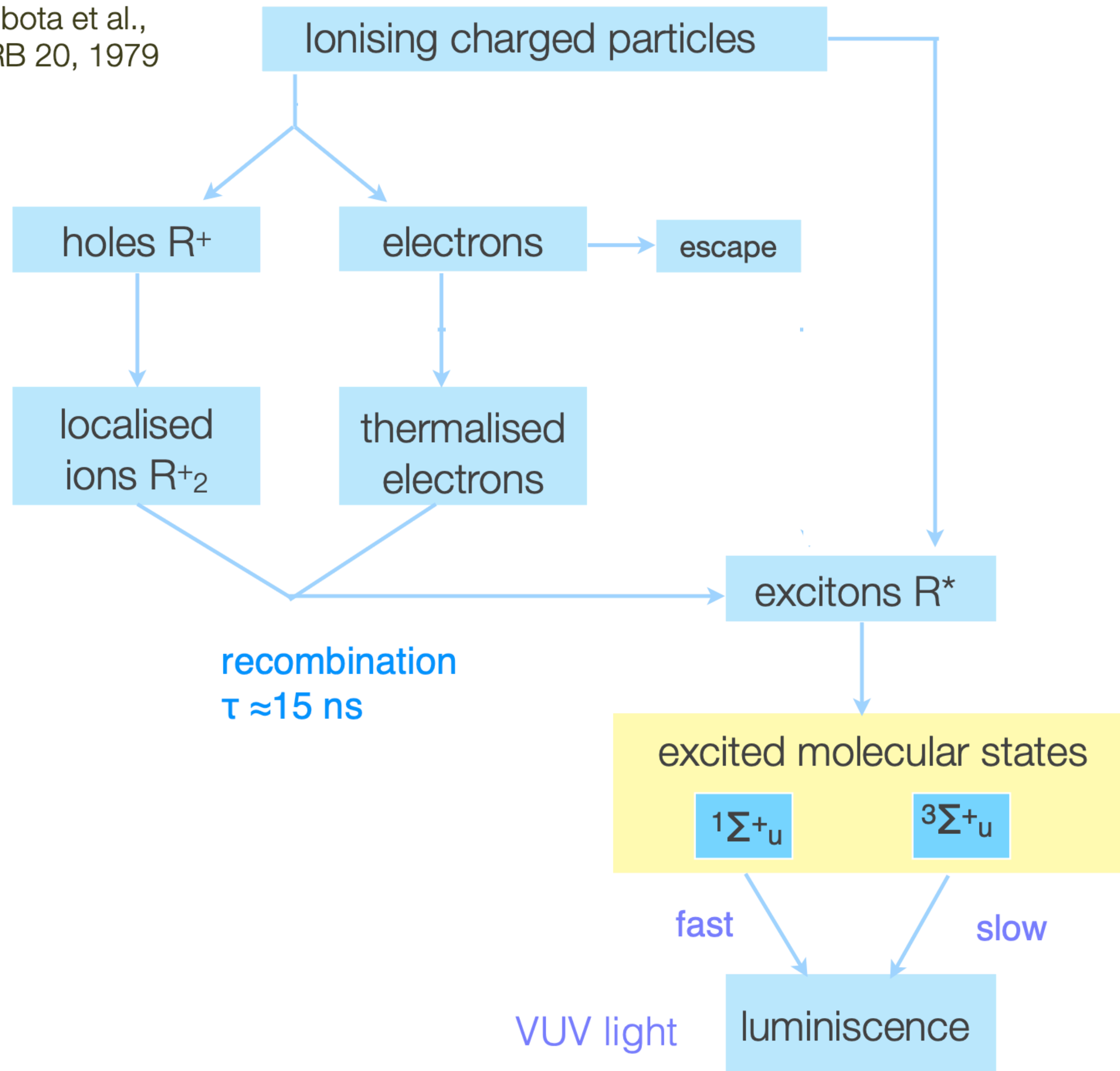

1. The charged particle interact with the noble element, producing electrons and charged atoms
2. Some of those electrons leave the area and we don't care about them any more (for this process...)
3. Other electrons are thermalized
4. The ions can form into pairs
5. Those pairs find an electron and recombine to make an excited state and the process follows

# Properties - Recombination

Kubota et al.,  
PRB 20, 1979

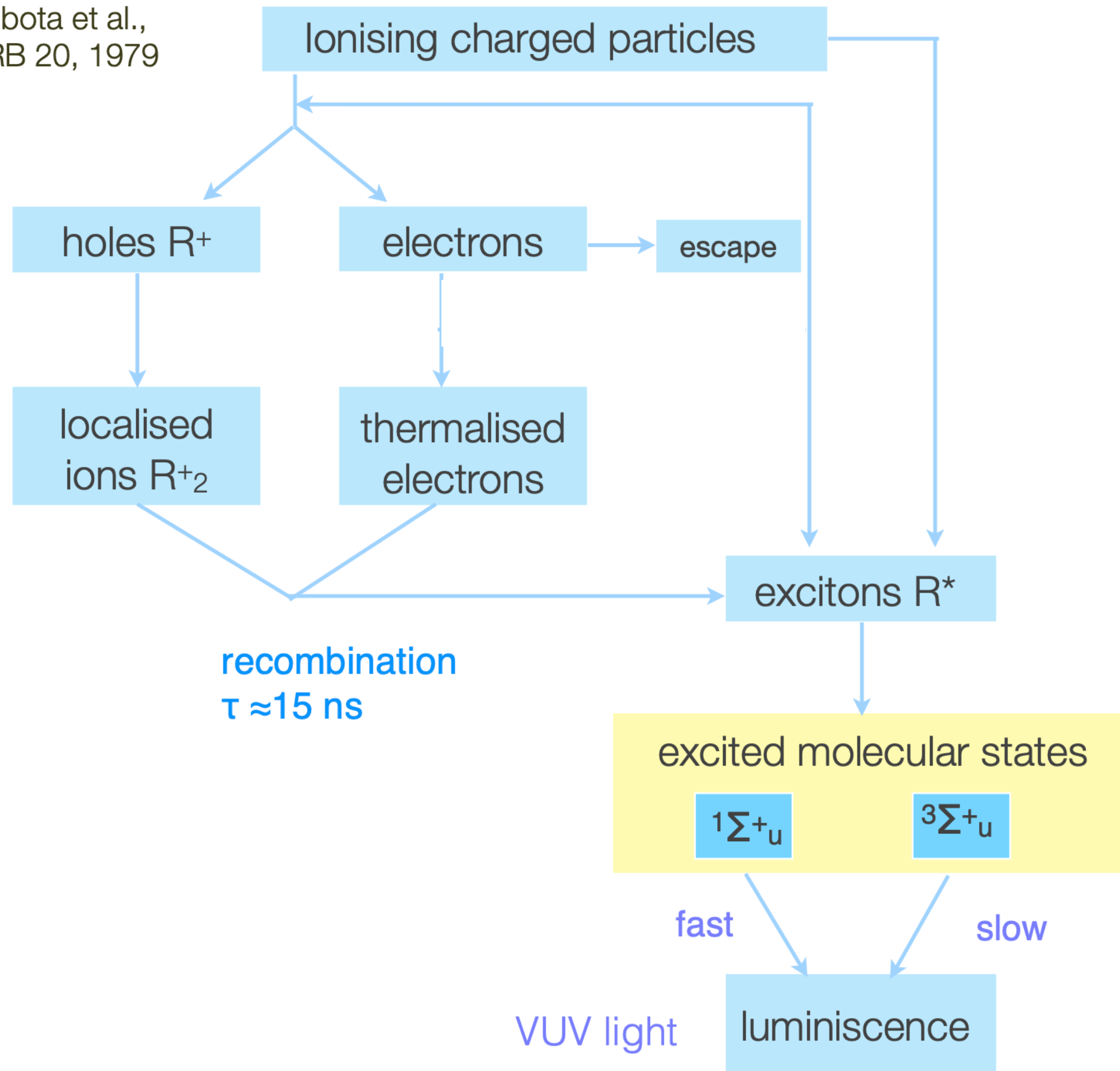

1. The charged particle interact with the noble element, producing electrons and charged atoms
2. Some of those electrons leave the area and we don't care about them any more (for this process...)
3. Other electrons are thermalized
4. The ions can form into pairs
5. Those pairs find an electron and recombine to make an excited state and the process follows
6. There is also feedback with the excited state system

# Properties - Scintillation

- The energy change is often presented as shown for xenon

- A. Initial excitation
- B. Formation of dimer
- C. Combine with electrons to form excited states
- D. Collisions or transitions
- E. Lowest energy excimer state
- F. Final decay, two lifetimes shown

- Note the two energy states for the excimer, as we stated earlier

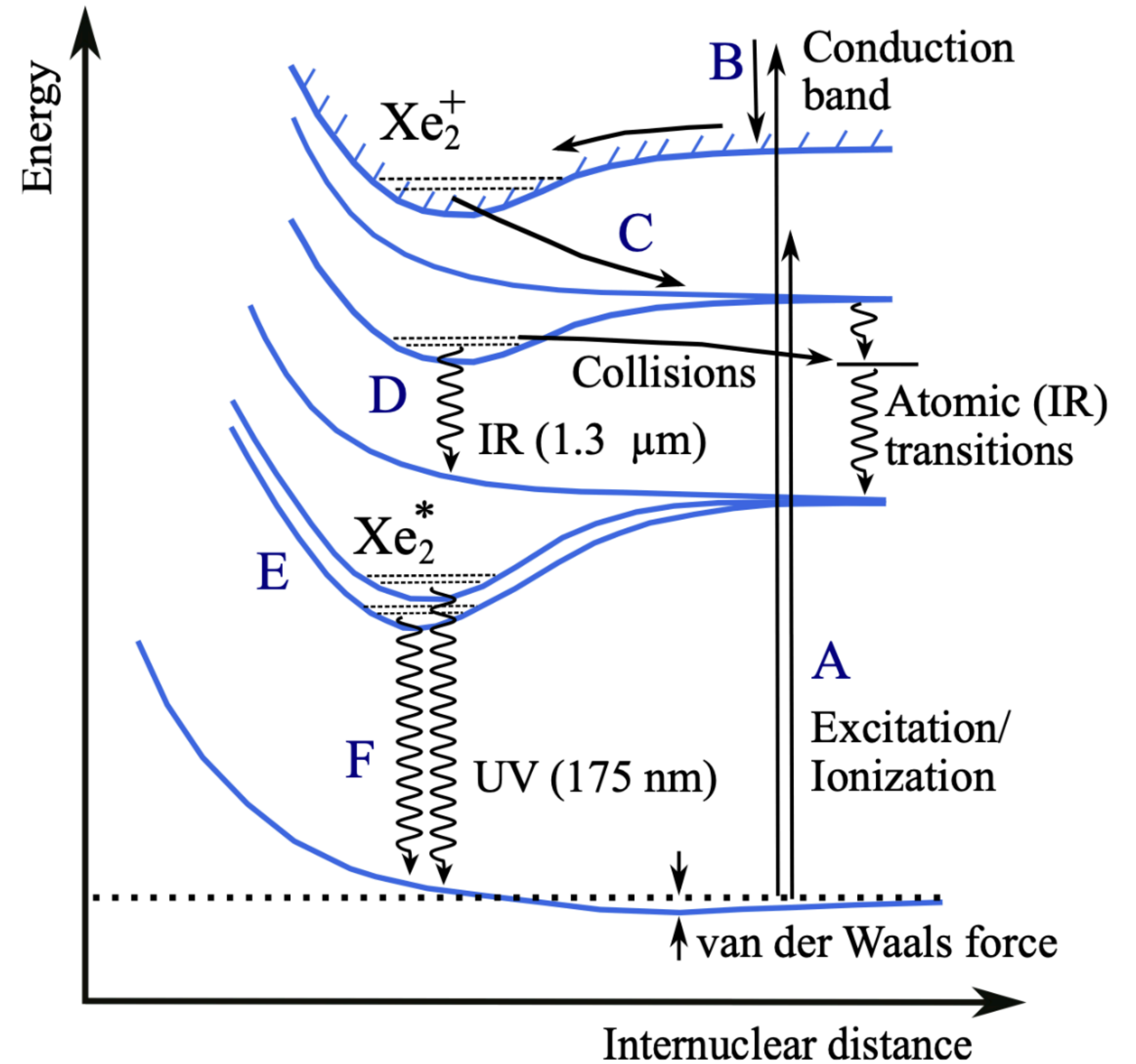

Credit: arXiv:2303.09344

# Scintillation Photon Energy

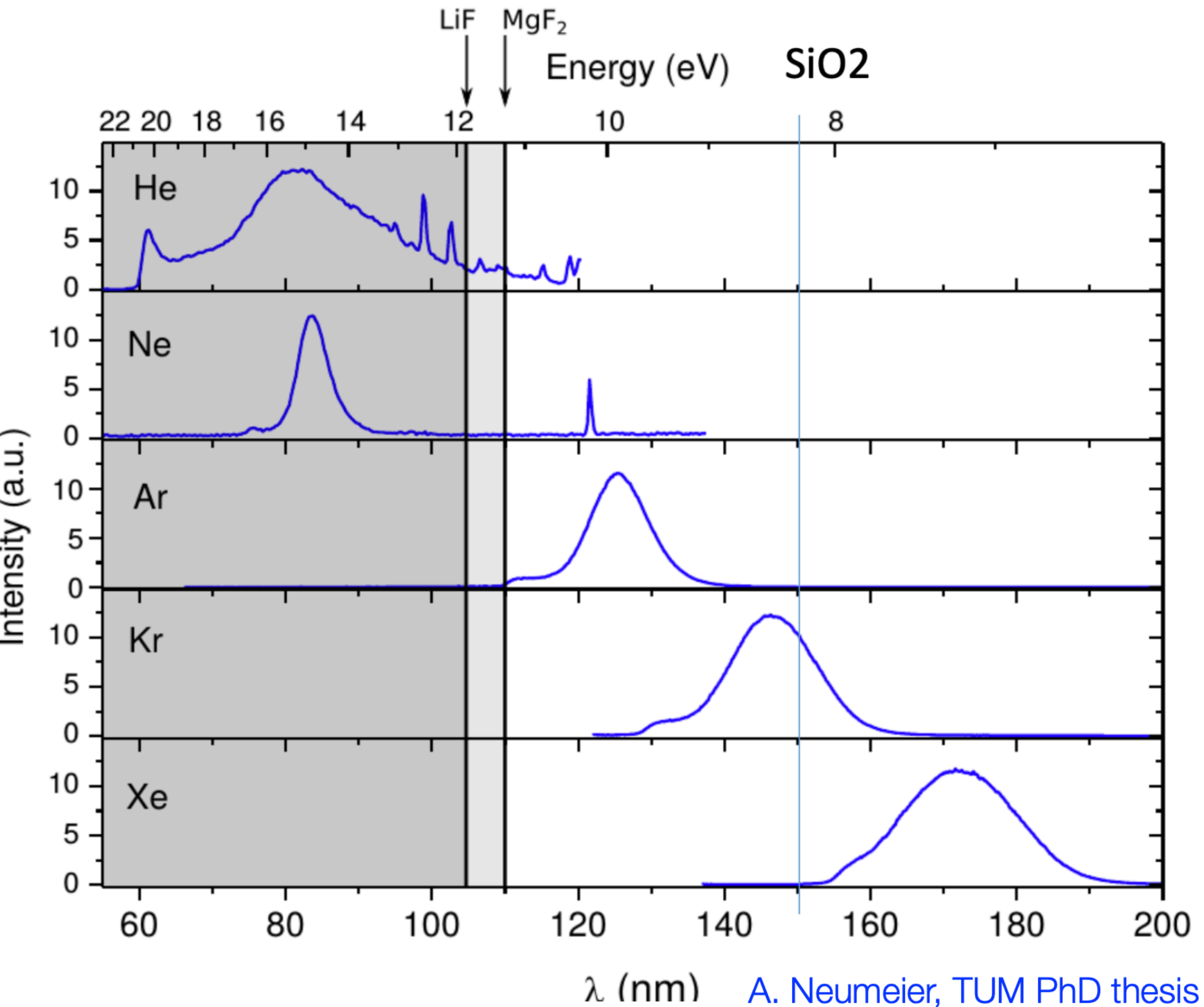

- The different elements have different energy “schemes”
- This leads to different wavelengths of photons produced
- Important here is the “transparency” lines which are shown
- It can be difficult to choose something out of which to make your detector

# Scintillation Photon Energy

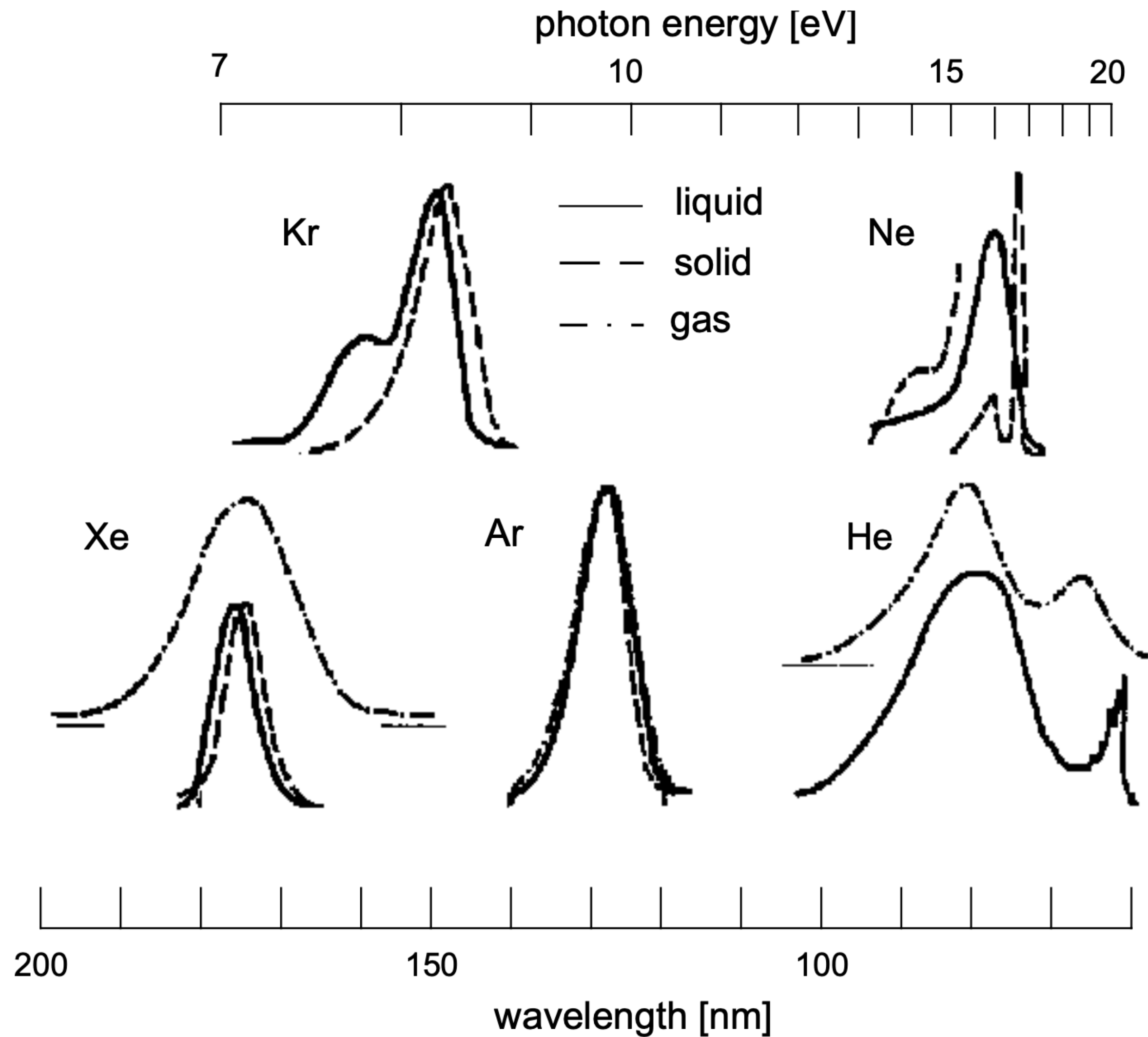

- The state of the noble element also has some effect on the wavelength of photons produced
- As an example, xenon gas has a wide spectrum so it can be useful
- Changing to solid or liquid reduces that spread



# Observable signals

- Let's define  $W_{ph}$  as the energy required to produce a single photon, in contrast to the  $W_e$  value we used earlier to define the energy of ionization

$$W_{ph} = \frac{E_0}{N_{ph}} = \frac{E_0}{N_{ex} + rN_i} \quad W_e = \frac{E_0}{N_e} = \frac{E_0}{N_i - rN_i} = \frac{E_0}{N_i(1 - r)}$$

- Where  $r$  is the recombination fraction (how many electrons find ions) and strongly depends by an electric field, if applied.
- The number of observable quanta is conserved for any electric field

$$N_q = N_{ph} + N_e = \frac{E_0}{W}$$

# Who cares?

- It's good to take a break every once in a while and ask yourself: who cares?
- Who cares about all these W values and all these process? Are they going to do anything for us? Will knowing this make my life better in any meaningful way?
- Maybe...

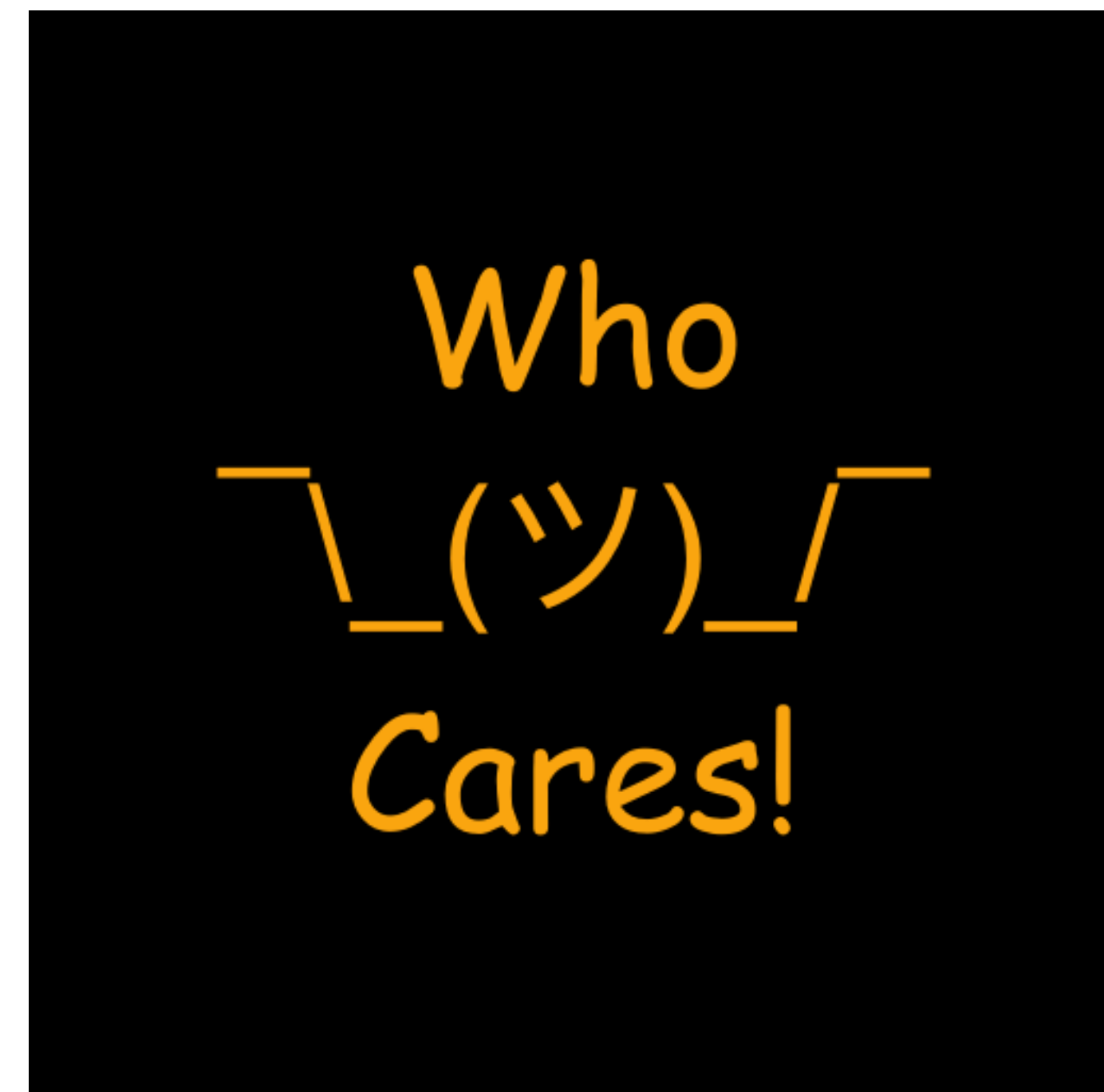

# Particles care

- Turns out that particles actually care
- We have these different excitation channels, and the distribution of emitted scintillation photons across these channels varies with the inducing particle
  - It actually varies with the linear energy transfer (LET) of that particle
- This means we can tell particles apart by how they interact in the detector
  - Telling particles apart is almost literally the only job low-background detectors have!



# Particles care

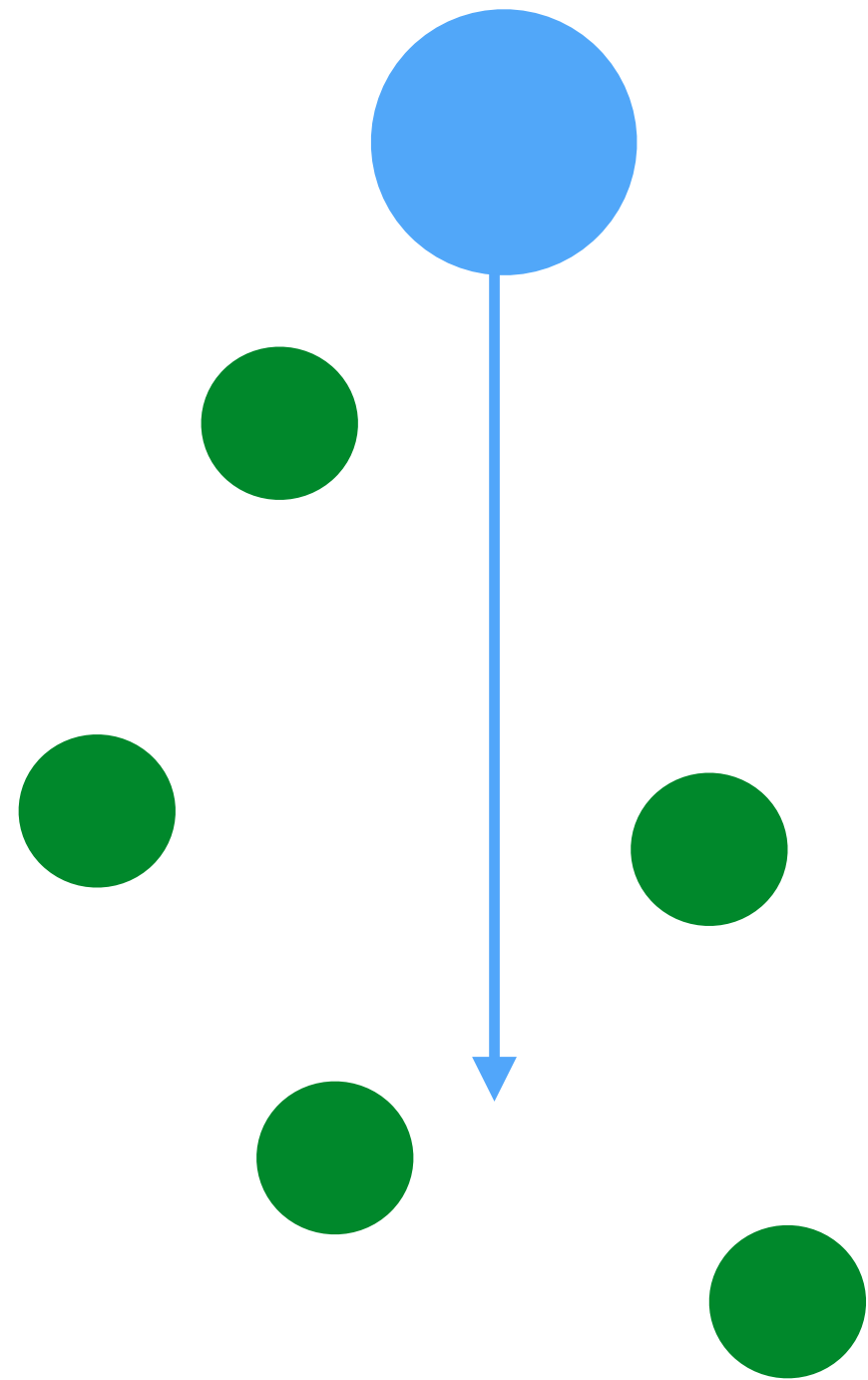

- How does this work?
- Particles have different mechanisms for energy loss depending on their charge, mass, and any other properties
- As they travel through the medium, the ratio of excitation and ionization they create varies
- Note that this does not include the heat imparted to the medium...

# Particles care

## Electrons

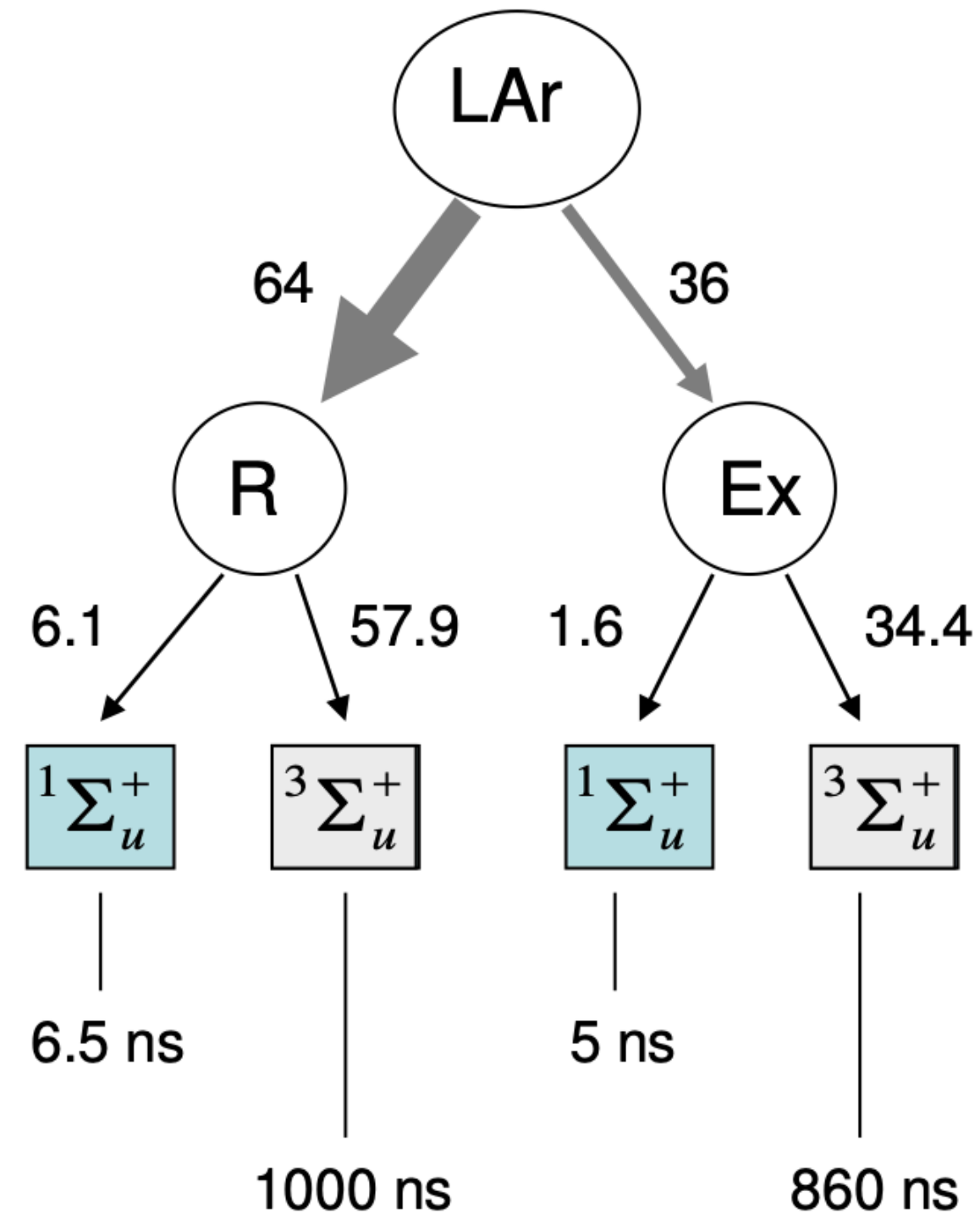

- So what we see is something like this
- Here R is the recombination channel and Ex is the excitation channel
- The numbers are in percent, and the two excited states are also shown
- This is for “fast” electrons (0.5-1MeV)
- We can do some more cool tricks...



# Particles care

## Electrons

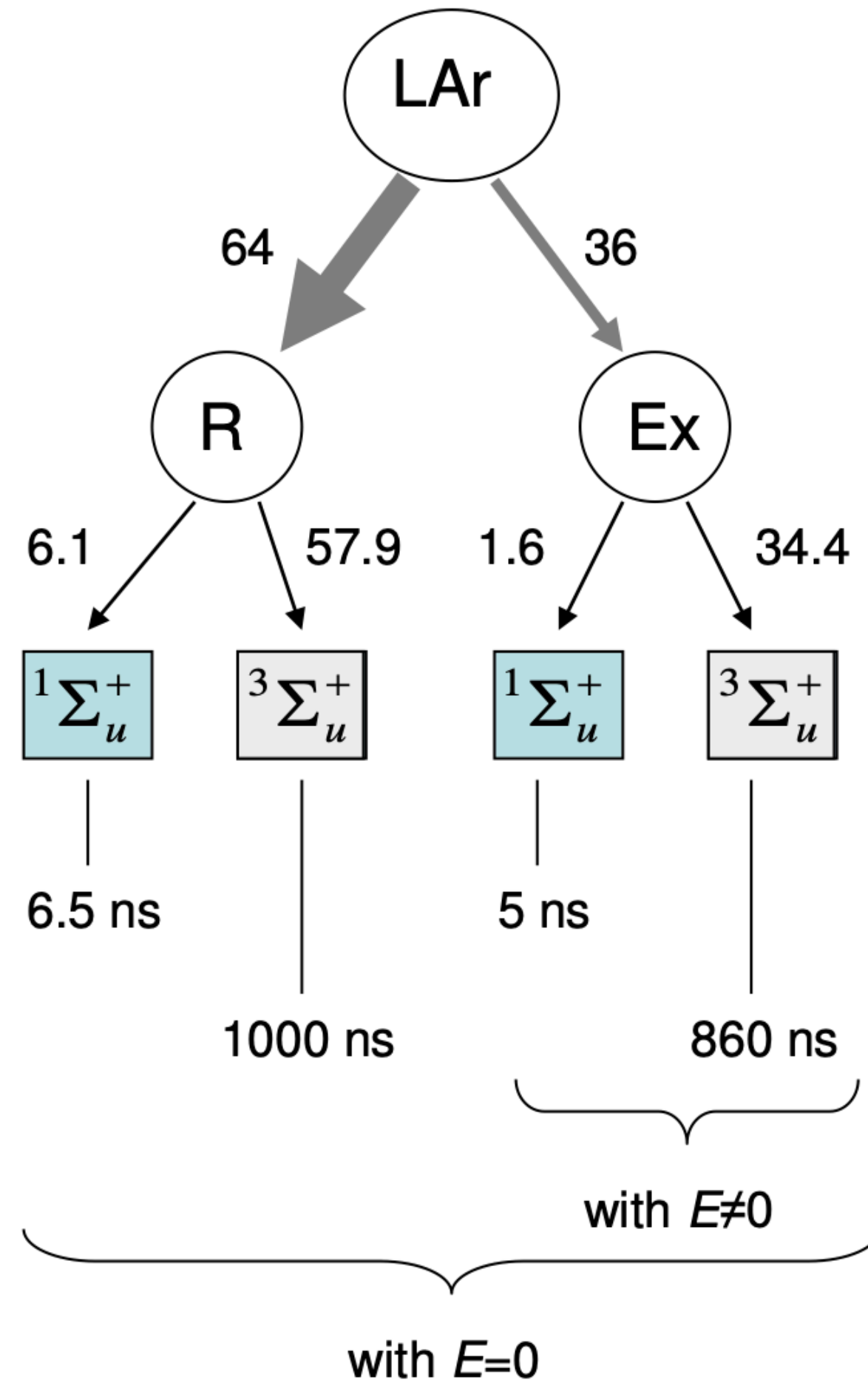

- As discussed before, we can turn on an electric field, effectively turning off the recombination channel
- This means we get only the excitation channel, and it changes the light output considerably



# Particles care

- The fractions also obviously change with the element
- This gives some amount of fine tuning (provided there is a choice of element possible)
- But this is only for electrons...

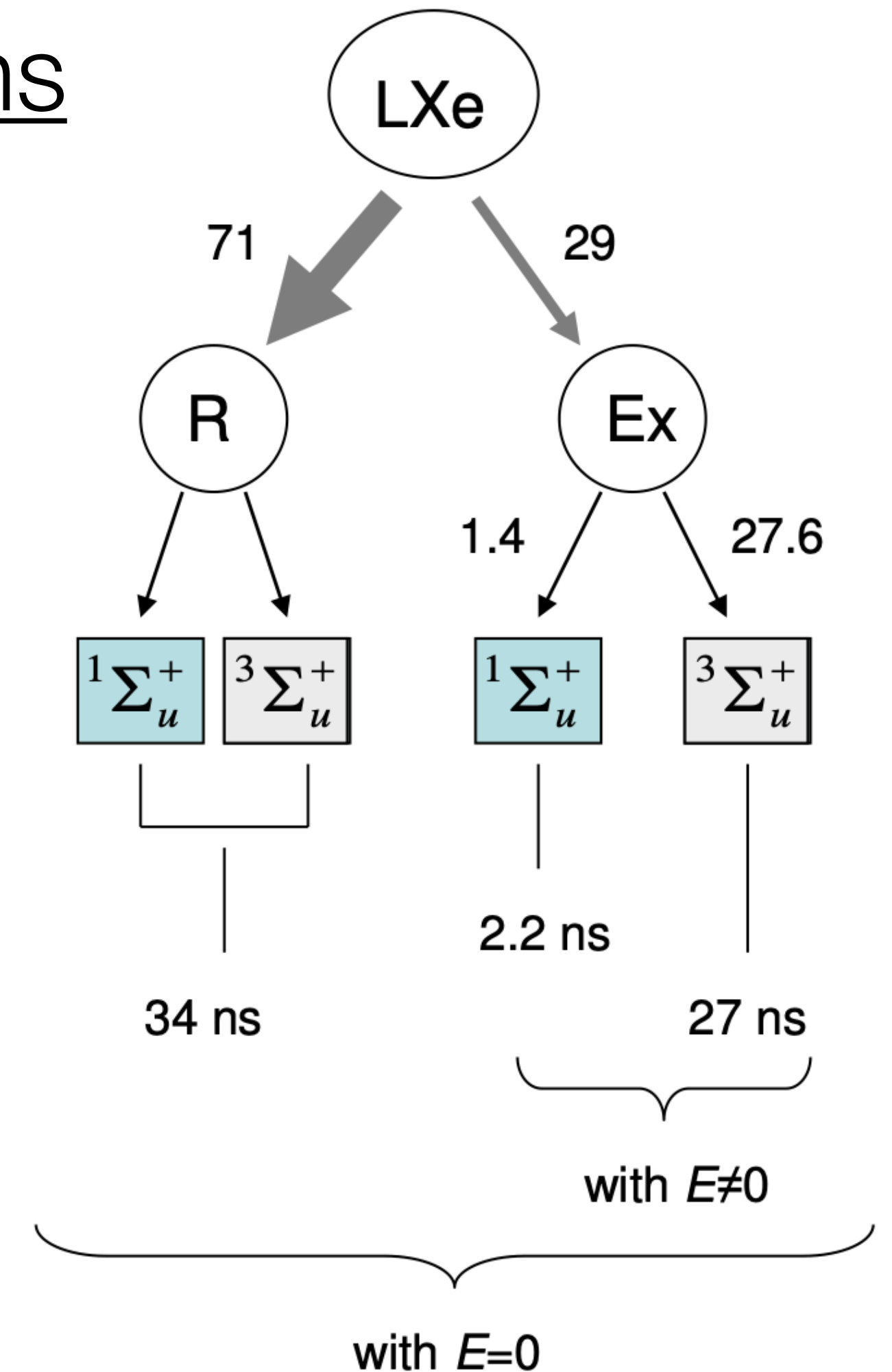
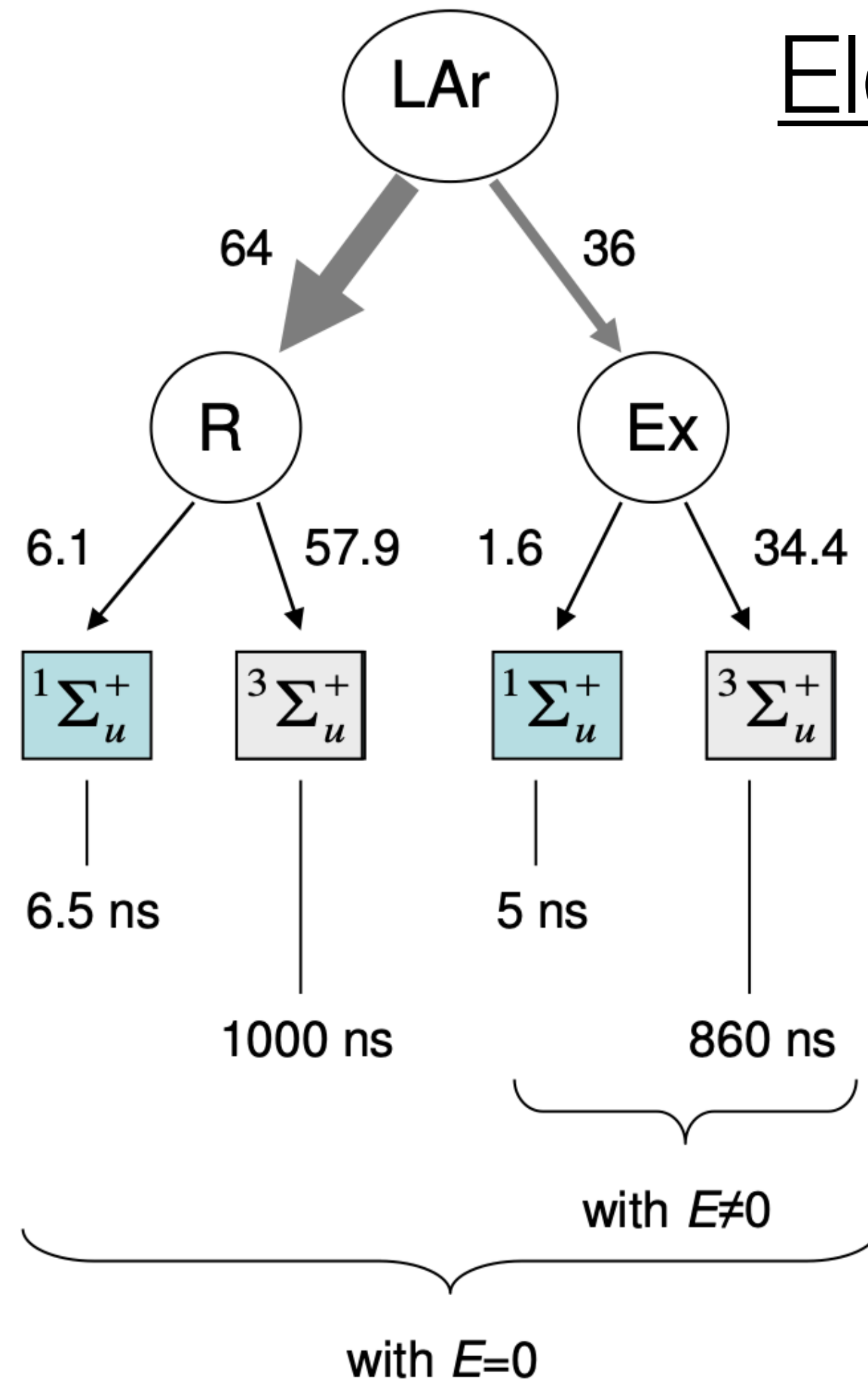

Credit: V Chepel and H Araújo 2013 JINST 8 R04001

# Particles care

## Electrons

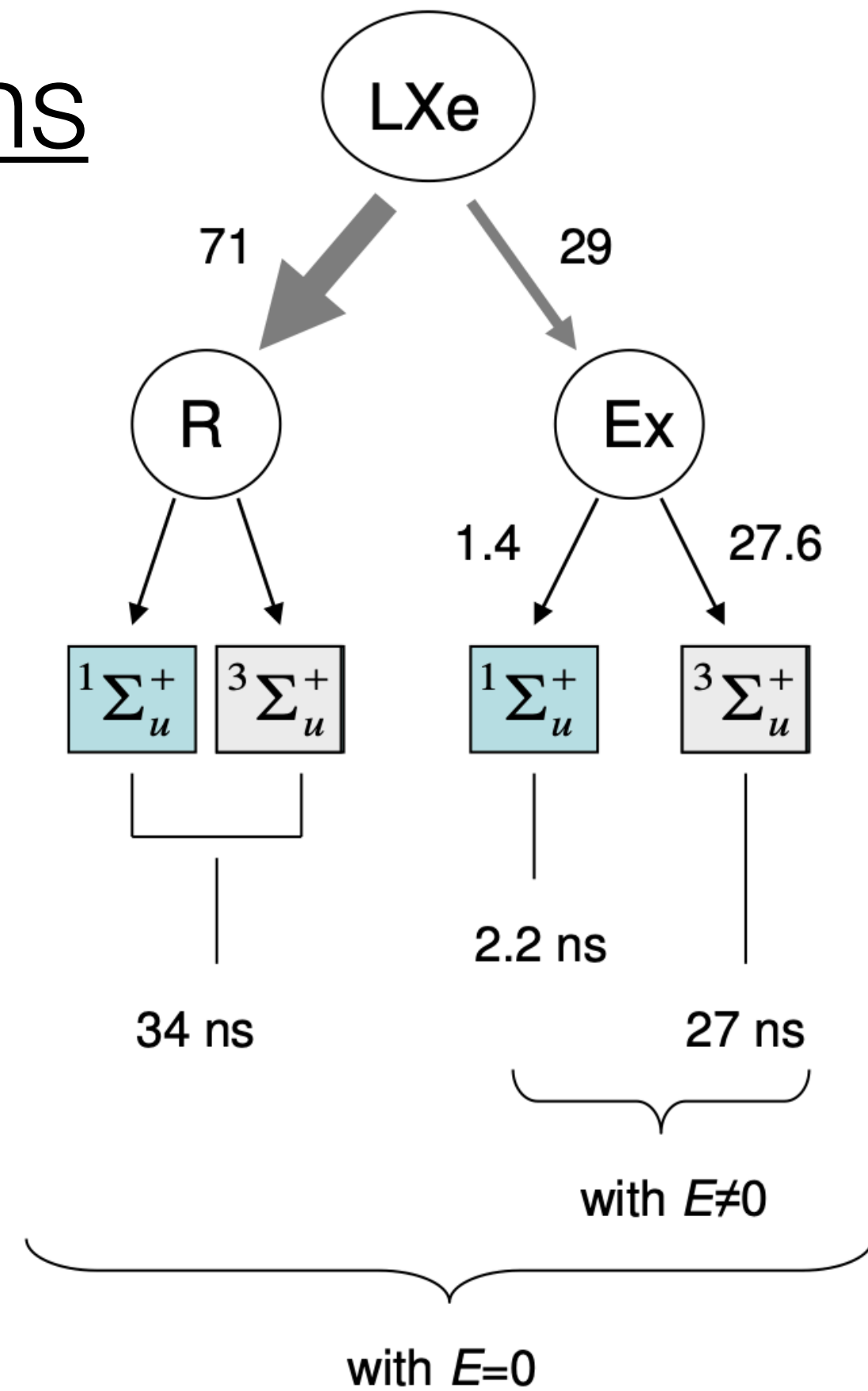
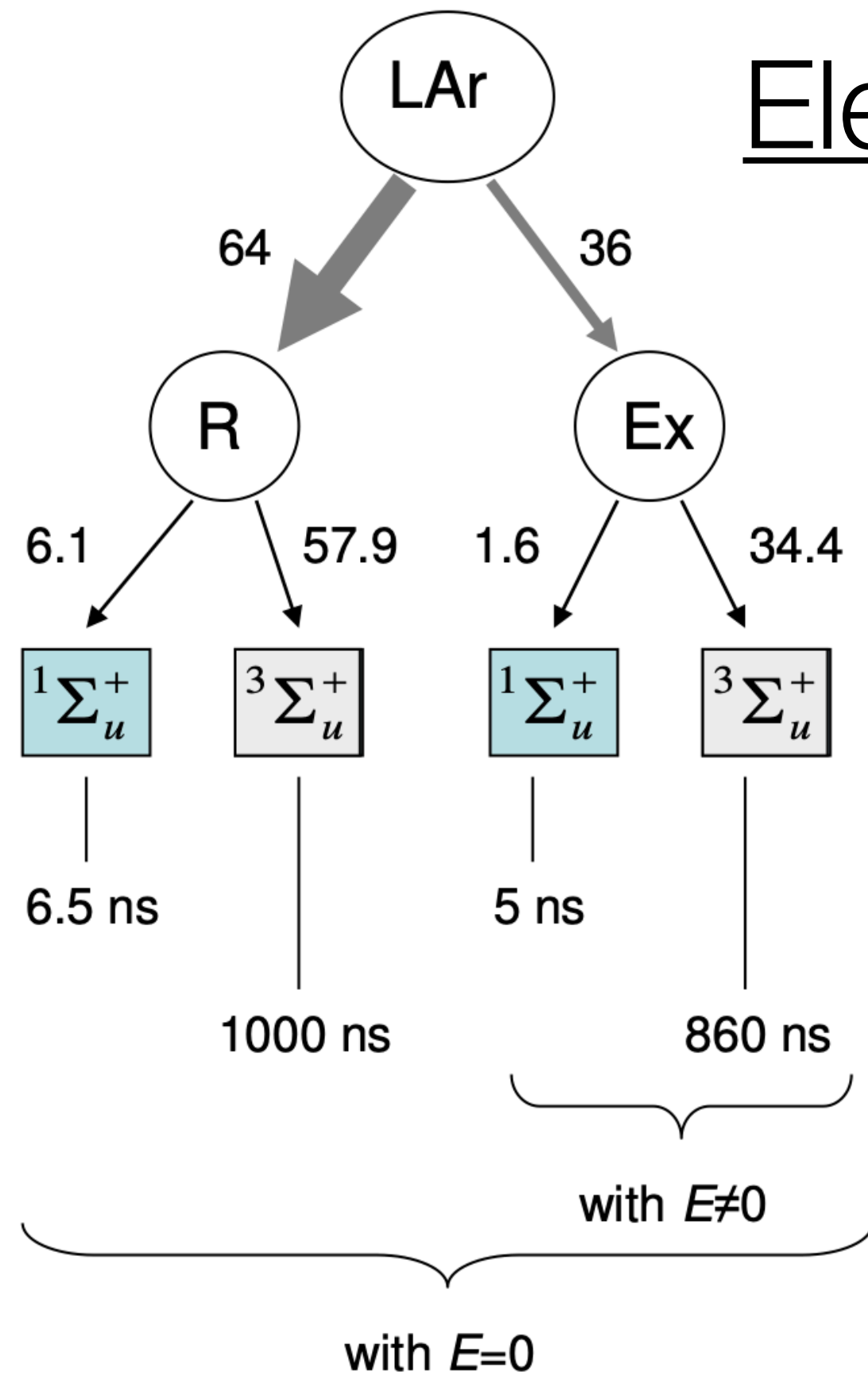

## Alphas

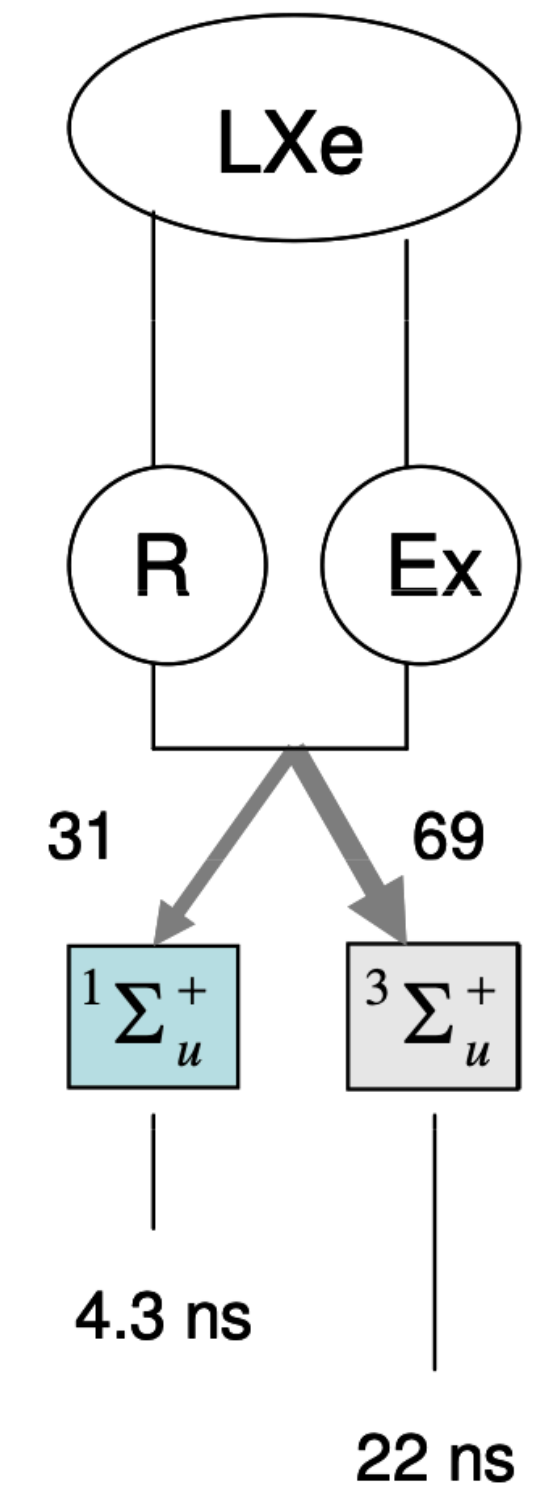
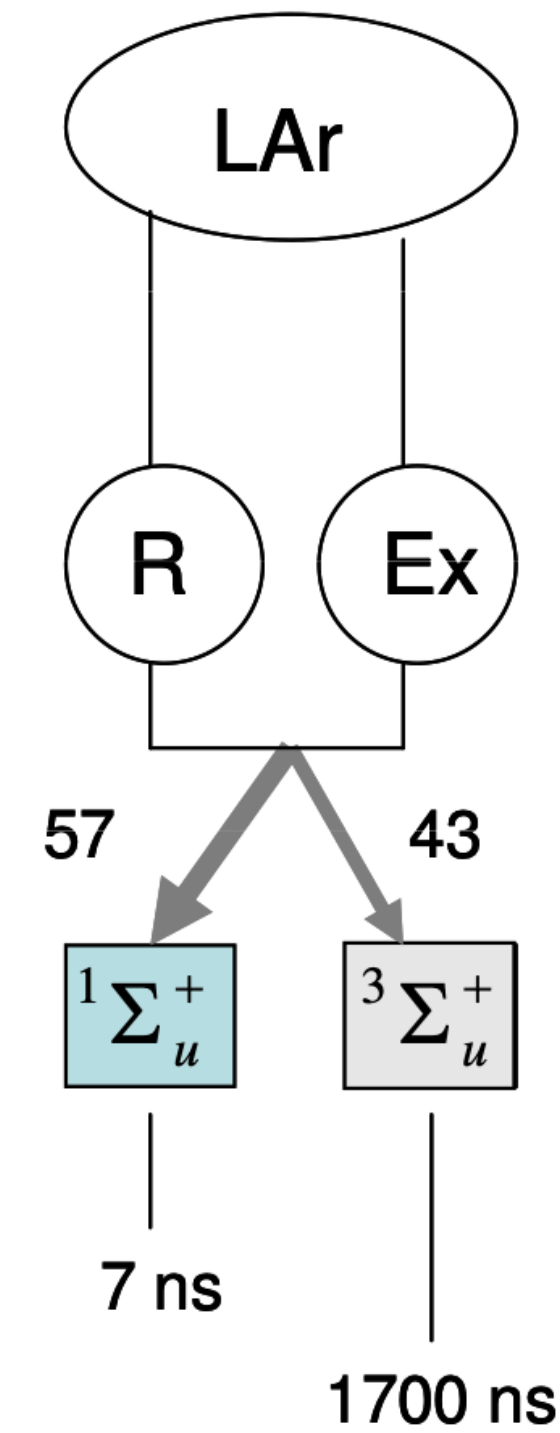

Credit: V Chepel and H Araújo 2013 JINST 8 R04001

- Now we can tell particles apart!



# Discrimination

- OK, I've claimed we can tell particles apart, but how does this actually work?
- As we saw, the fraction of light coming out from the different processes affects the timing of the signal
- We can use the times that light is detected to tell these things apart!

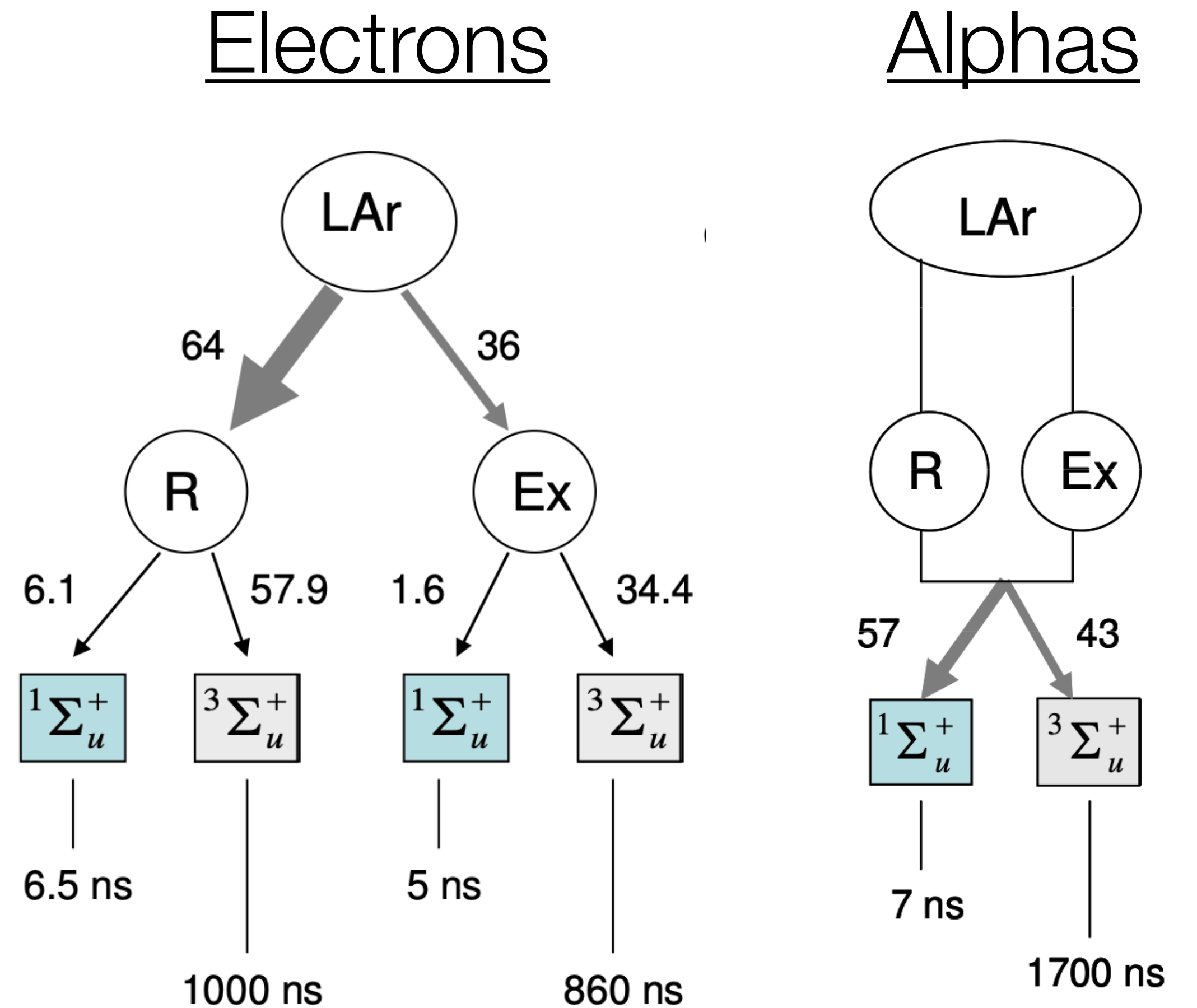

Credit: V Chepel and H Araújo 2013 JINST 8 R04001



# Discrimination

- In liquid argon, shown here, for electrons the vast majority of the light (92.3%) is produced in the long process (the triplet state)
- For alphas, much more light (57%) is produced in the short one (the singlet state)
- If we get a pulse that has more light produced “later”, we can be pretty sure it was an electron

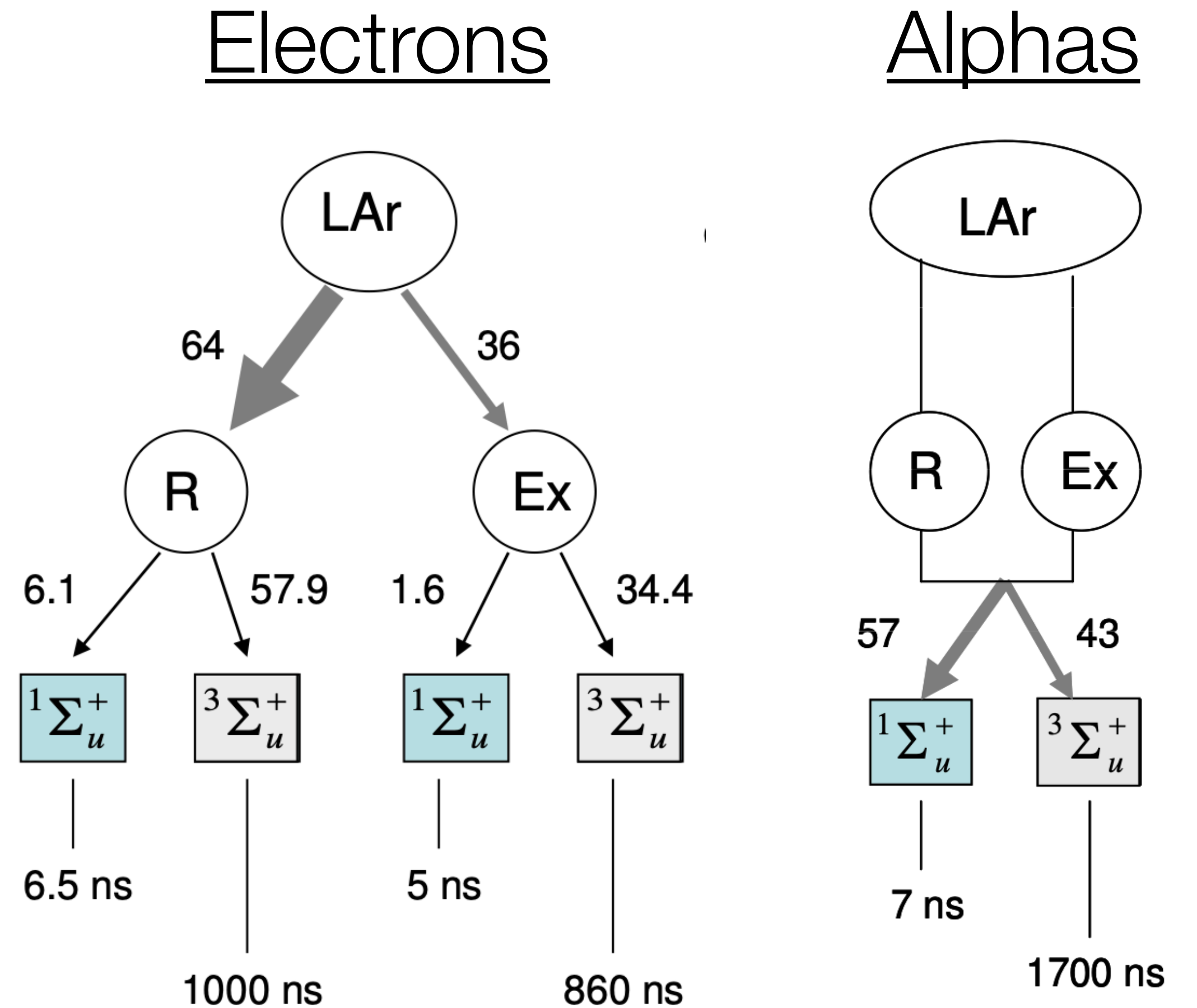

Credit: V Chepel and H Araújo 2013 JINST 8 R04001



# Discrimination

- In the case of the electron, most energy is lost through “electronic stopping” — interactions with the electrons of the target atom
- This means more recombinations and that’s slow
- In the case of alphas, much more is through “nuclear stopping” in which the interaction is with the nucleus

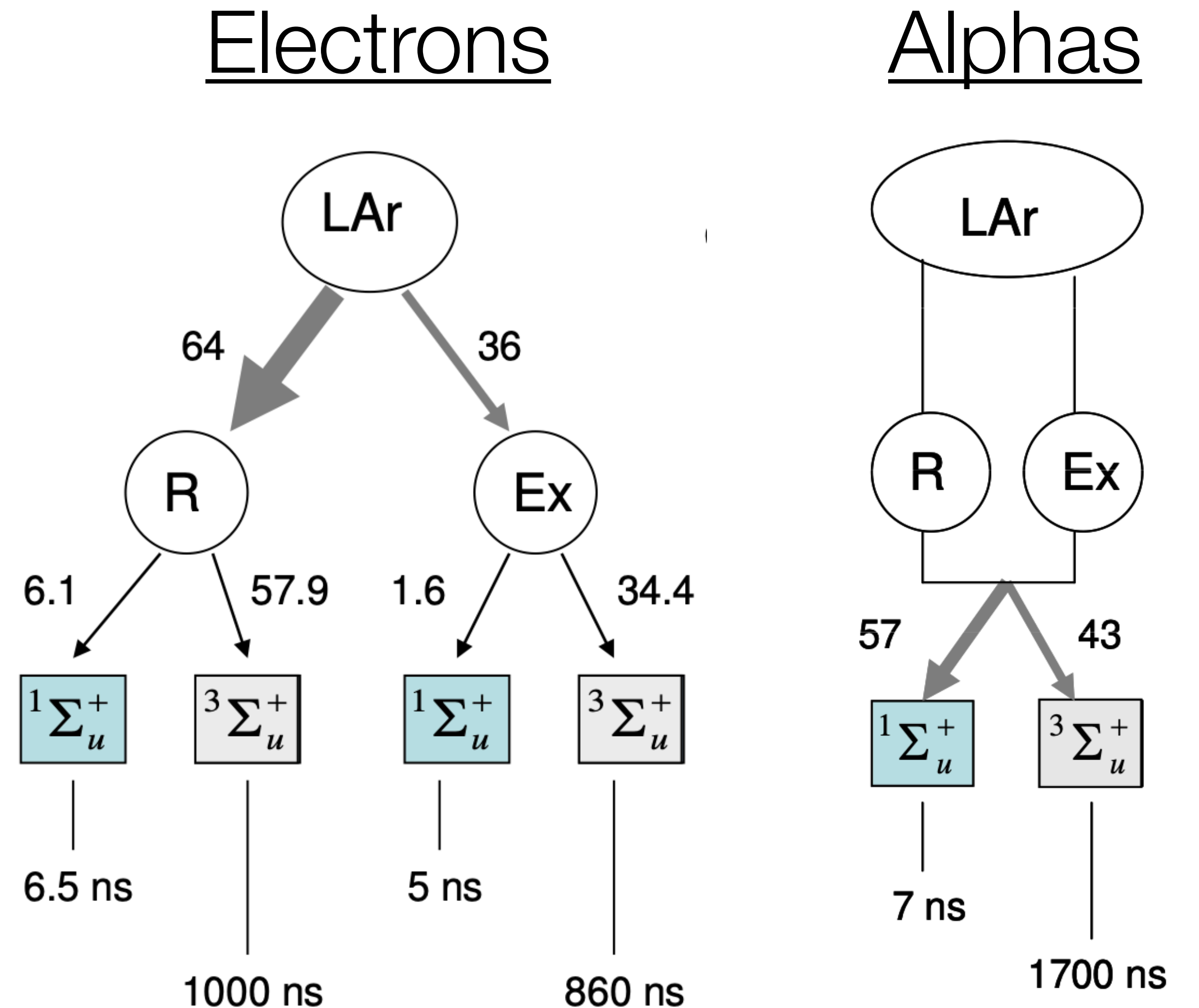

Credit: V Chepel and H Araújo 2013 JINST 8 R04001



# Exercise: Pulse shape in argon vs xenon

- Write a toy-Monte Carlo plotting a histogram of the photoelectron released time (Intensity/counts on the y-axis, emission time on the x-axis)?



# Exercise: Pulse shape in argon vs xenon

- Write a toy-Monte Carlo plotting a histogram of the photoelectron released time (Intensity/counts on the y-axis, emission time on the x-axis)?
- Here is a reminder on how to write a toy-MC in ROOT, but similar methods are available in python

```
void toyMC_histograms() {
    //Use Monte Carlo numeric generators to fill a 1D histogram and print these on a file
    TRandom3 *ran = new TRandom3(12345); // seed for reproducibility
    const int N = 100000; // number of events

    // Parameters of the two Gaussians
    double mean1 = -2, sigma1 = 2.0;
    double mean2 = 2.0, sigma2 = 0.7;

    double p0 = 0.5; // probability of choosing Gaussian 1

    //Define three histograms, two 1Dimensional, one 2Dimensional
    TH1D *h = new TH1D("h", "Two merging Gaussians; x; Events", 200, -5, 5);
    TH1D *h2 = new TH1D("h2", "Two merging Gaussians; x; Events", 200, -5, 5);

    TH2D *h3 = new TH2D("h3", "2D Gaussian; x; y; Events", 200, -5, 5, 200, -5, 5 );

    for (int i = 0; i < N; i++) { //Loop to sample N (x,y) couple, ina toy-Monte Carlo fashion, with specific random distributions
        double x, y;
        if (ran->Uniform() < p0){
            x = ran->Gaus(mean1, sigma1);
            y = ran->Gaus(mean1, sigma1);
        }
        else{
            x = ran->Gaus(mean2, sigma2);
            y = ran->Gaus(mean2, sigma2);
        }
        h->Fill(x); //Adds 1 event to the bin corresponding to x
        //h2->SetBinContent(i,x); //Directly sets the bin content

        //example to make the two histograms match
        int bin = h2->FindBin(x);
        h2->SetBinContent(bin, h2->GetBinContent(bin) + 1);

        h3->Fill(x,y);
    }

    TCanvas *c1 = new TCanvas("c1", "Two Gaussians", 800, 600);
    h->Draw("histo");
    TCanvas *c2 = new TCanvas("c2", "Two Gaussians; h2content", 800, 600);
```



# And energy loss: quenching

- Danish theorist Jens Lindhard studied the effects of electric field screening by electrons in solids
- Essentially this allows for the calculation of the fraction of recoil energy lost to electronic excitation  $f_n$

$$f_n = \frac{k \cdot g(\epsilon)}{1 + k \cdot g(\epsilon)}$$

Where  $\epsilon$  is the reduced energy

$$\epsilon = 11.5 E_R(\text{keV}) Z^{-7/3}$$

$k$  relates the  $dE/dx$  and the velocity of the recoiling atom

$$k = 0.133 Z^{2/3} A^{-1/2}$$

And  $g(\epsilon)$  is the ratio of electronic to nuclear stopping power

$$g(\epsilon) = 3\epsilon^{0.15} + 0.7\epsilon^{0.6} + \epsilon$$



# And energy loss: quenching

- Danish theorist Jens Lindhard studied the effects of electric field screening by electrons in solids
- Essentially this allows for the calculation of the fraction of recoil energy lost to electronic excitation  $f_n$
- In semiconductors this works really well

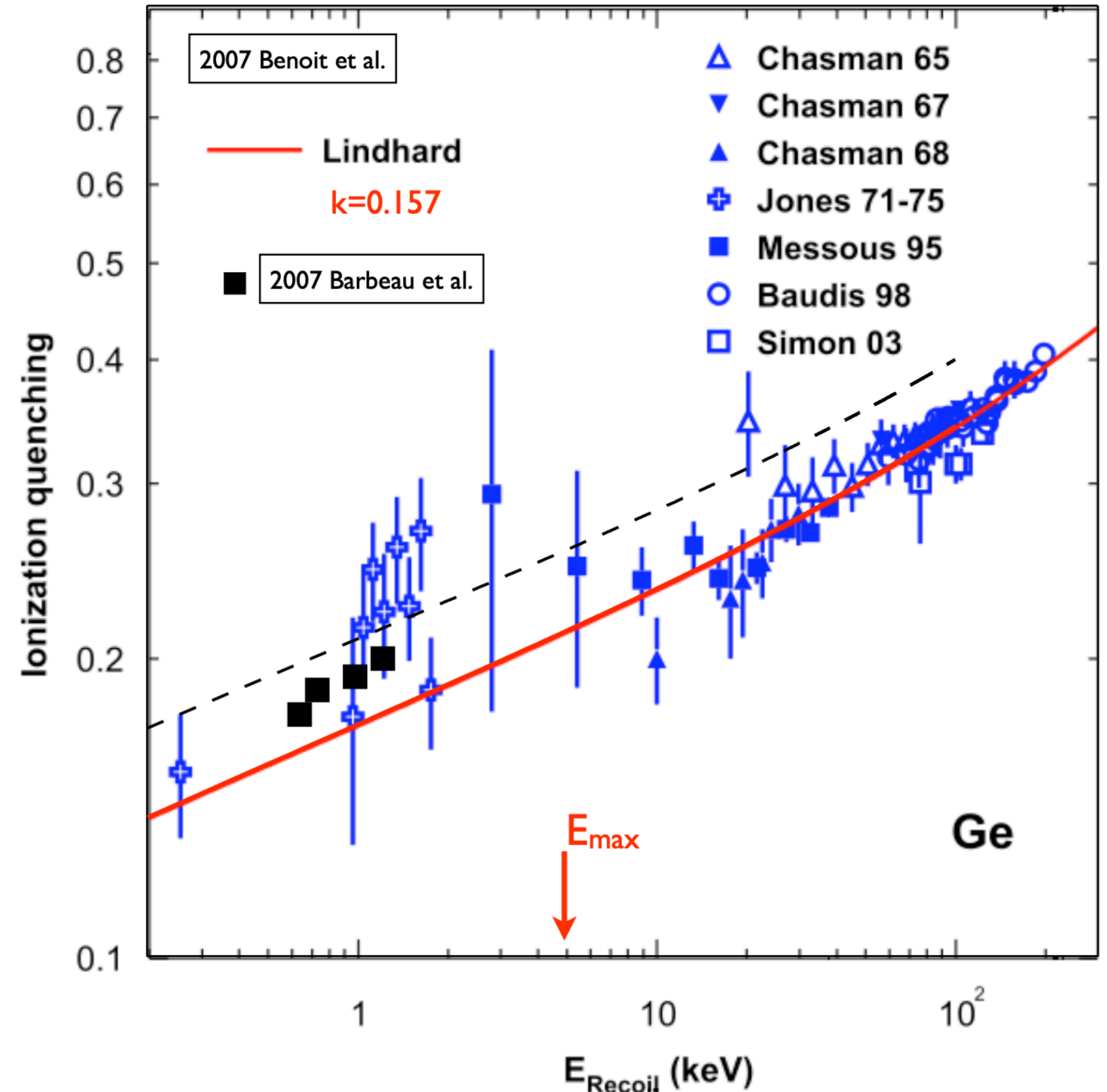

# And energy loss: quenching

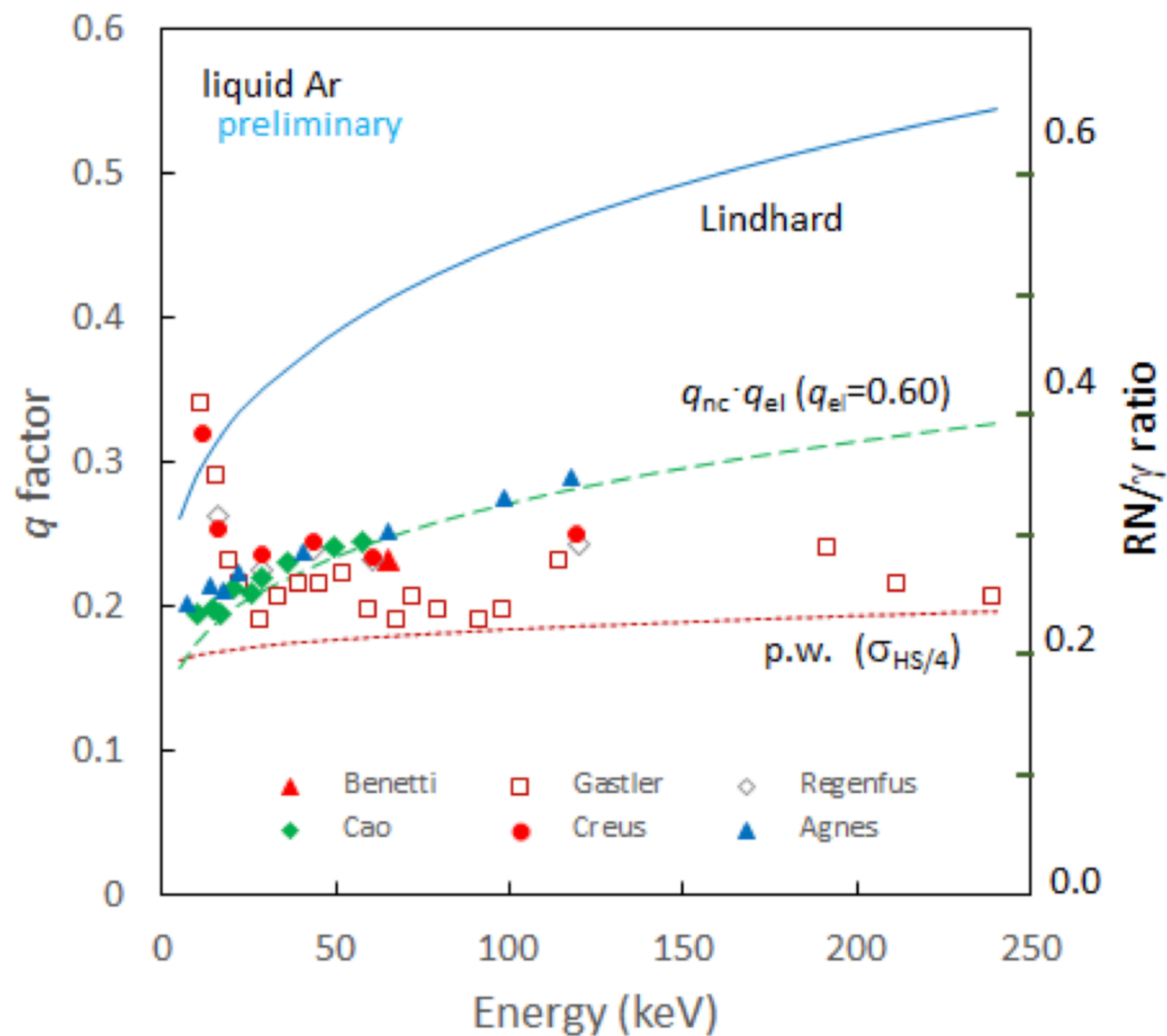

Credit: A. Hitachi. A. Mozumder, arXiv:1903.05815, 2019

- In noble elements this has never really worked out for the prediction
- The values are always lower than they “should be”
- This has been attributed to either electronic quenching or electrons escaping

# And energy loss: quenching

- More recently the measurements (and derivation) have been done slightly differently with closer results
- Essentially use both scintillation and ionization signals to reconstruct the nuclear recoil energy

$$E_{ER} = W(N_{ph} + N_q)$$

$$E_{NR} = W(N_{ph} + N_e) \cdot \frac{1}{f_n}$$

$$f_n = \frac{W(N_{ph} + N_e)}{E_{NR}}$$

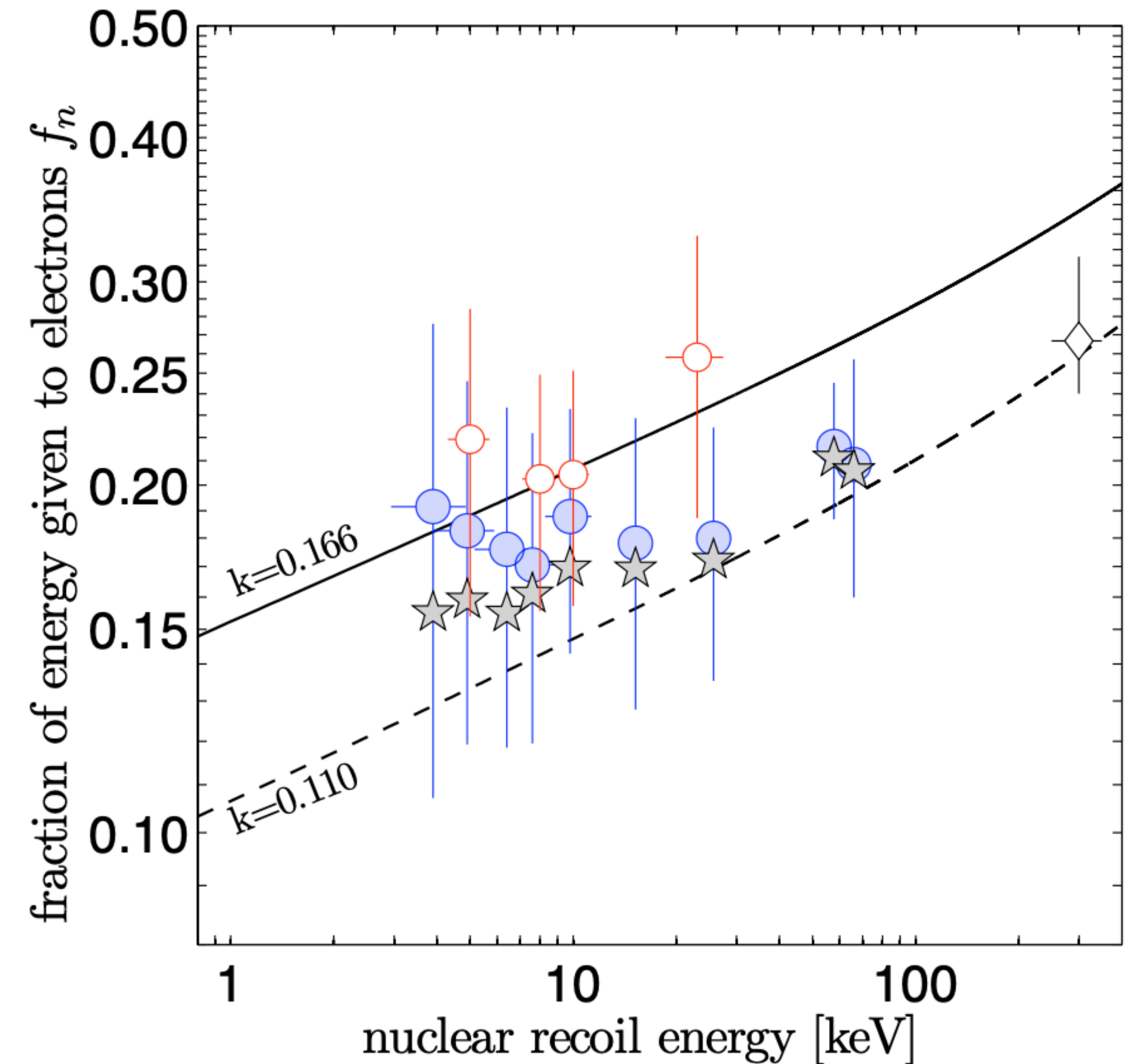

Credit: Sorensen, Dahl, Phys. Rev. D 83, 063501



# Expectations

- To interpret our data properly, we'll need to know how much light to expect from both of these interactions
- There are two ways to do this: measurement and simulation
- For the measurement, we'll need to know how much energy is actually deposited into the nucleus
- That's not simple, but can be done using tagged mono-energetic neutron sources



# Expectations

P. Agnes et al., Phys. Rev. D 104, 2021

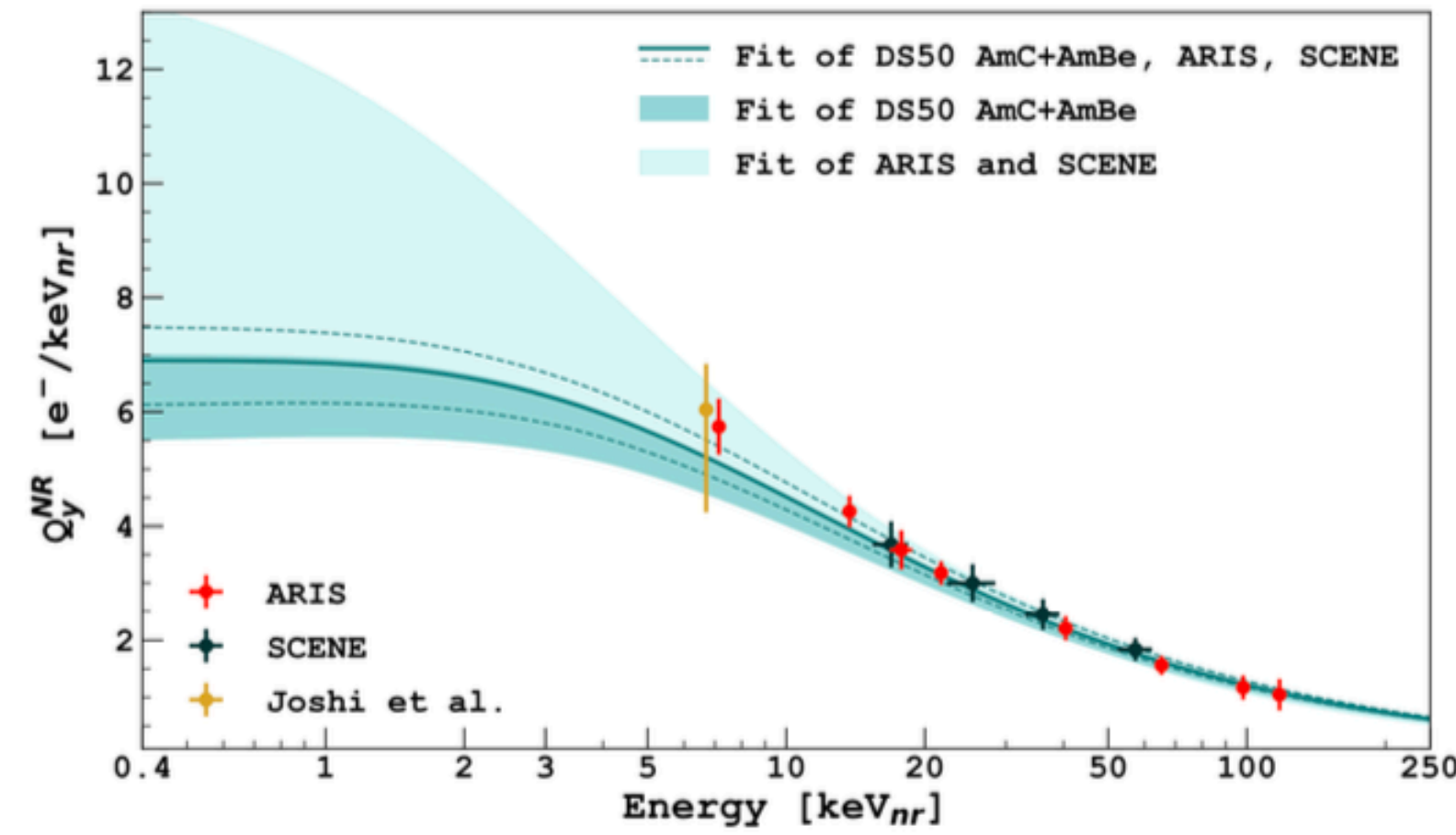

- LAr: charge yield measured down to  $\sim 0.5 \text{ keV}_{NR}$  ( $\equiv 3$  ionisation electrons)

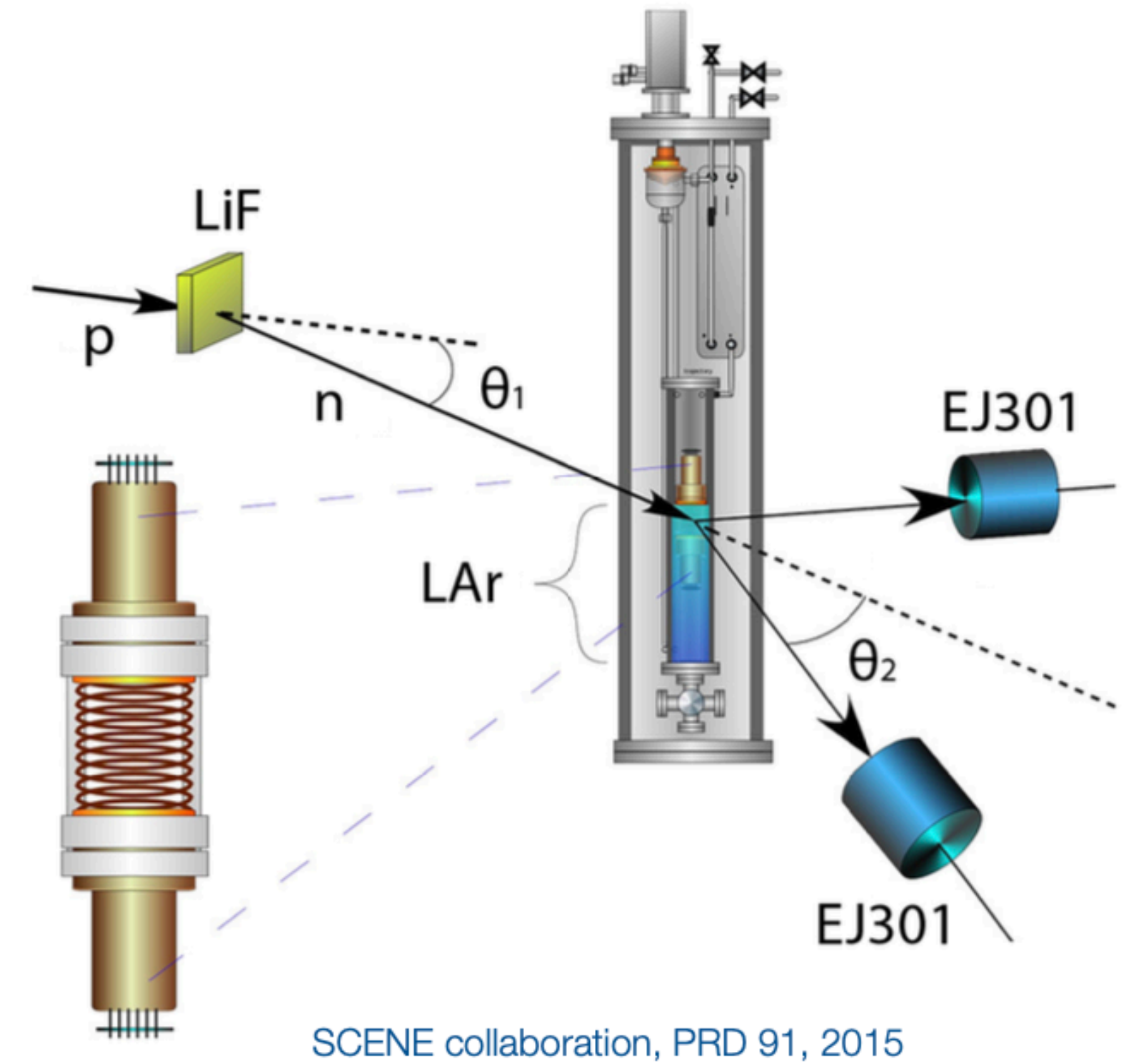

SCENE collaboration, PRD 91, 2015

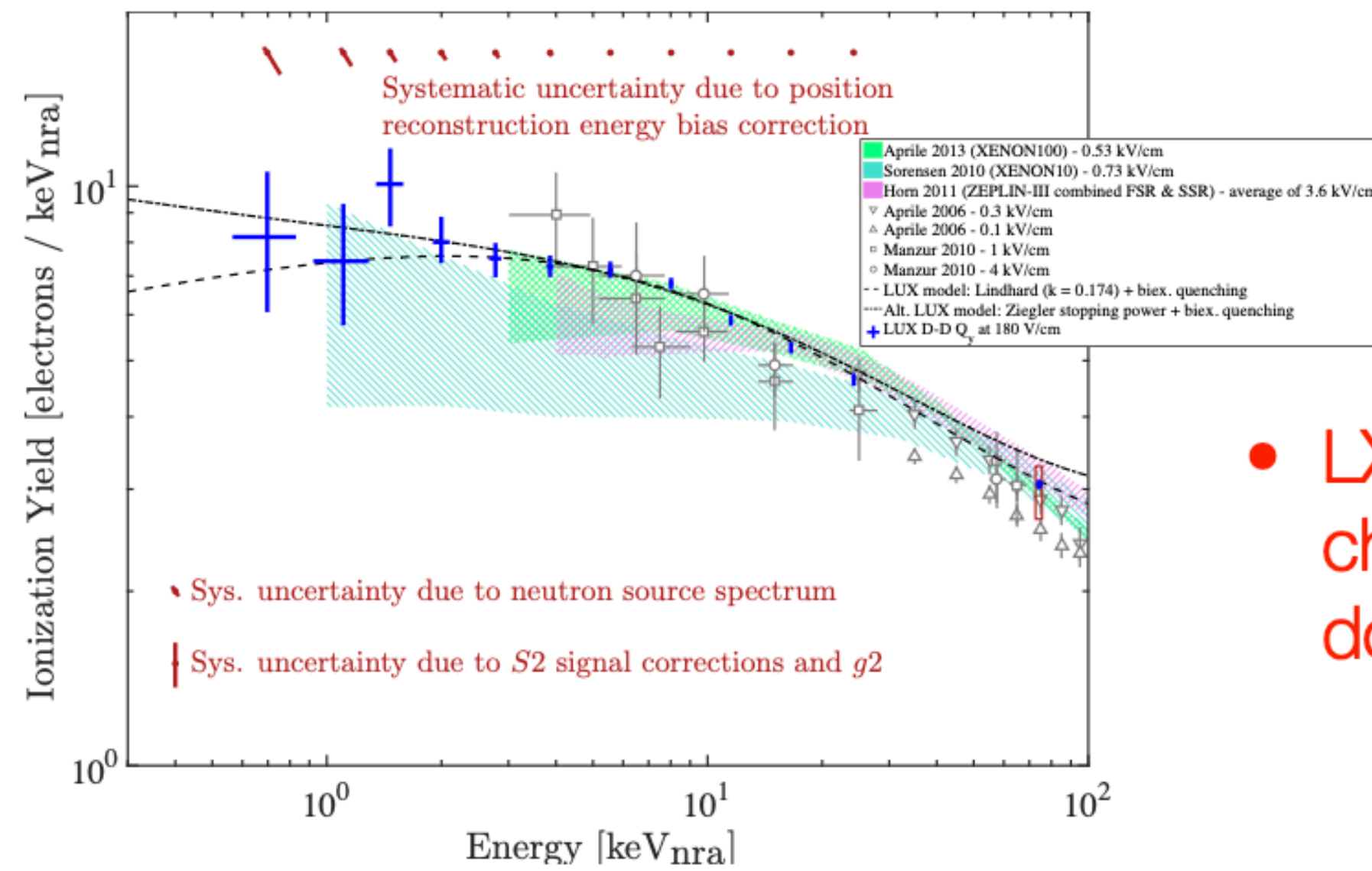

- LXe: here data from LUX; charge yield measured down to  $0.7 \text{ keV}_{NR}$

Slide from L.Baudis, GRIDS 2024



# Expectations

- The other way to do this is with simulations
- Most prevalent use is of NEST (Noble Element Simulation Technique) which allows for the parametrization of all of the interactions we've been discussing
- Uses semi-empirical models to produce light in specific detector geometries
- Results are validated against data when it is available
- See more at <https://nest.physics.ucdavis.edu>



# Simulations from NEST — Xenon

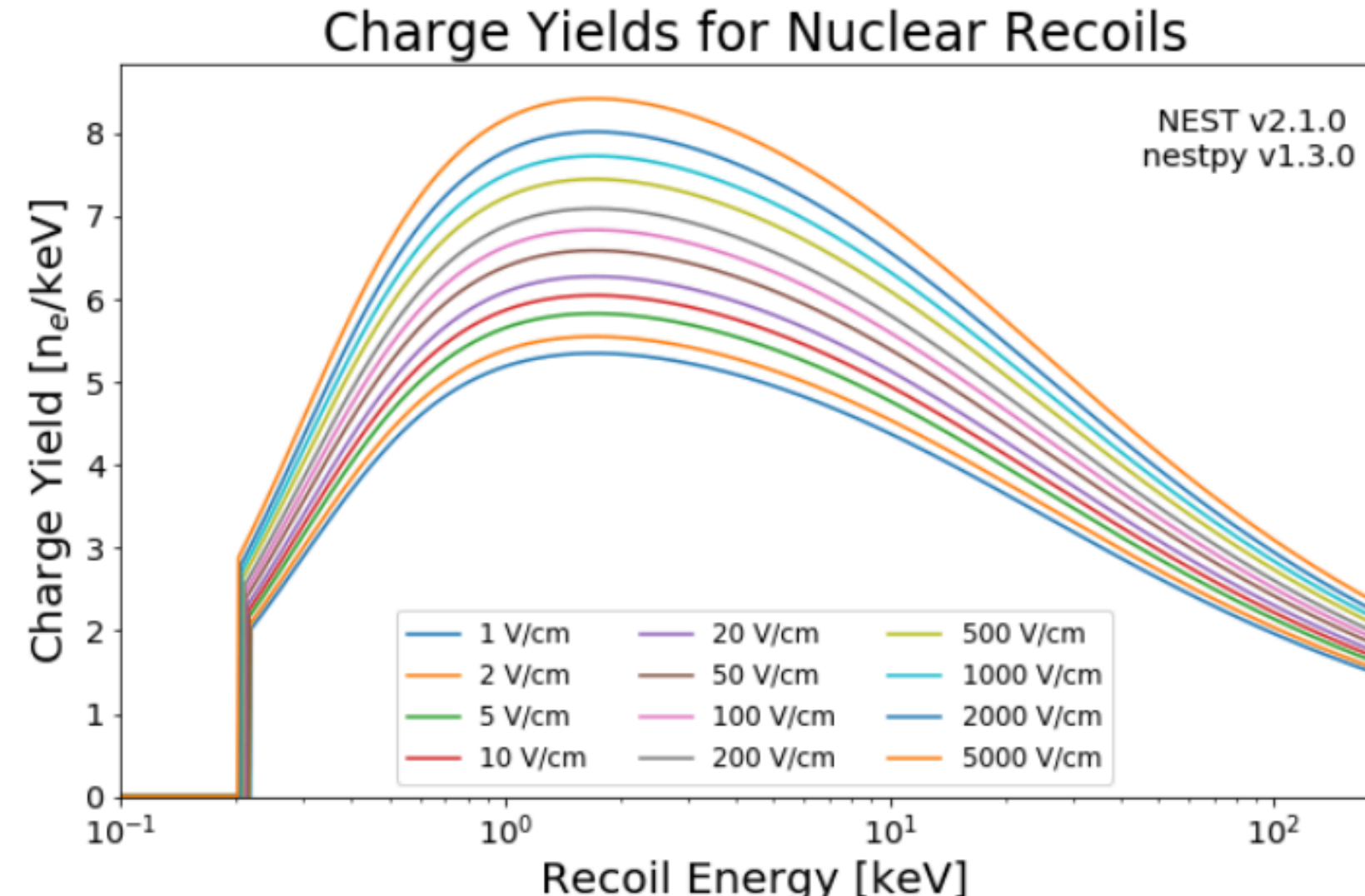
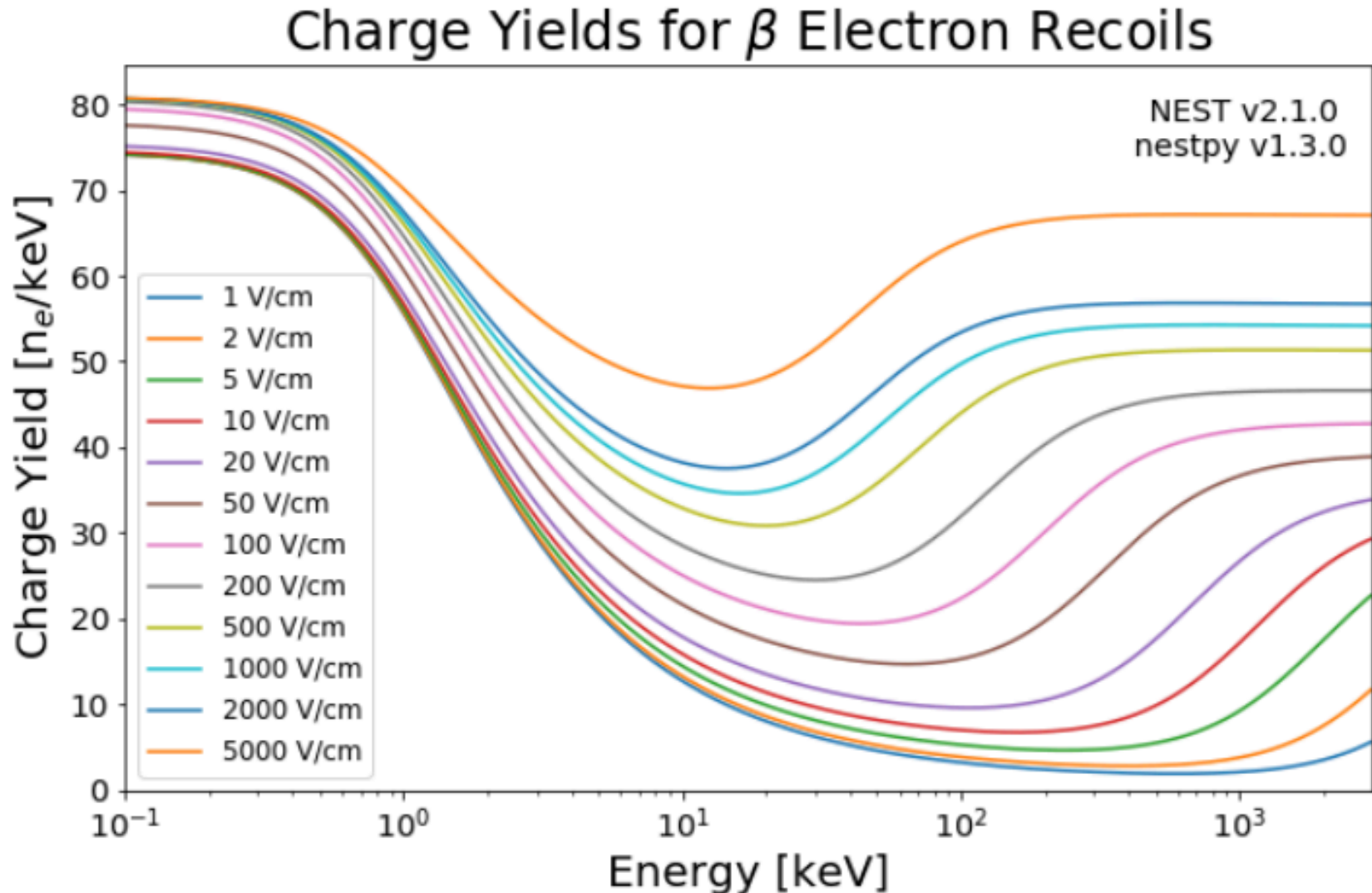
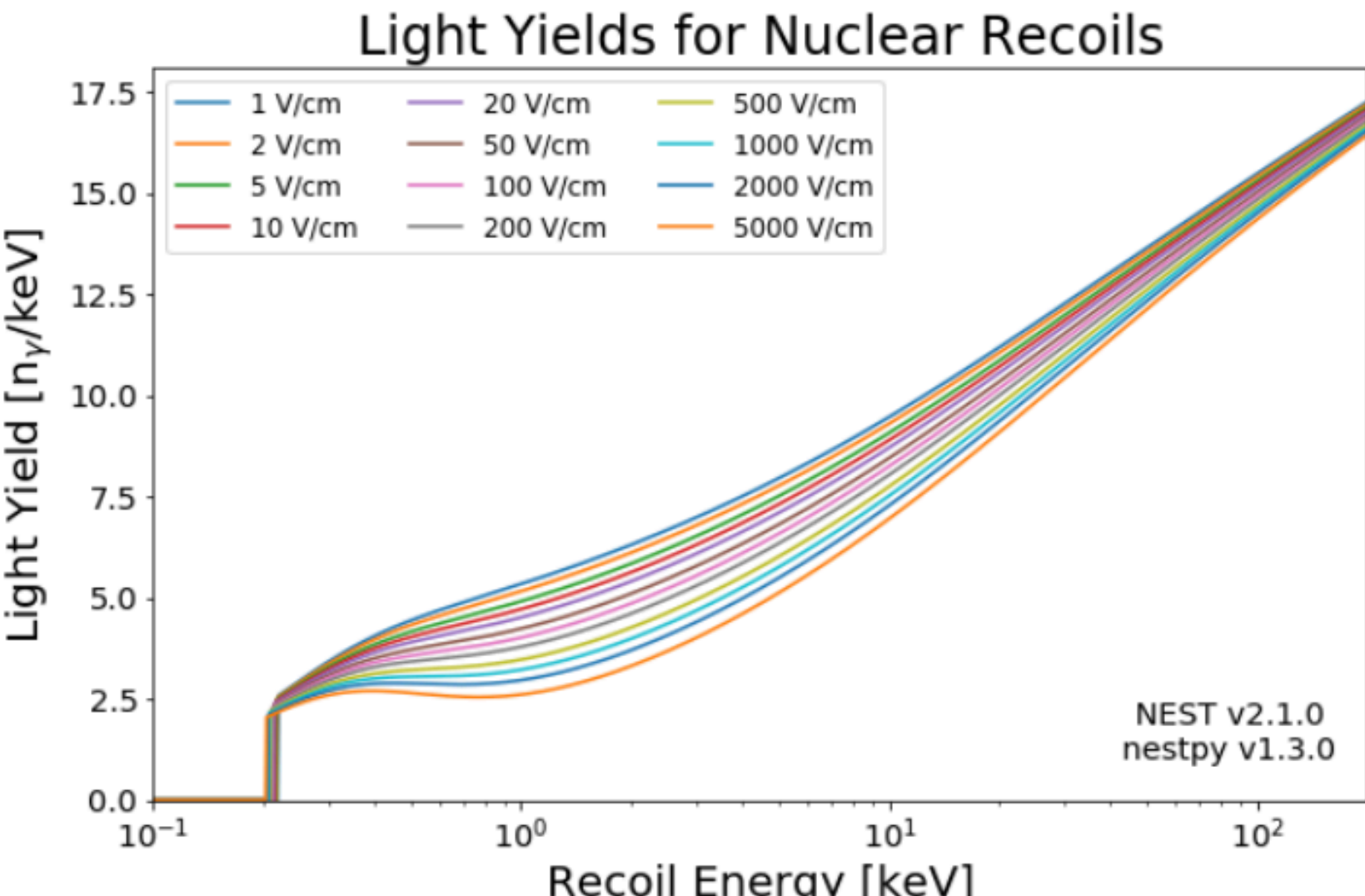
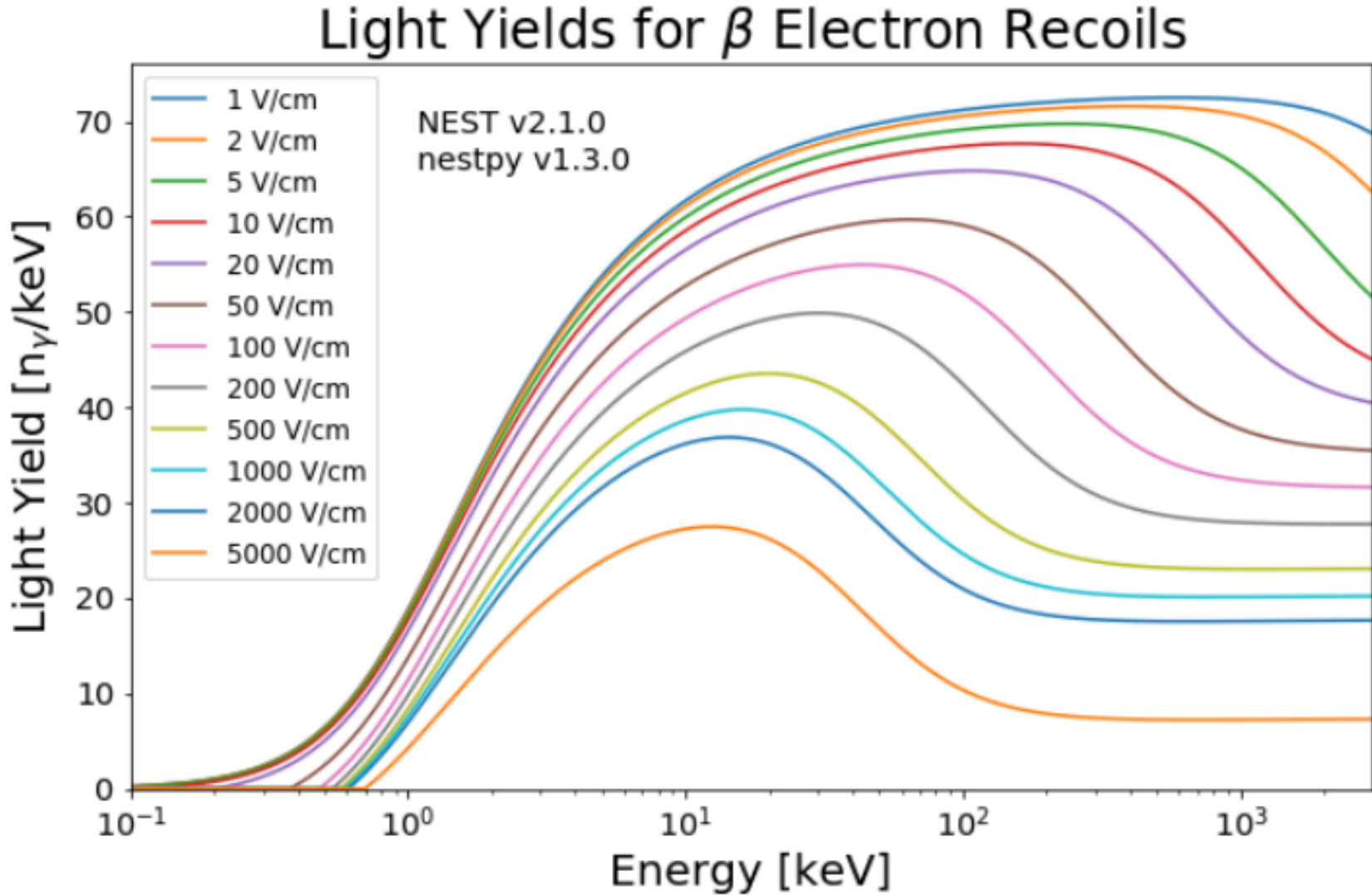

# Simulations from NEST — Argon

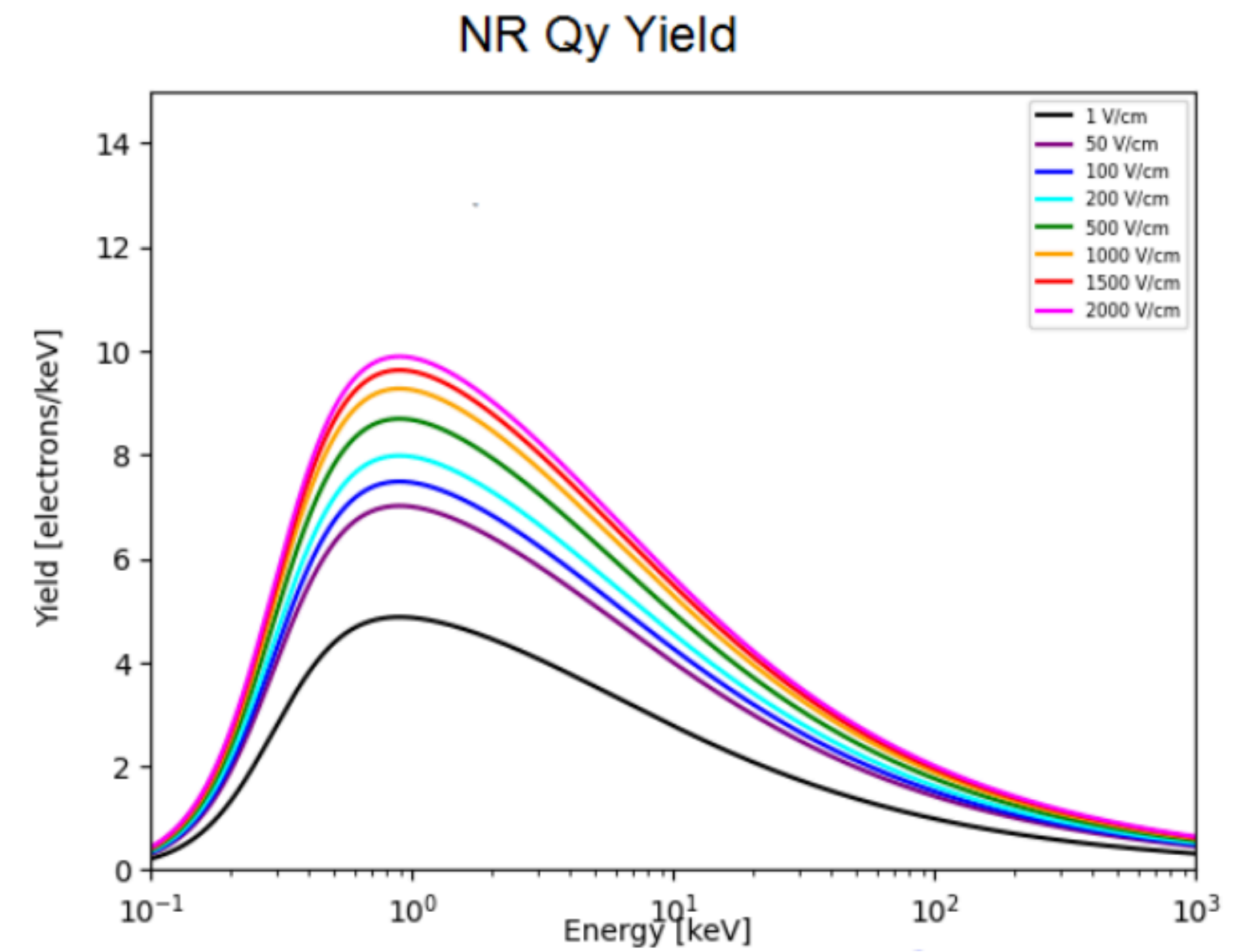
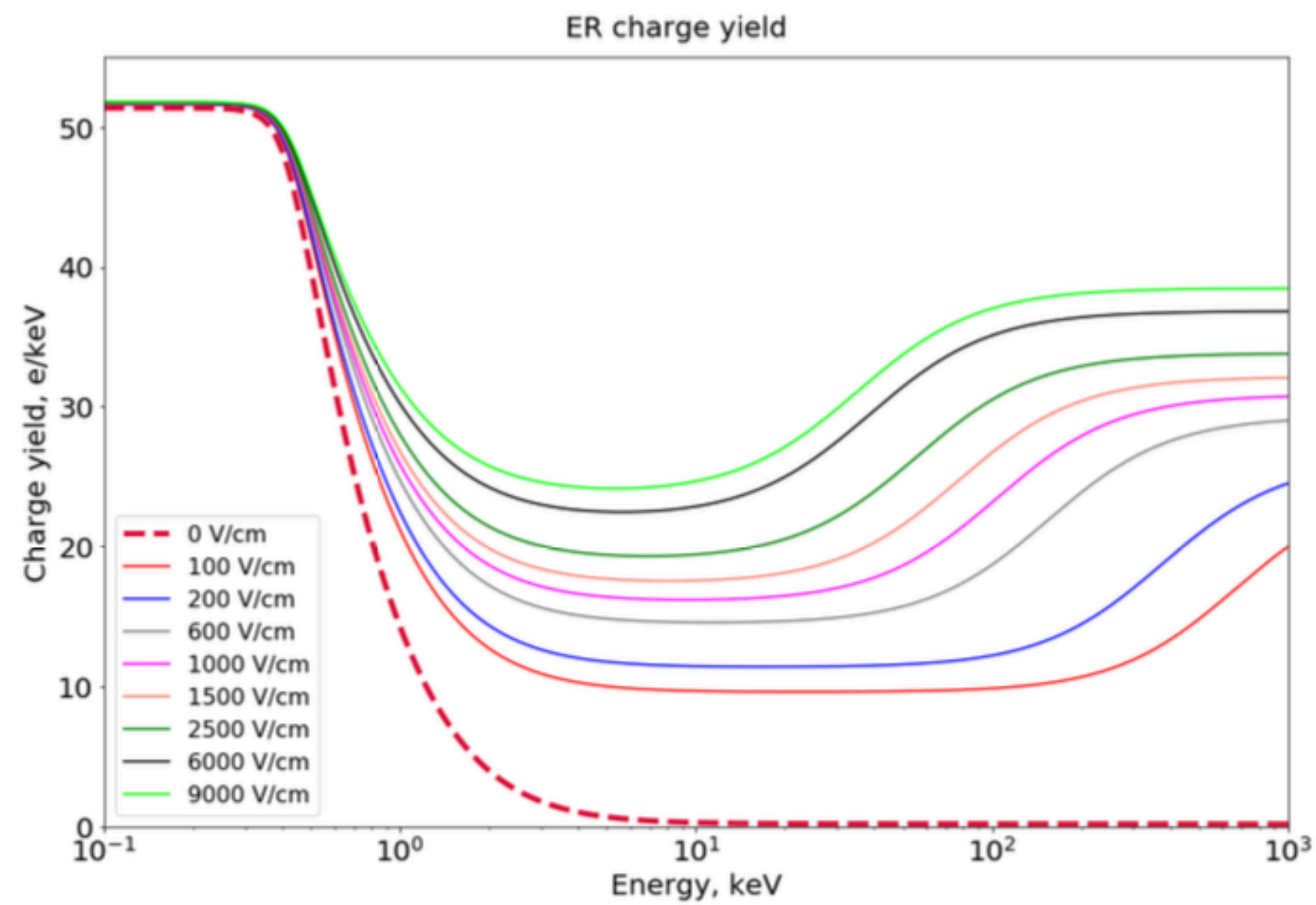
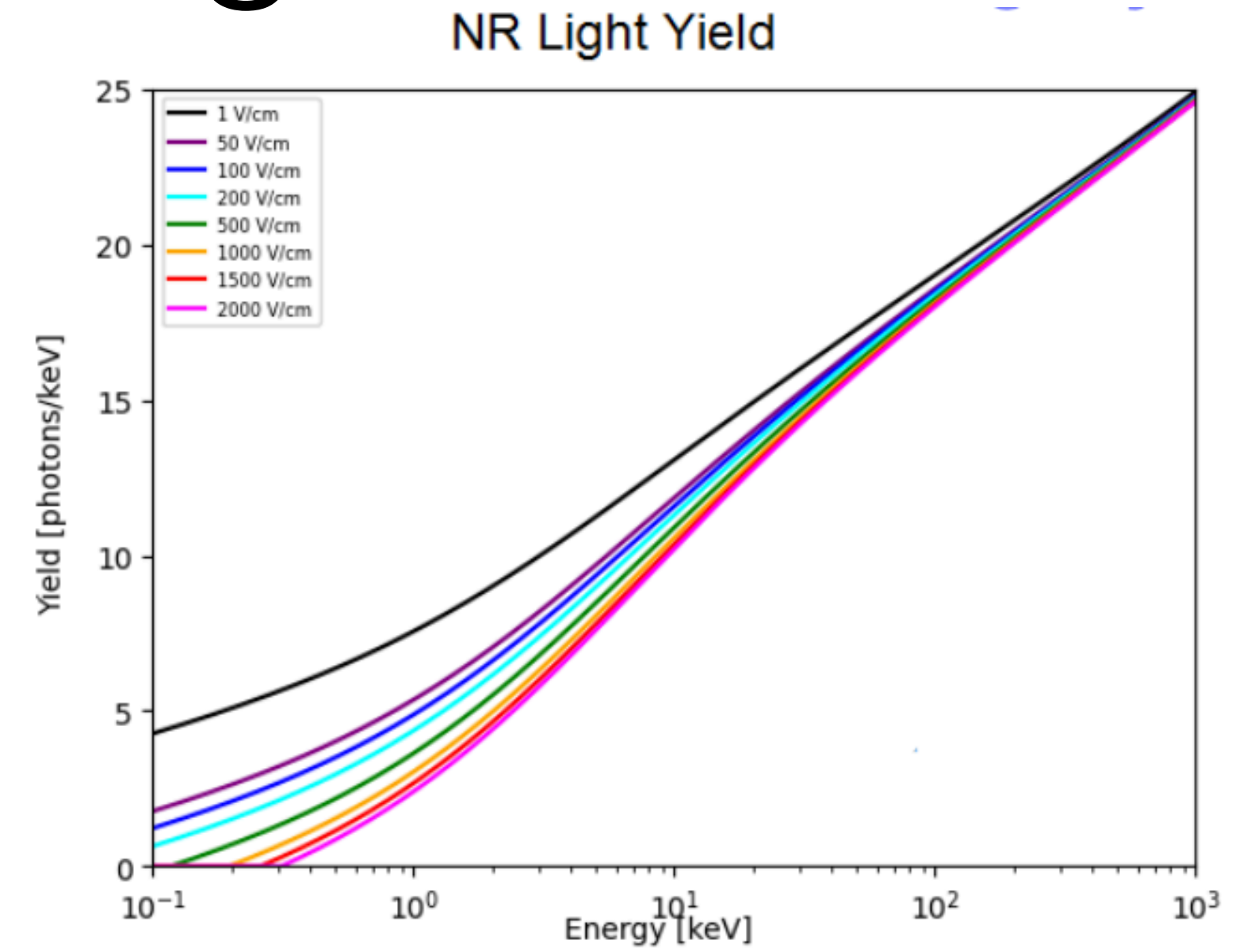
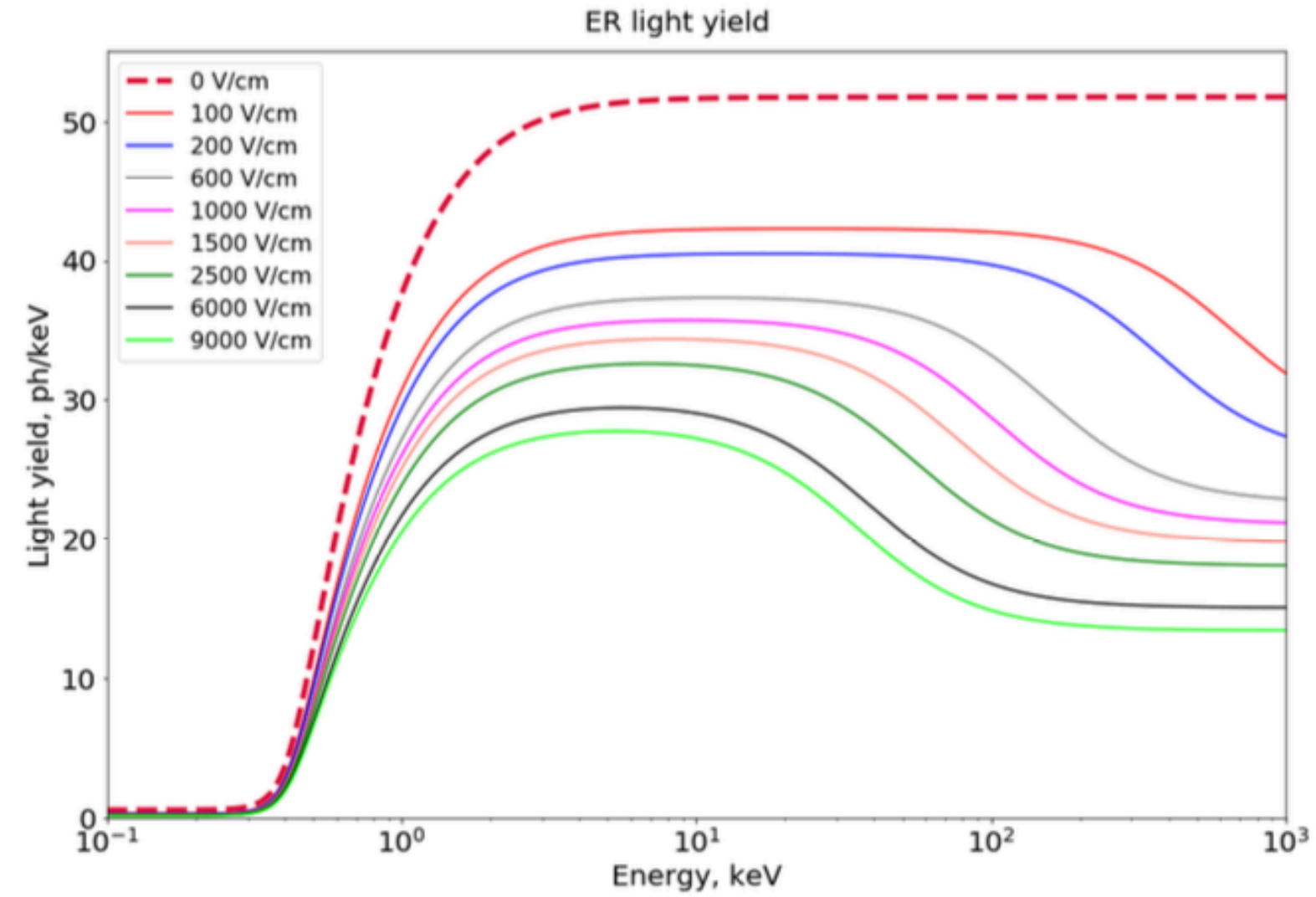

# Summary of NEST results — Xenon

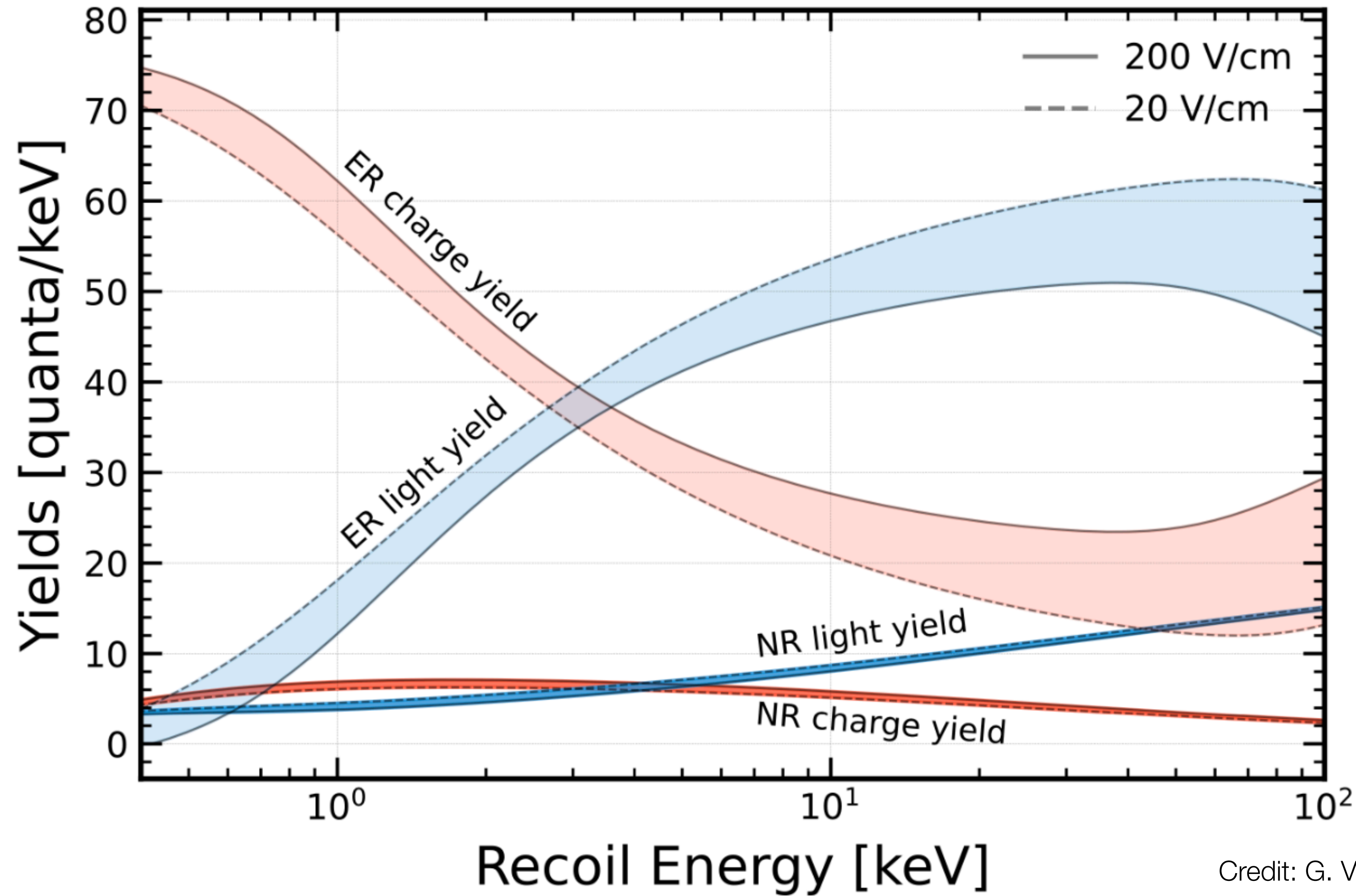

Credit: G. Volta



# Charge Collection

- As we said before, we can use an electric field to extract the electrons that are produced in ionization
- This does stop recombination, and also gives information about the interaction itself
- But are there any potential challenges with this?

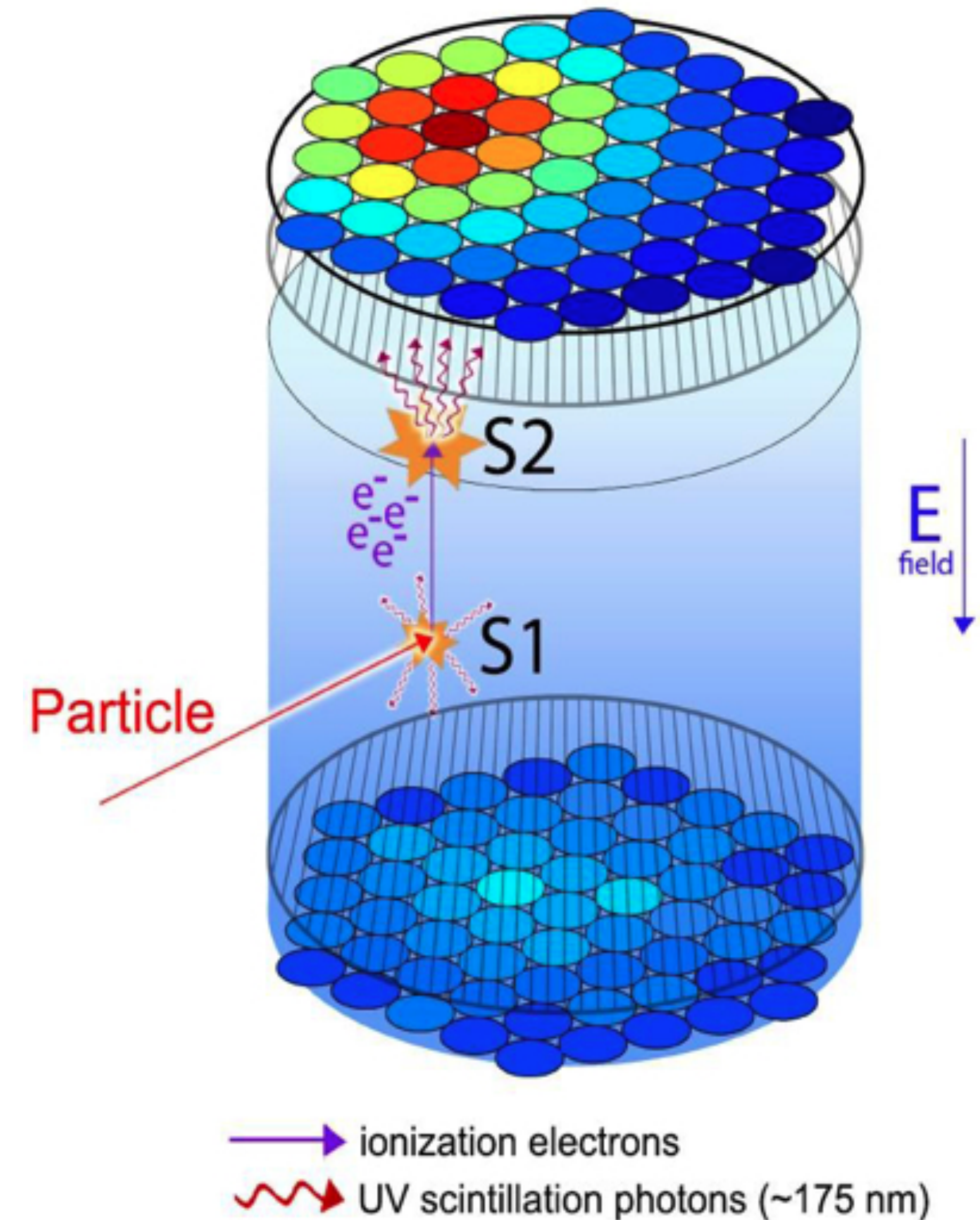

Credit: CH Faham (Brown)

# Exercise: TPC electric fields

- Design your dual-phase TPC!
- Kind-of: just determine the potential at which the cathode, anode, extraction grid should be for your experiment



# Exercise: TPC electric fields

- Design your dual-phase TPC!
- Kind-of: just determine the potential at which the cathode, anode, extraction grid should be for your experiment
- Some numbers to start playing with, but be creative!

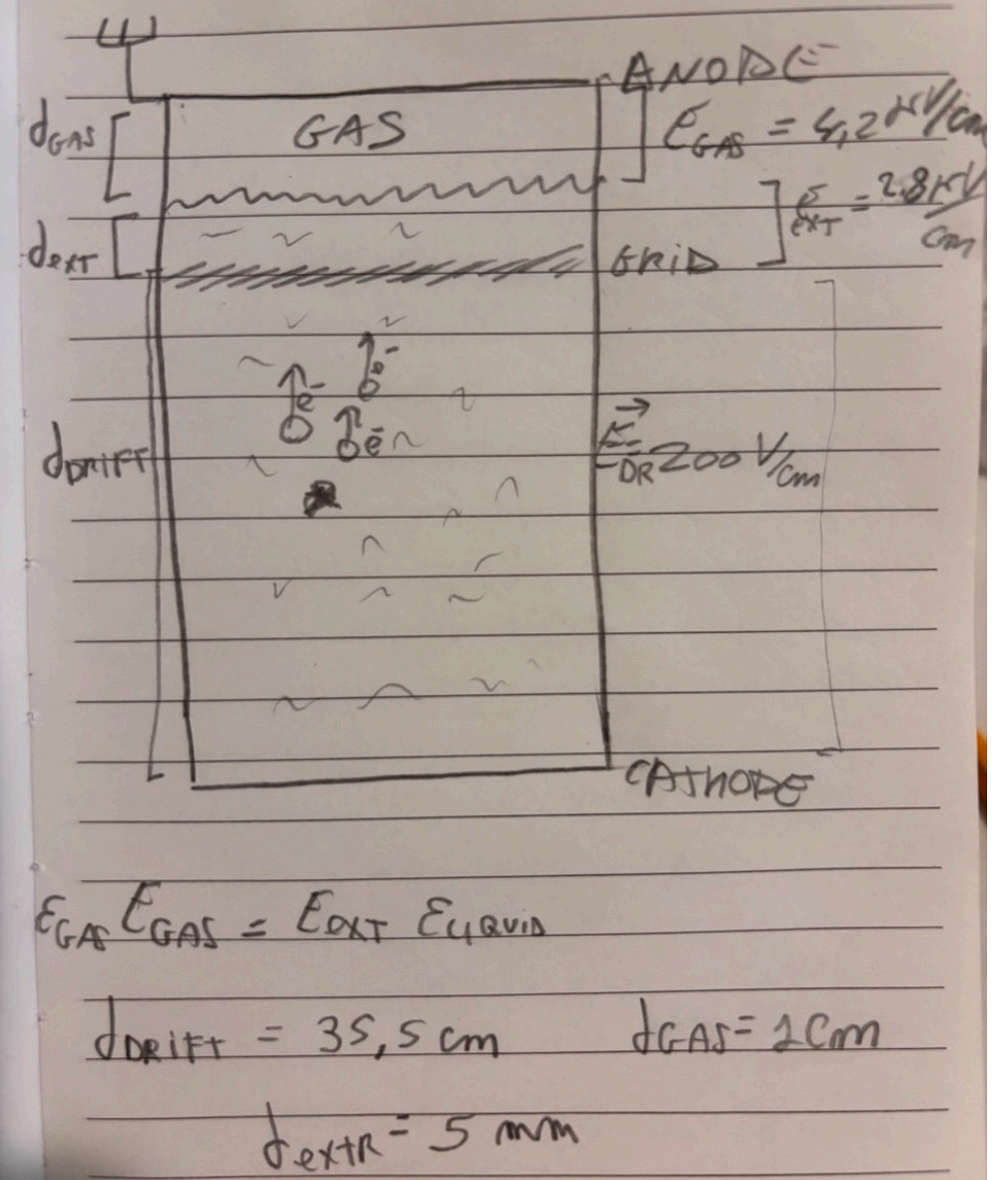

# Charge Collection - Issues

- The biggest issue is the purity of the material itself
- Any contaminants (especially oxygen) in the fluid can absorb the electrons during their drifting
- The ability to move the electrons is called the “electron lifetime” and is defined as you would expect

$$N_e(t) = N_e(t_0)e^{-t/\tau}$$

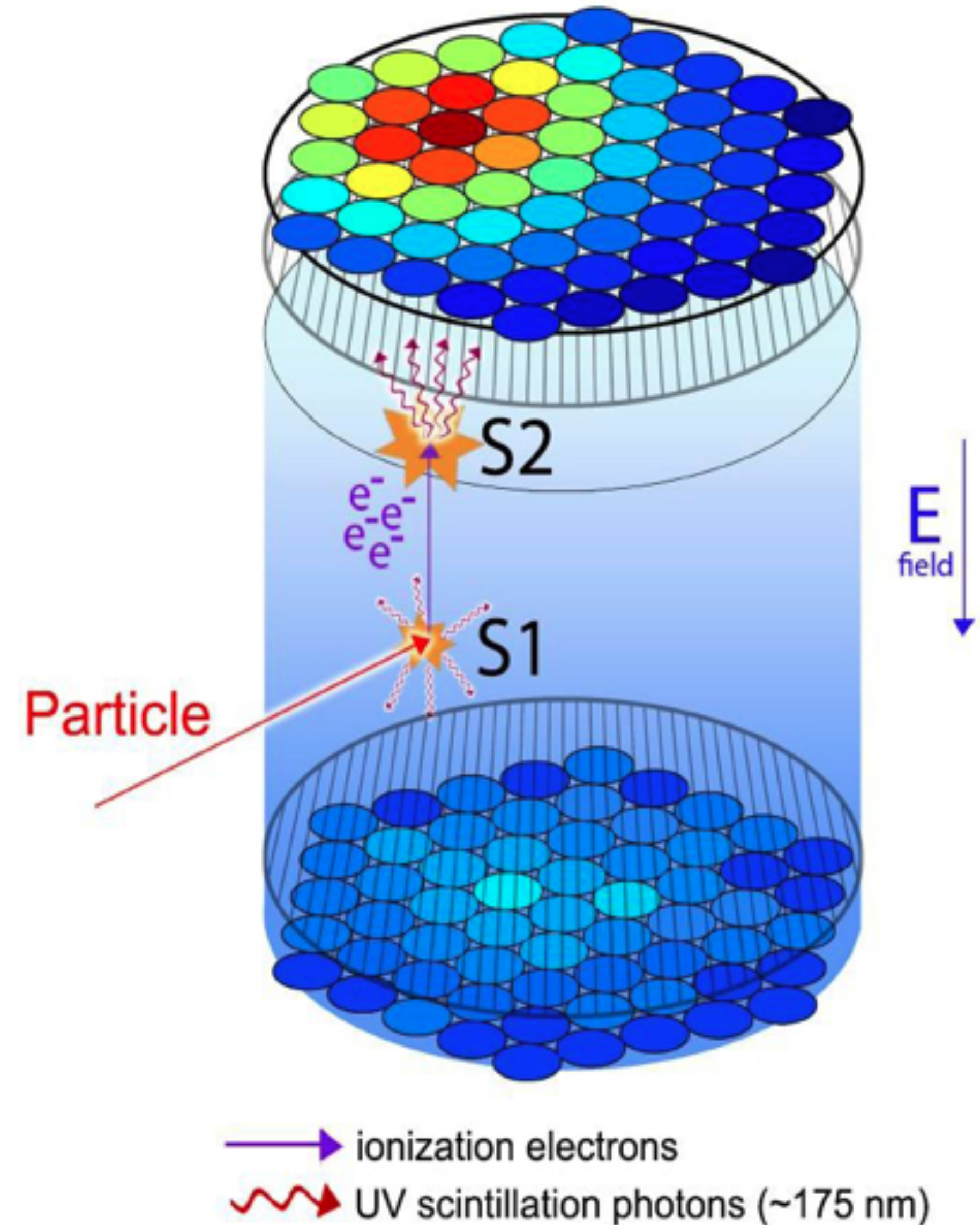

Credit: CH Faham (Brown)



# Charge Collection - Issues

$$N_e(t) = N_e(t_0)e^{-t/\tau_e}$$

The electron lifetime  $\tau_e$  is related to the concentrations of impurities

$$\tau_e = \frac{1}{\sum_i k_i C_i} = \frac{1}{k_{O_2} C_{O_2}}$$

Where oxygen dominates the contaminants

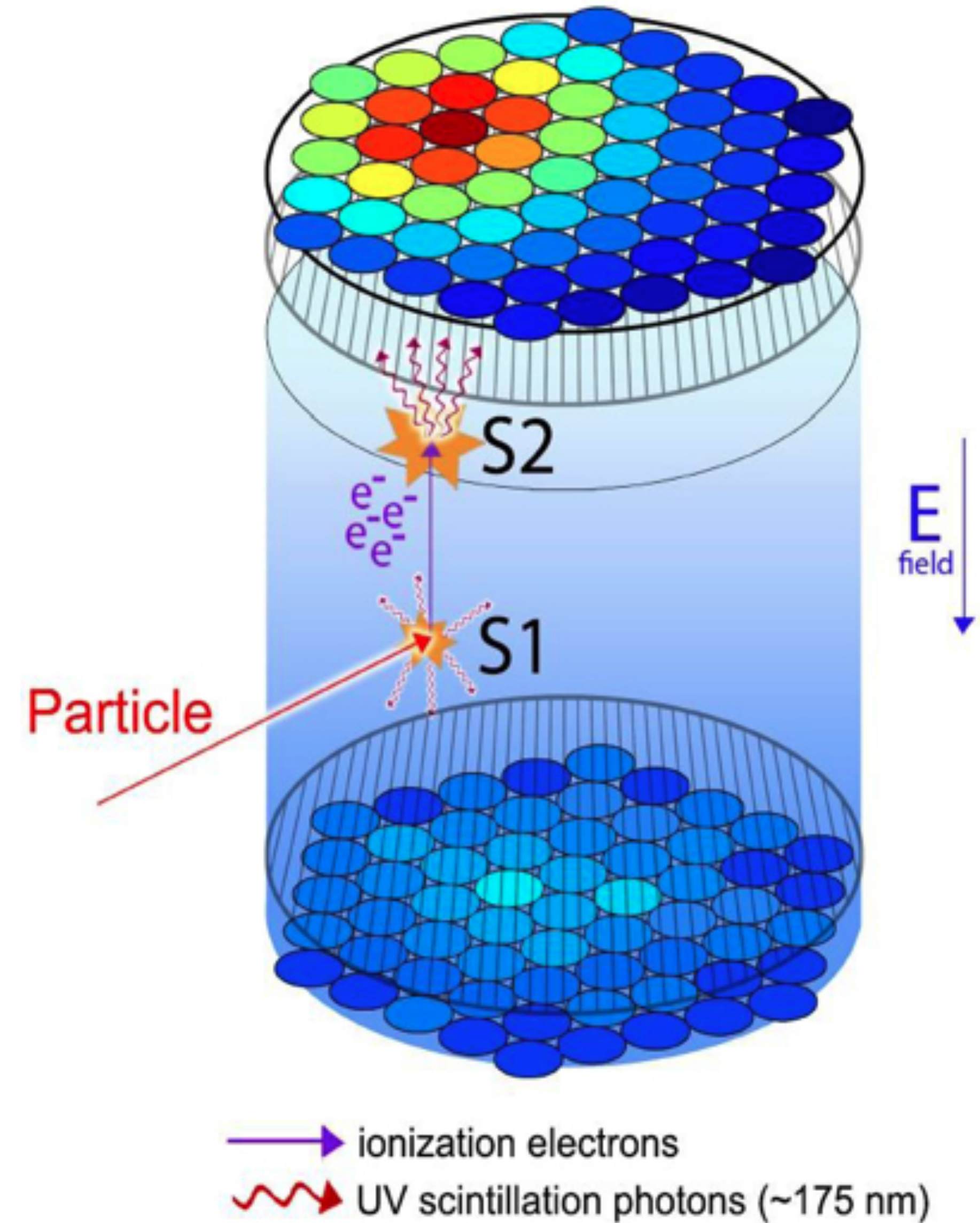

Credit: CH Faham (Brown)



# Charge Collection - Issues

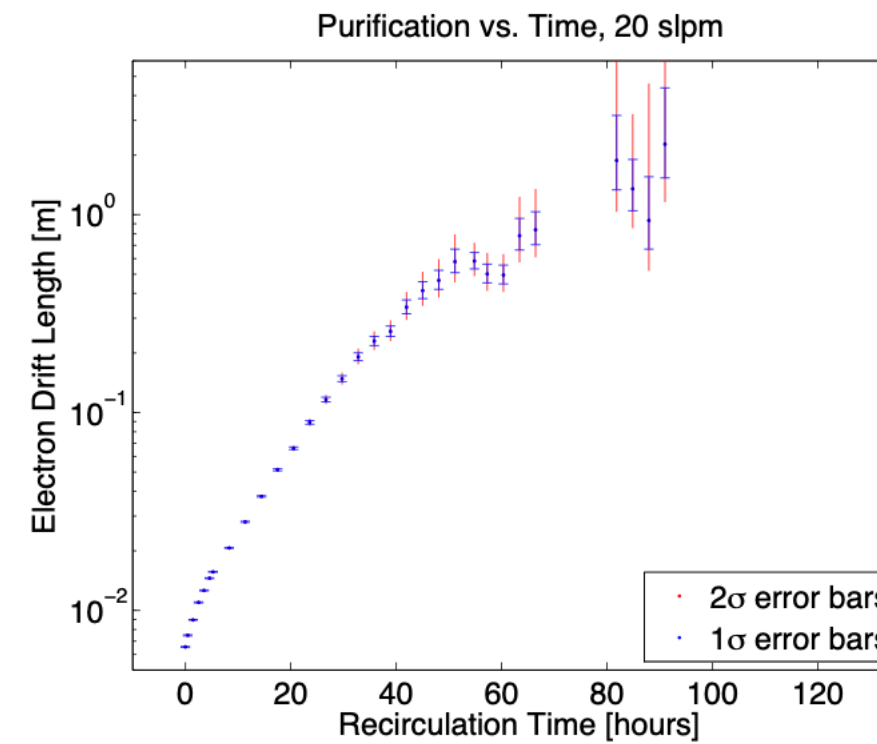
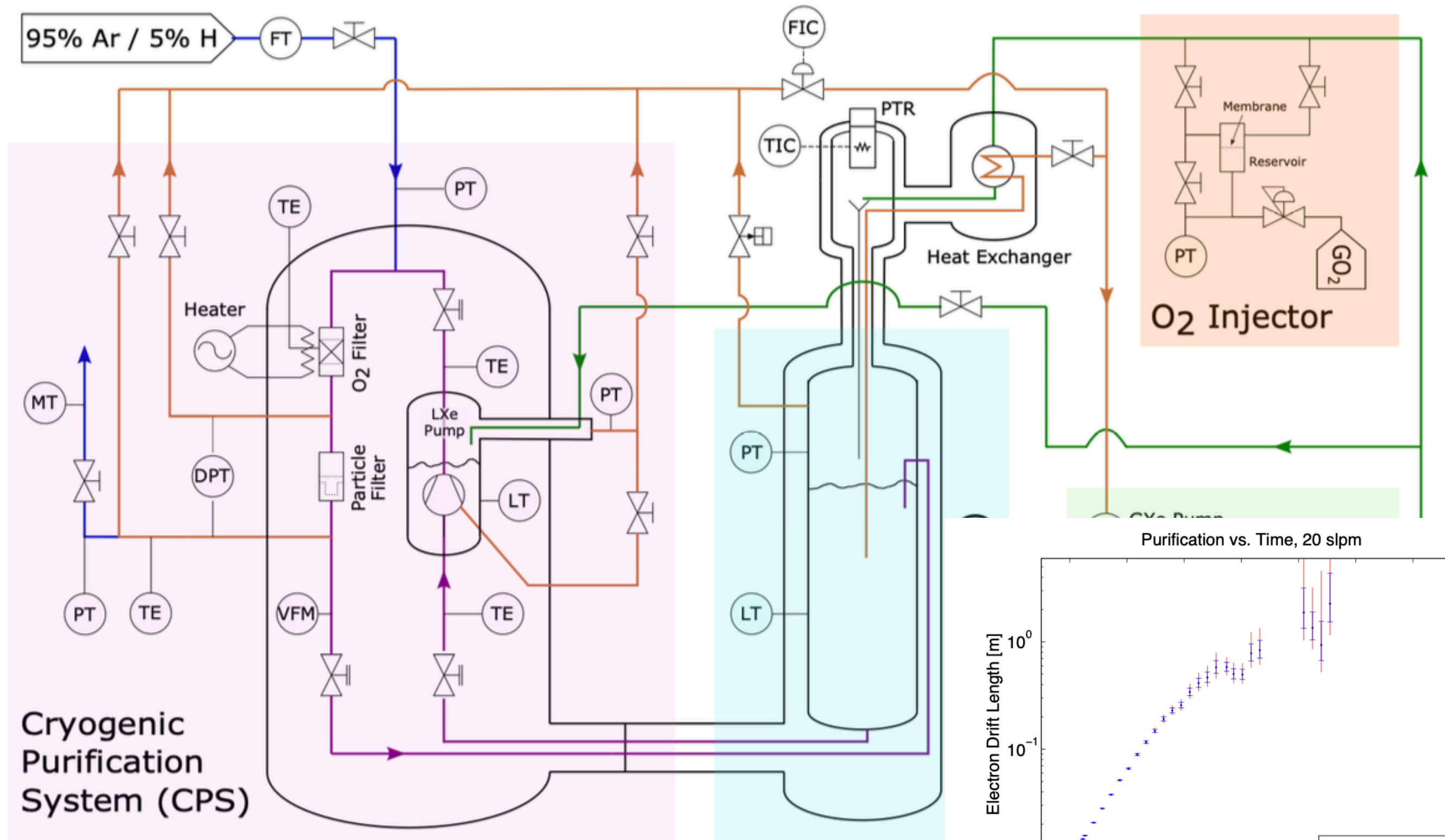

- To beat this, constant purification is obviously necessary
- It has to be done pretty much constantly, since new junk is coming out of the detector all the time
- It's also only done in the gas phase, leading to an energy problem
- Oxygen needs to be in ppb range



# Properties - Inertness



- Noble elements are very unreactive, it's kind of their thing
- This means they are first and foremost stable
- The complete outer electron shell also means they are very unlikely to participate in any reactions
- This can make purification very easy, even to the ppb level or below
- Generally something reactive like zirconium is included in a porous form to achieve this



# Charge Collection - Issues

- The results of the purification are clear when running
- The drift length is increased significantly while the contaminants are removed
- Once turned off, the drift length decreases just as quickly...

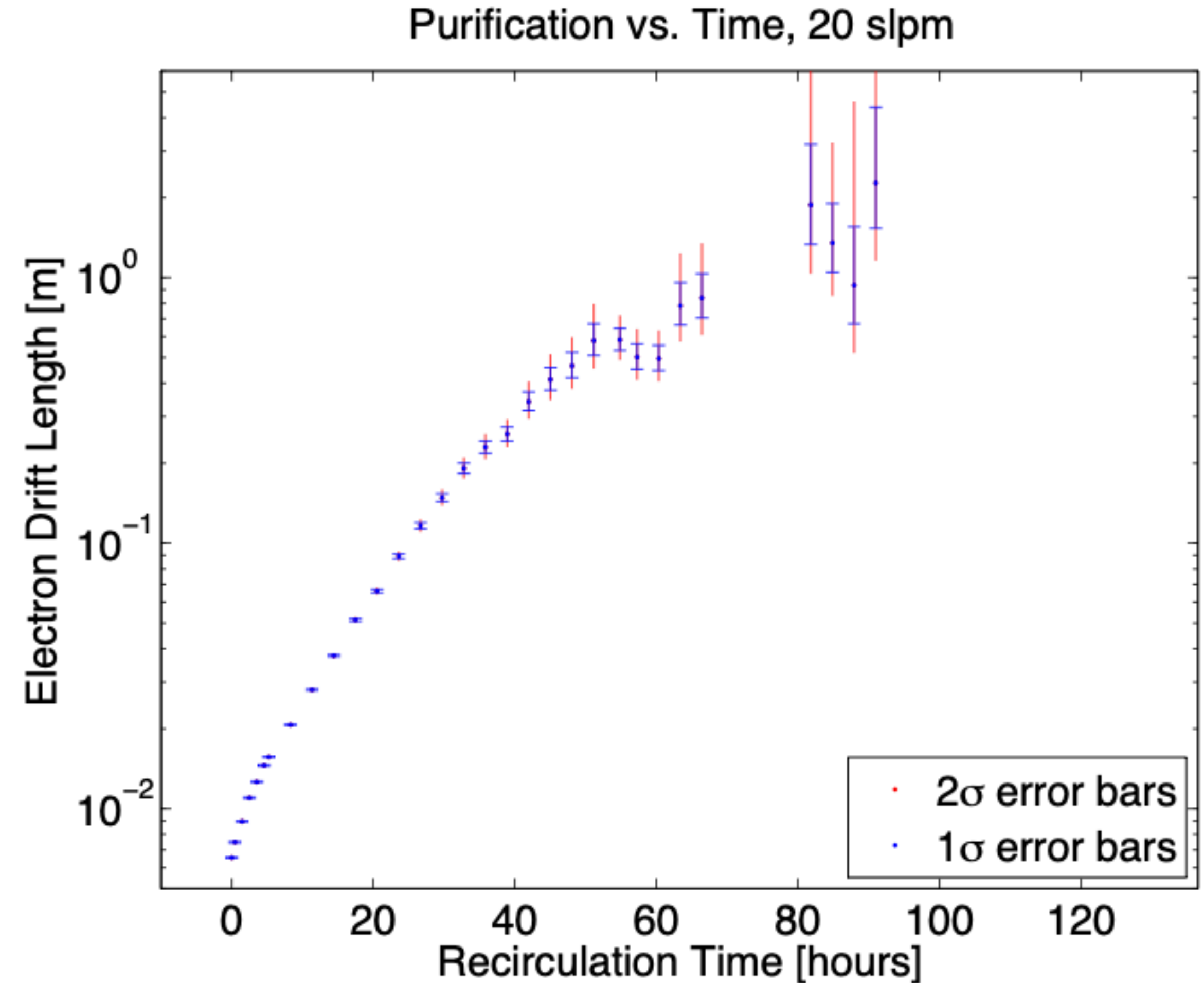

Credit: K.Clark, for LUX



# Radon removal

Atom	Atomic Diameter [Å]
Ar	3.8
Rn	4.16
Xe	4.10

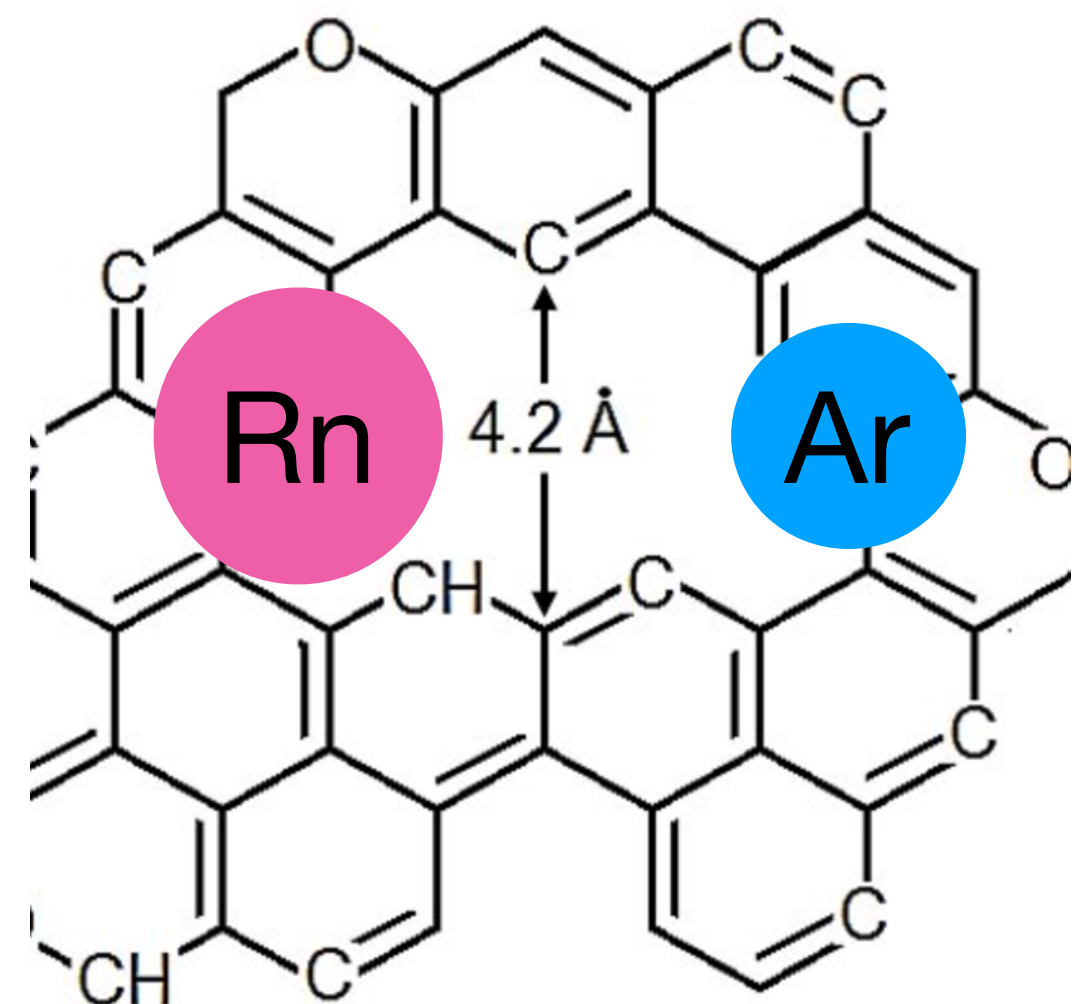

- 222-Radon and its daughters can deposit on inner detector materials, releasing alphas and beta particles
- Activated charcoal in a gas recirculation system can selectively remove radon from argon, but non from xenon

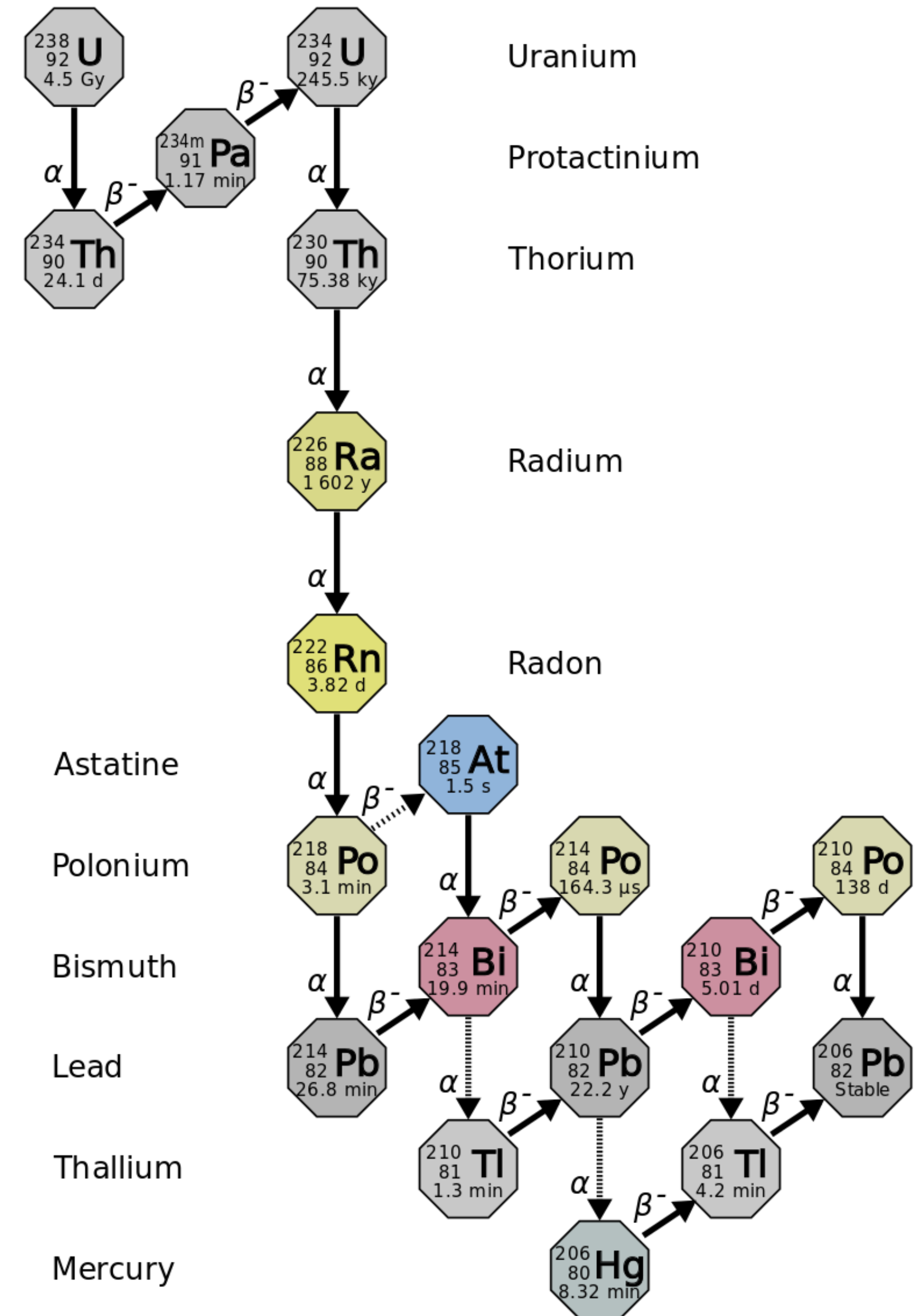

# Radon removal

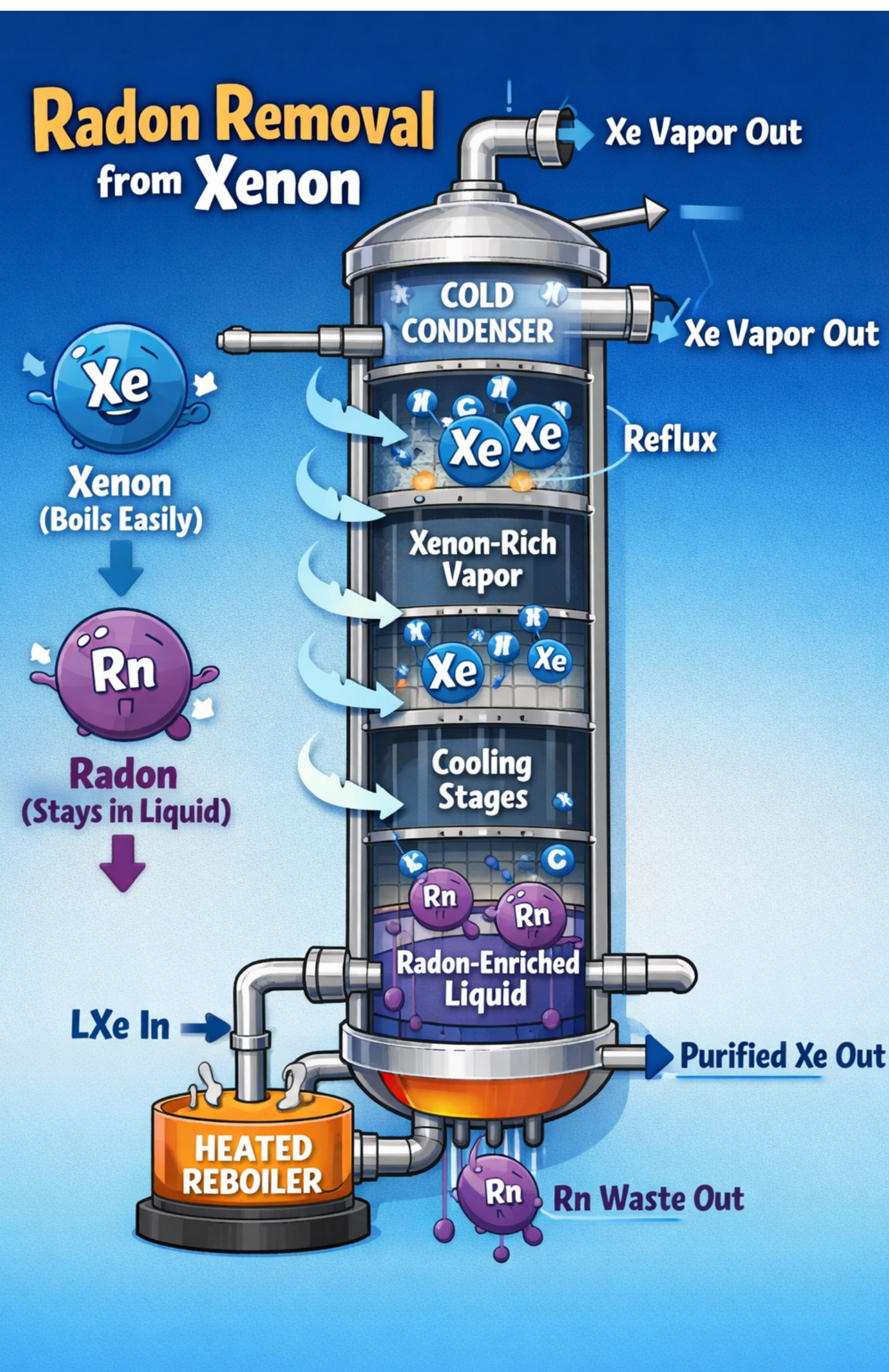

- 222-Radon and its daughters can deposit on inner detector materials, releasing alphas and beta particles
- For a xenon system, you will need to use a cryogenic distillation column

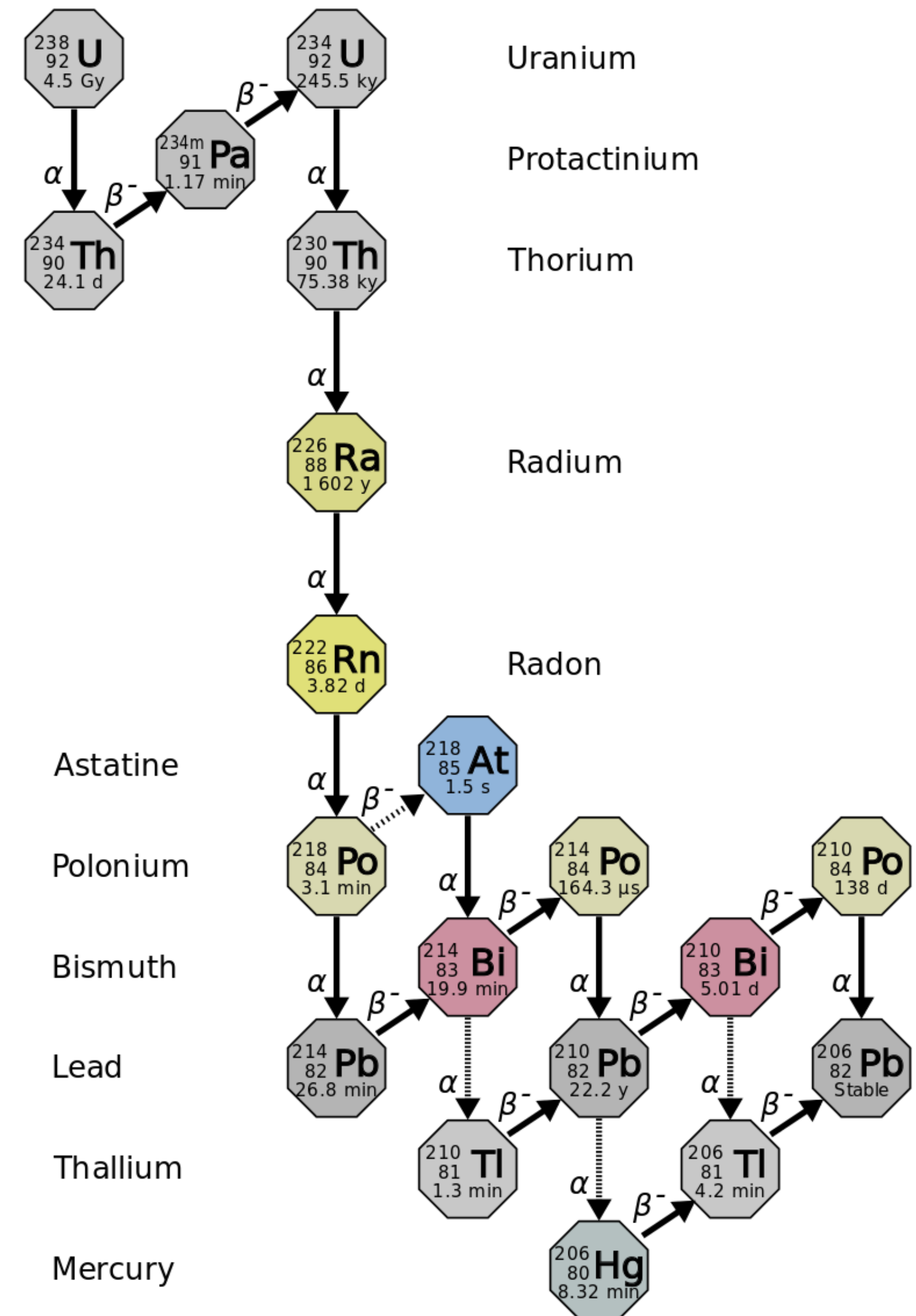

# Radon removal

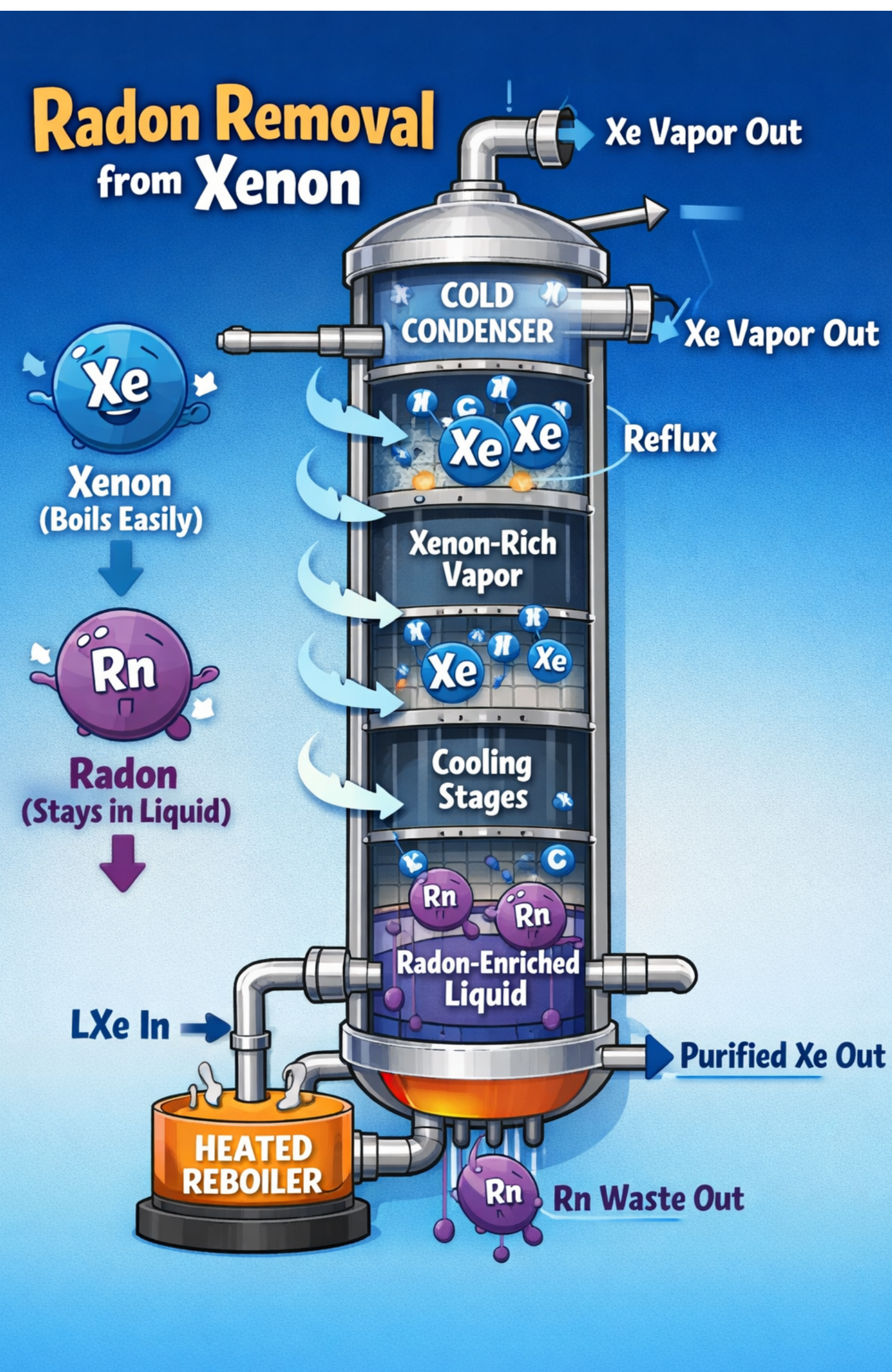

- 222-Radon and its daughters can deposit on inner detector materials, releasing alphas and beta particles
- For a xenon system, you will need to use a cryogenic distillation column

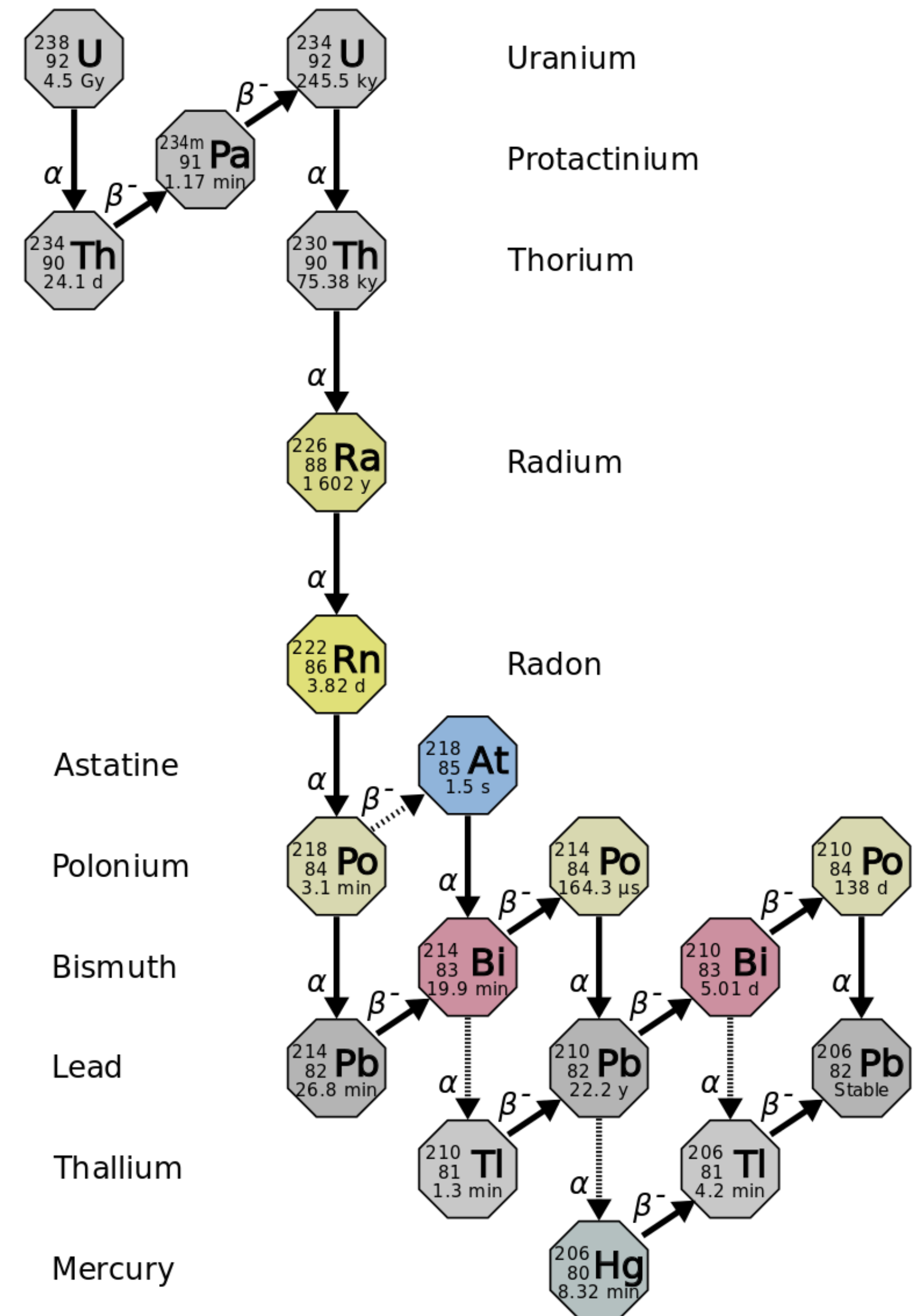

- AI-made cartoon: it's way more scary

# Detectors

- I'm supposed to be talking about detectors, so let's do that
- What do we want our detector to do?

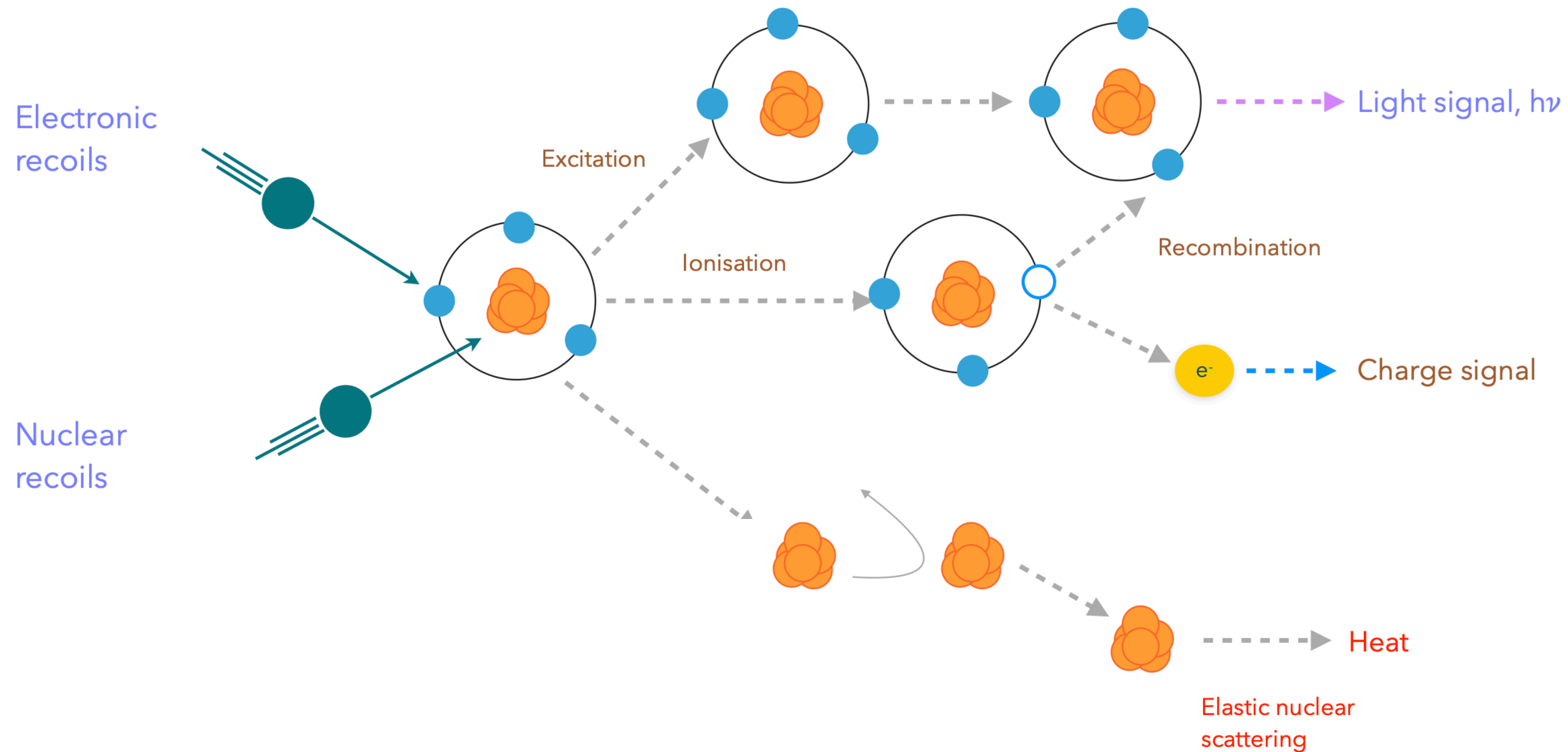

# Detectors

- I'm supposed to be talking about detectors, so let's do that
- What do we want our detector to do?

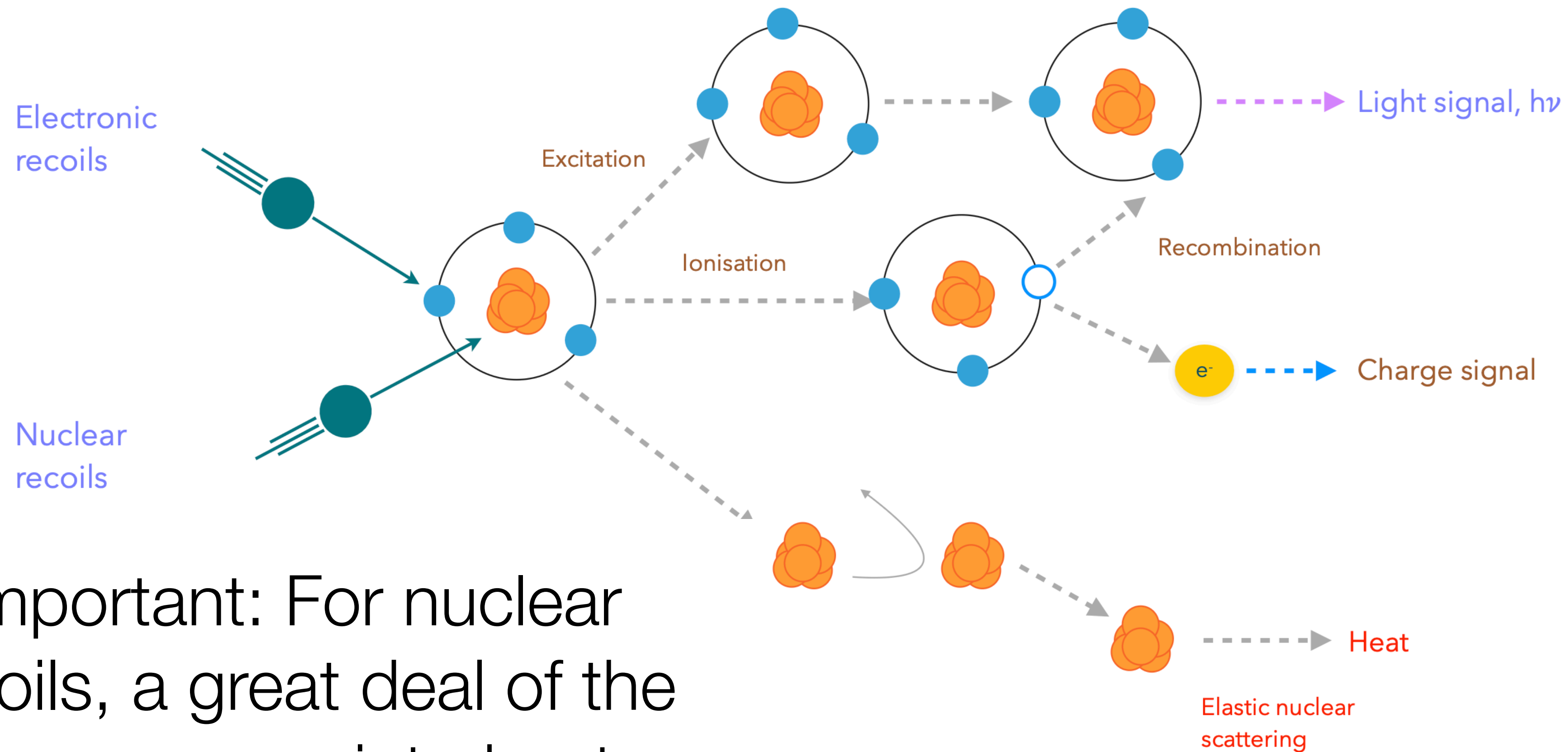

Important: For nuclear recoils, a great deal of the energy goes into heat

# Detectors

- All noble element detectors are going to collect light
  - Whether they all need to is something we'll come back to later
- The way that they collect it, and the way that they do background discrimination is going to vary
  - That could be pulse shape discrimination
  - Could be charge vs light
  - Could be something entirely different



# Types of Detectors

- We'll talk about three basic types of detectors — single phase, dual phase, and a special one at the end

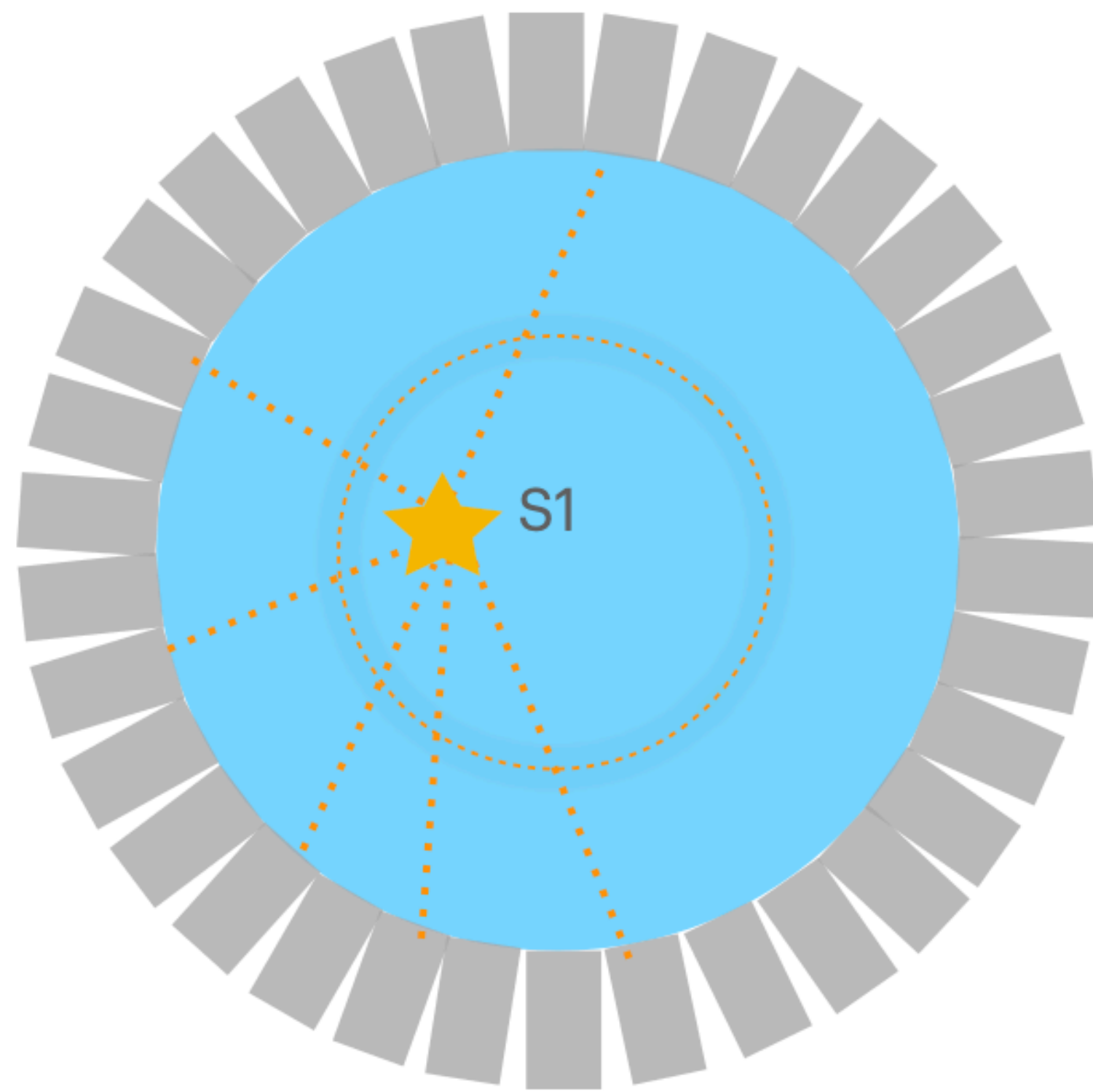

Single phase

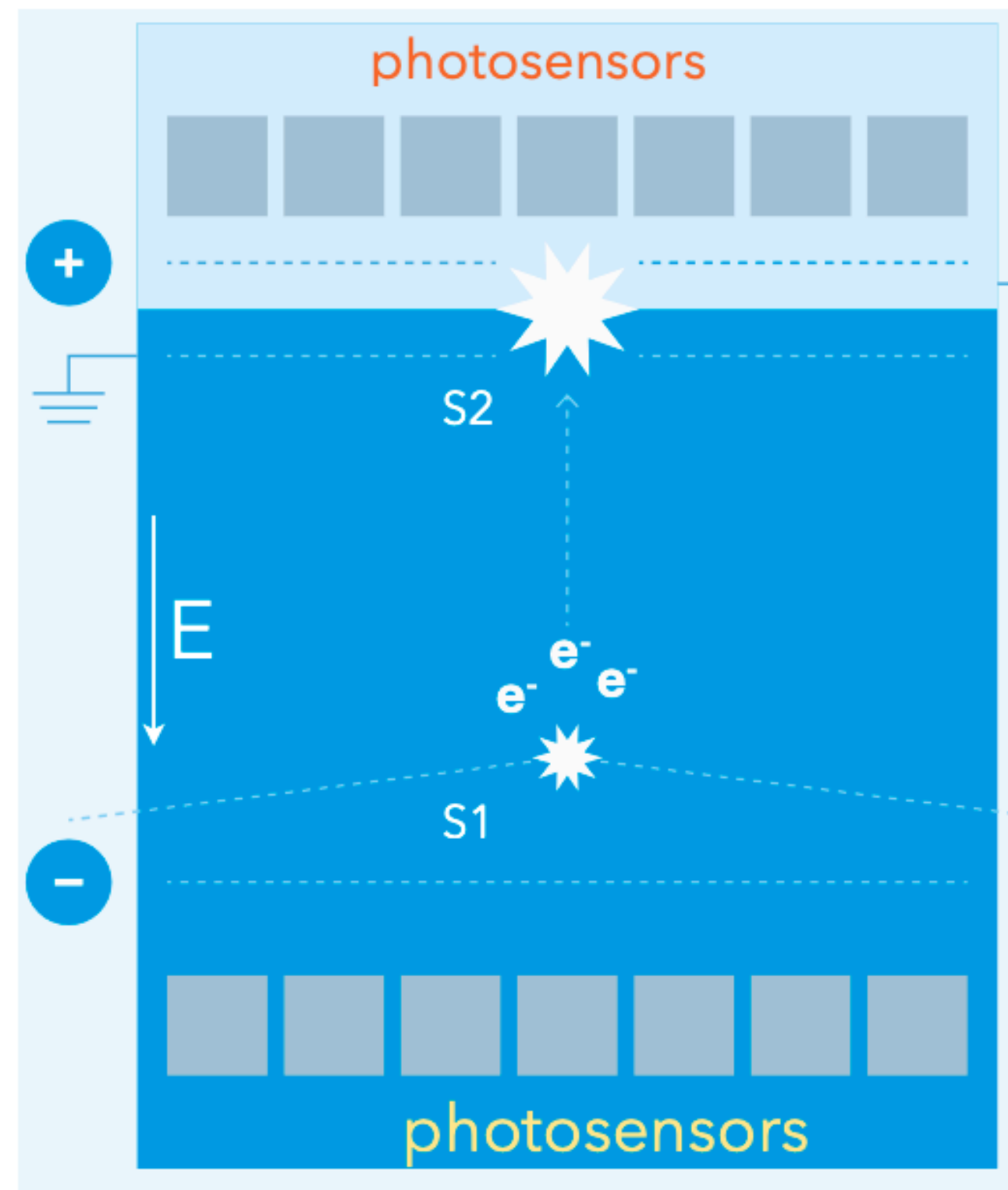

Dual phase

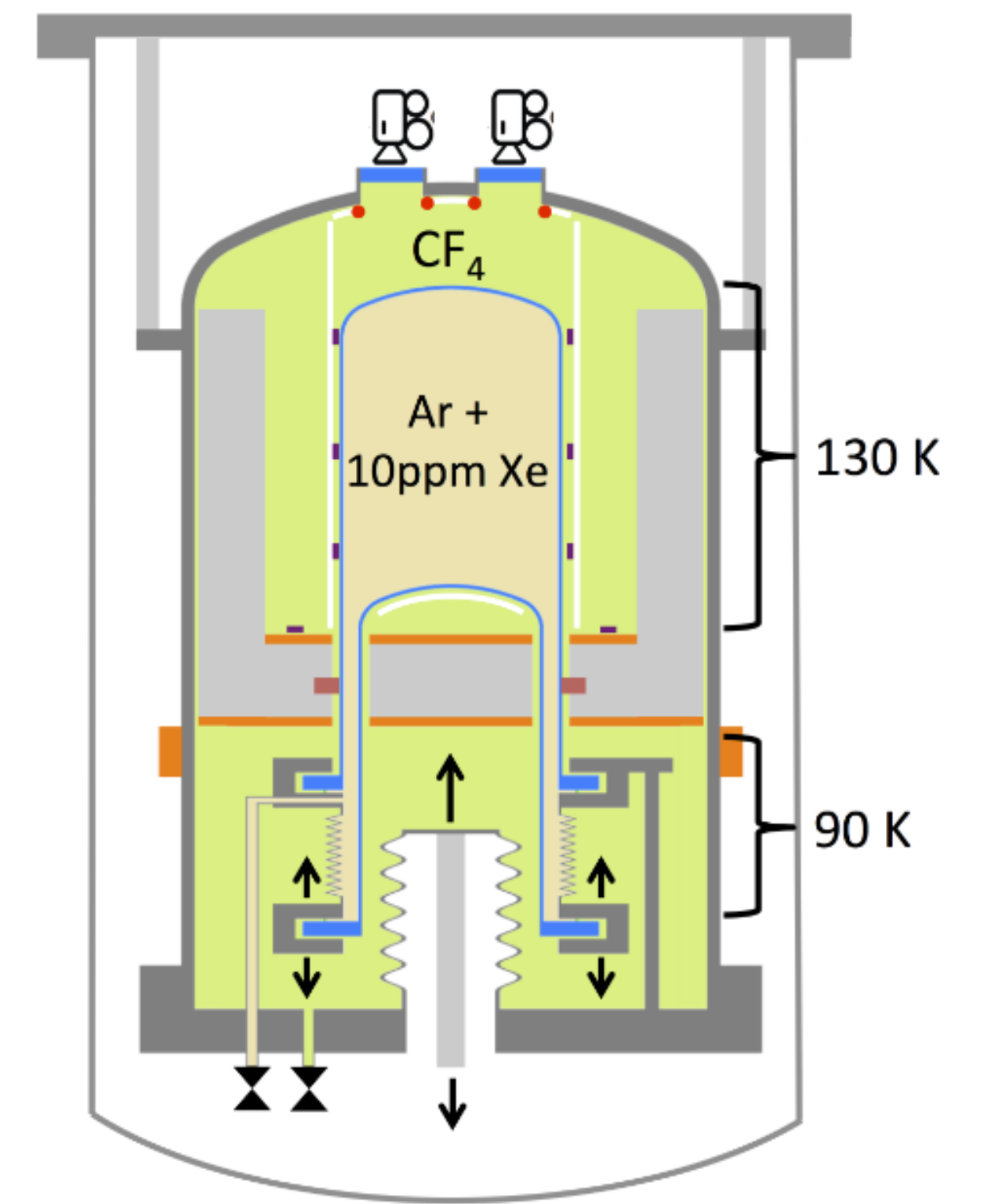

Bubble chamber

# Detectors - Challenges

- All of these will at least have portions of them that need to be kept at liquid noble temperatures
- All will collect light using technologies to change photons to usable signals
- All will need to be built from low-background materials compatible with the target medium
- All will need to be shielded from external backgrounds
- Some may need purification



# Detectors - Single Phase

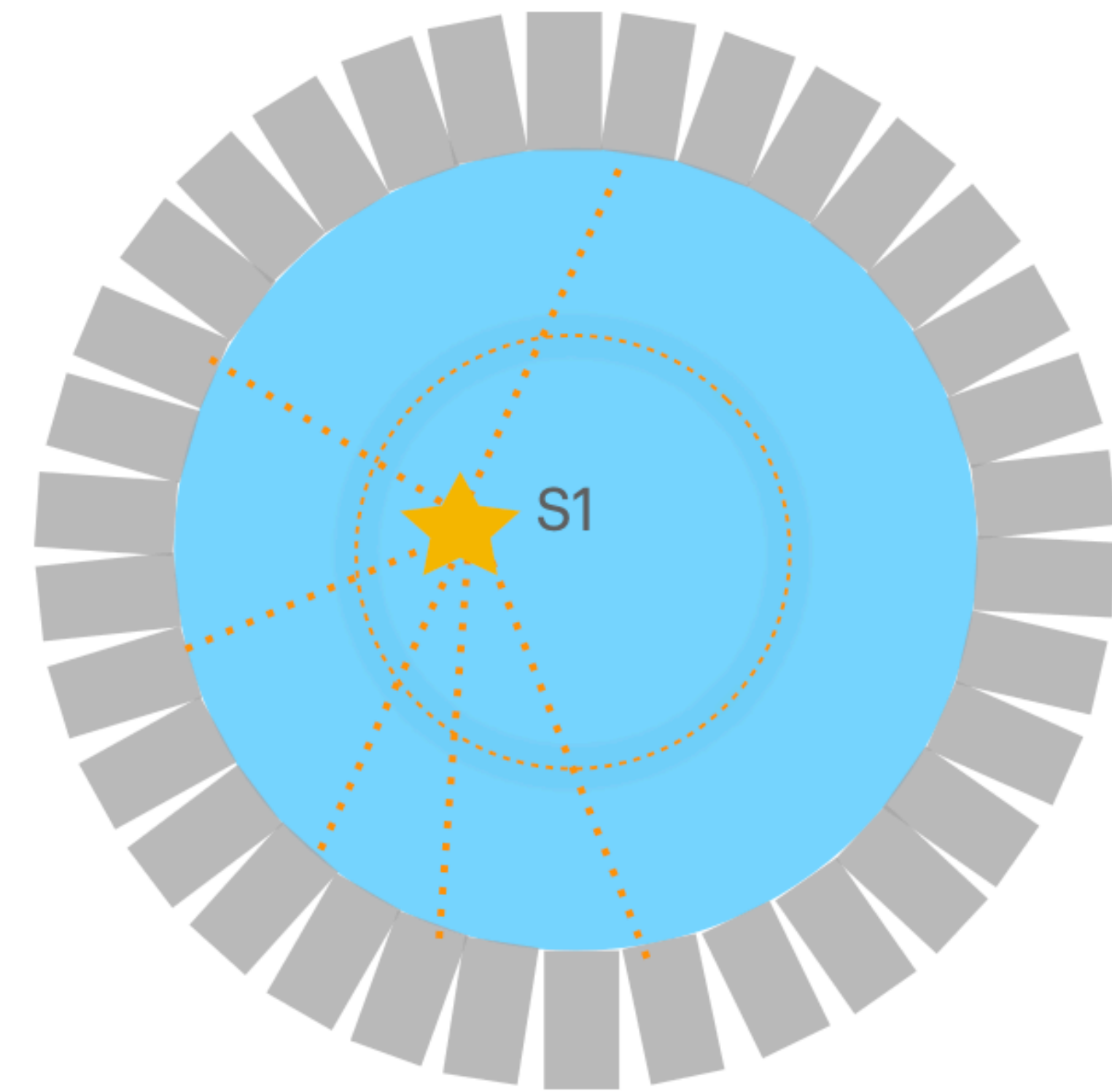

- Advantages:
  - High light yield (great coverage)
  - Simple geometry easy to simulate
  - Large homogeneous target material
- Challenges
  - No particle discrimination in LXe
  - Position resolution typically not great (few cm)
  - Low energy thresholds not really possible

# Detectors - Single Phase

- Example - the DEAP detector
- 3600kg of liquid argon (1000kg fiducial)
- Sphere with inner radius of 8cm made from 5cm thick acrylic
- Surrounded by 255 8" PMTs offset by standoffs
- Inner surface of the acrylic vessel is coated in TPB in order to make the detector work

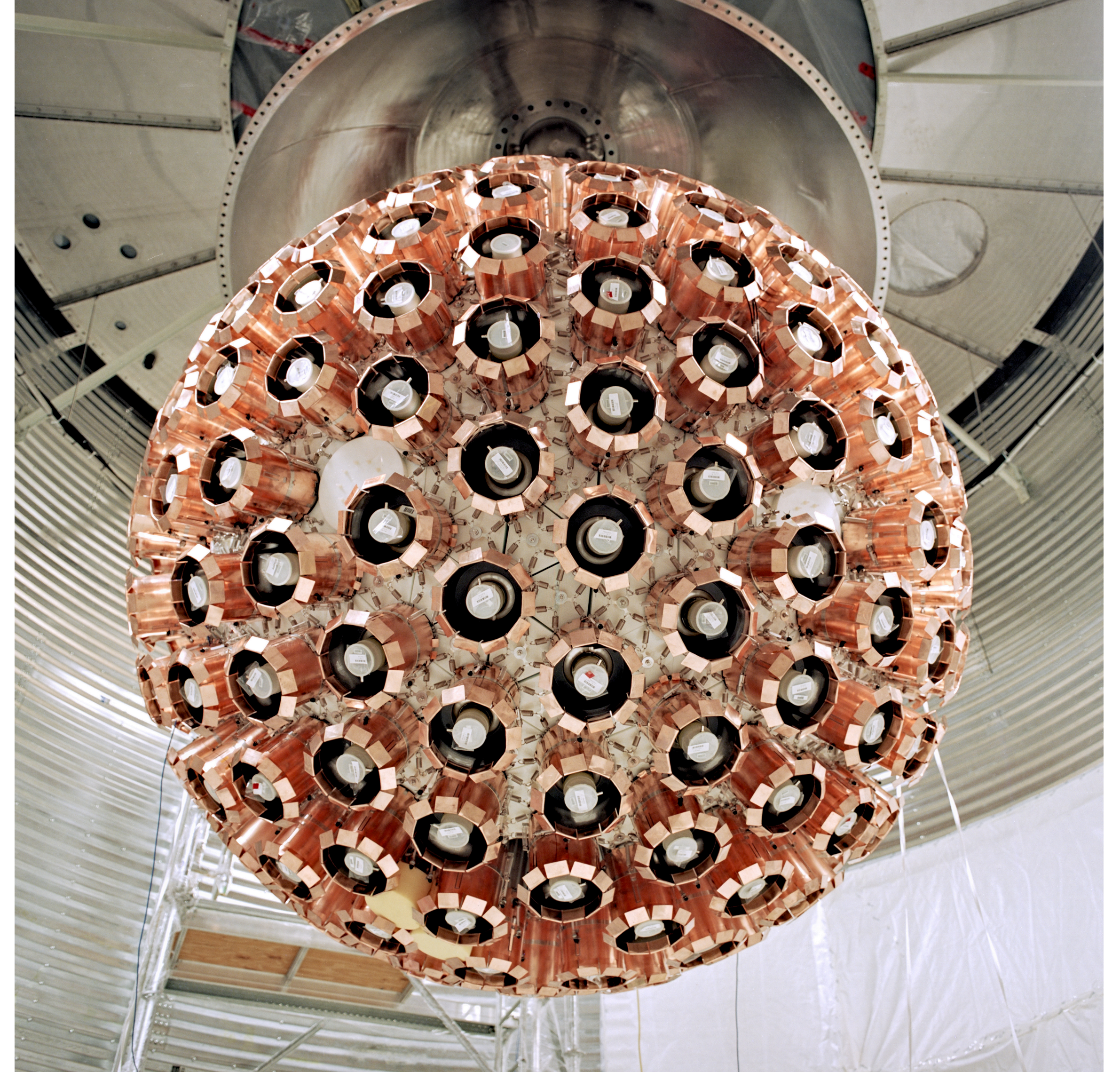

# Detectors - Single Phase

- Example - the DEAP detector
- 3600kg of liquid argon (1000kg fiducial)
- Sphere with inner radius of 8cm made from 5cm thick acrylic
- Surrounded by 255 8" PMTs offset by standoffs
- Inner surface of the acrylic vessel is coated in TPB in order to make the detector work

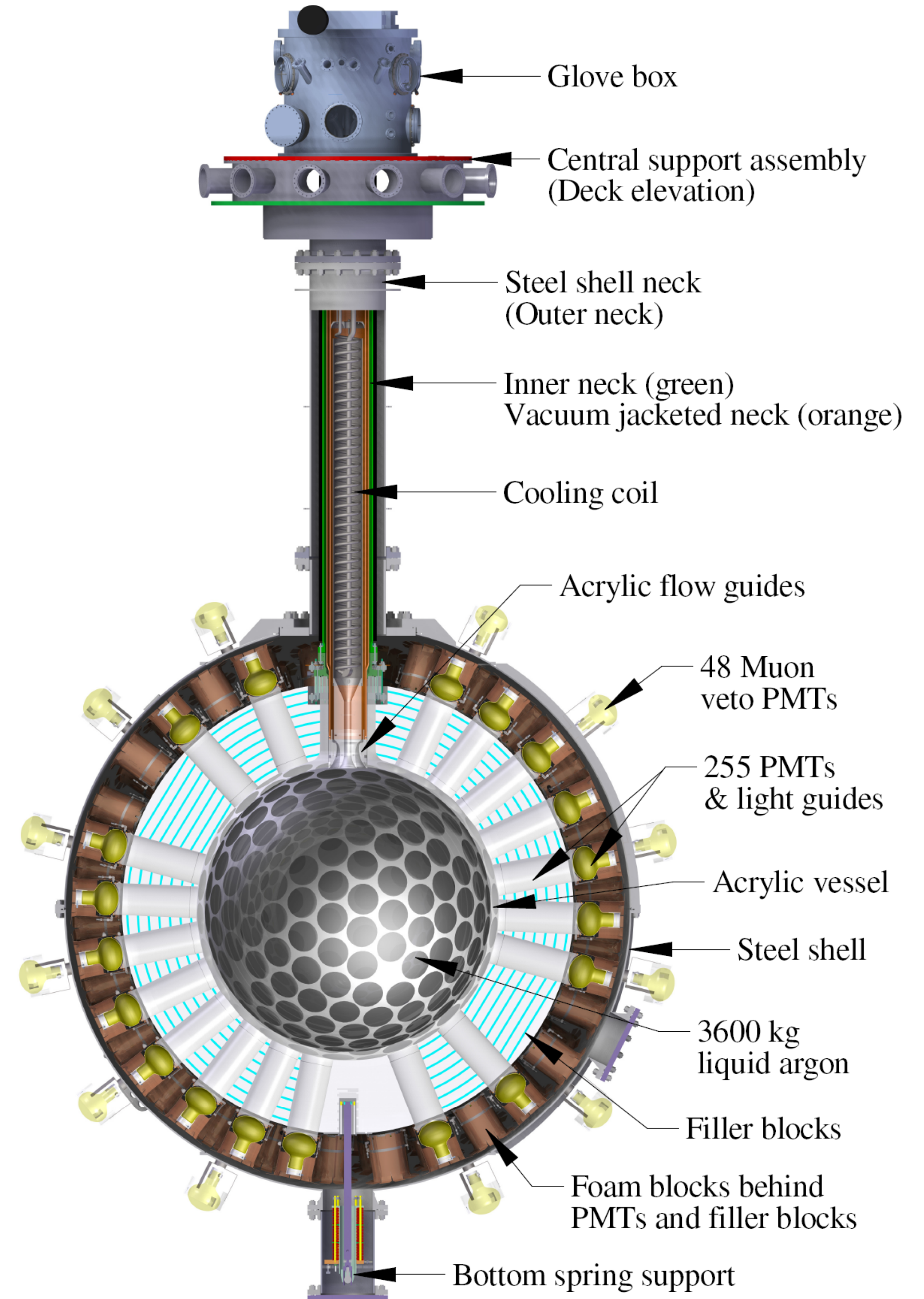

SOLID EDGE ACADEMIC COPY

# DEAP Discrimination

- As we said earlier, the proportions of the two excited states are different for our two signals
- This leads to different probabilities as shown in the plot here
- So let's walk through how the discrimination with backgrounds is actually done

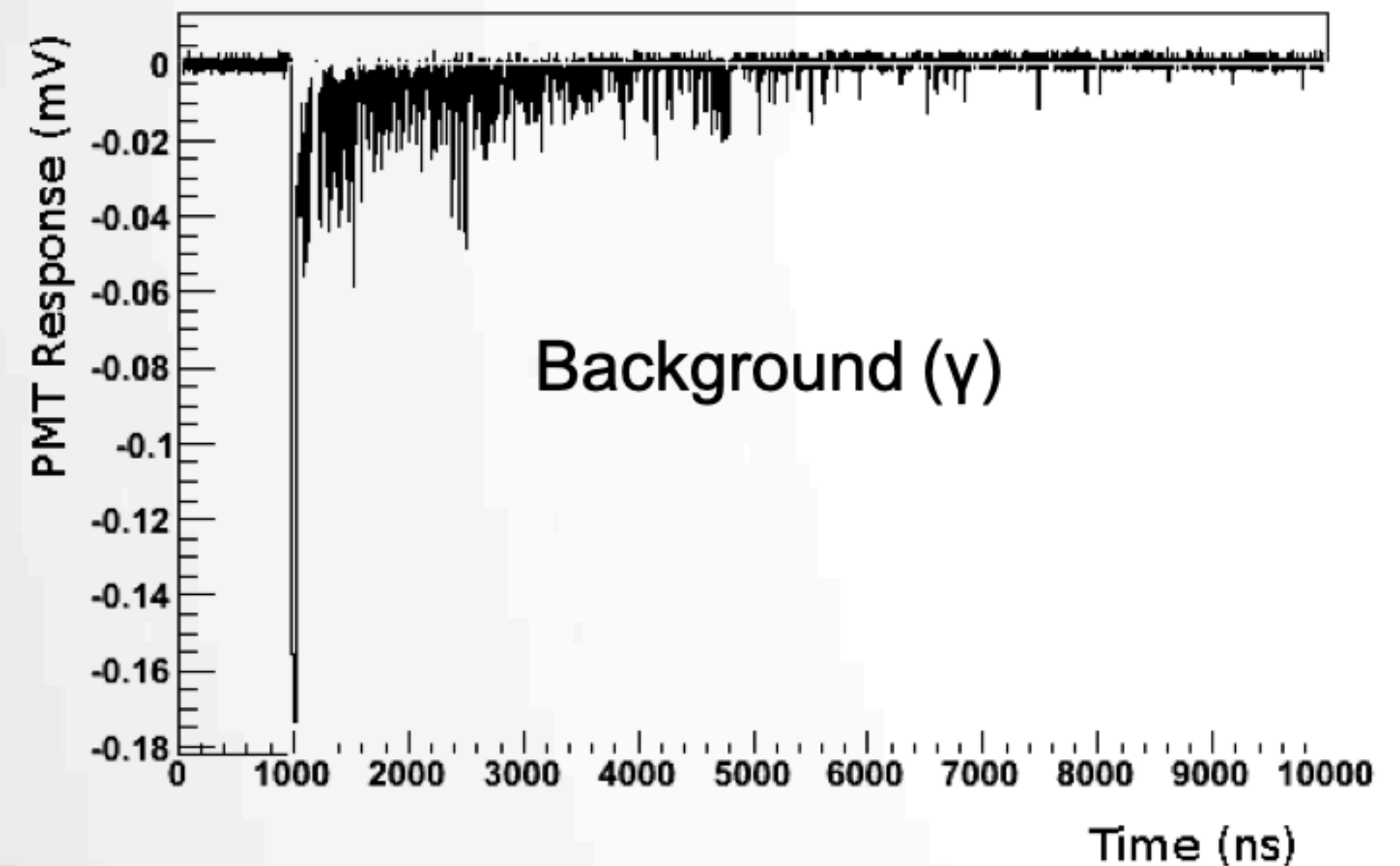
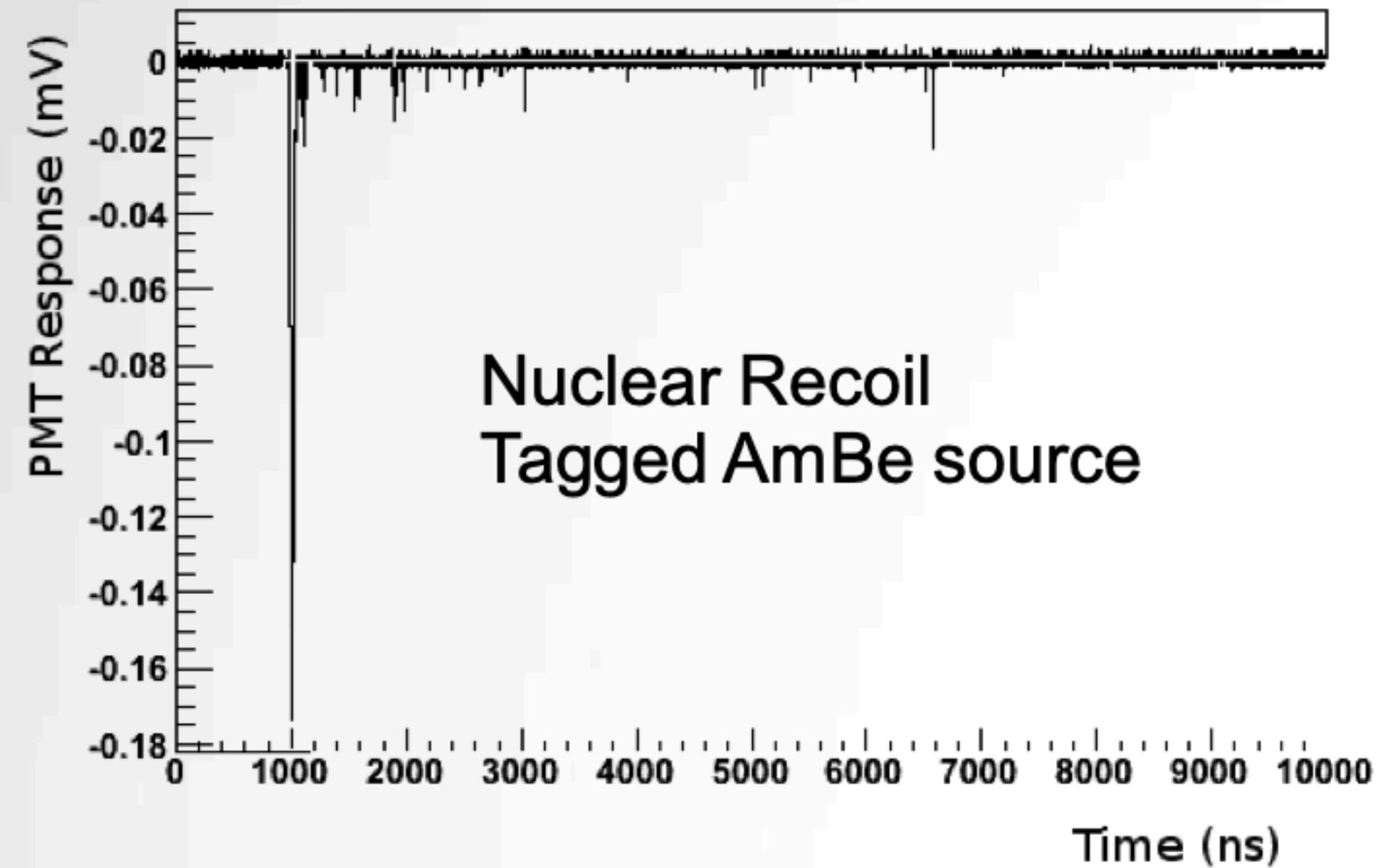

# DEAP Discrimination

- Start with a plot like this
- Shows the time of the photon arrival for two different interactions
- Here the nuclear recoil is created by a neutron source (AmBe) with a tag so that it is definitely a neutron
- The background is of gamma events
- Note the difference in the time of arrival even though the peak value is roughly the same

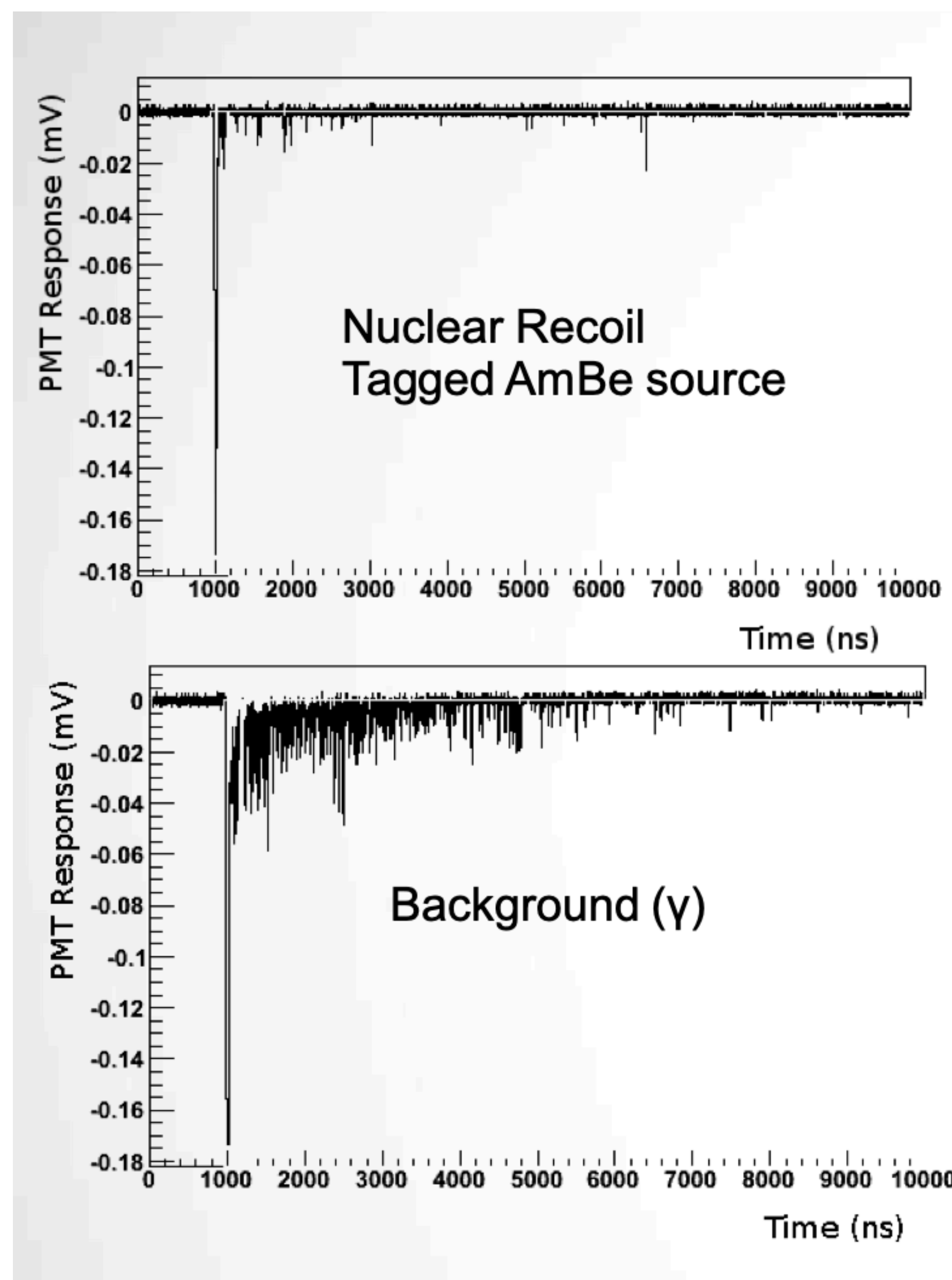

# DEAP Discrimination

- Define two regions
- The prompt light response (in red) and the later light response (in orange)
- Calculate a value representing the fraction of light which is “prompt”

$$f_{prompt} = \frac{N_{prompt}}{N_{prompt} + N_{late}}$$

- Here  $N_{prompt}$  could be counted within any time, but is 60ns

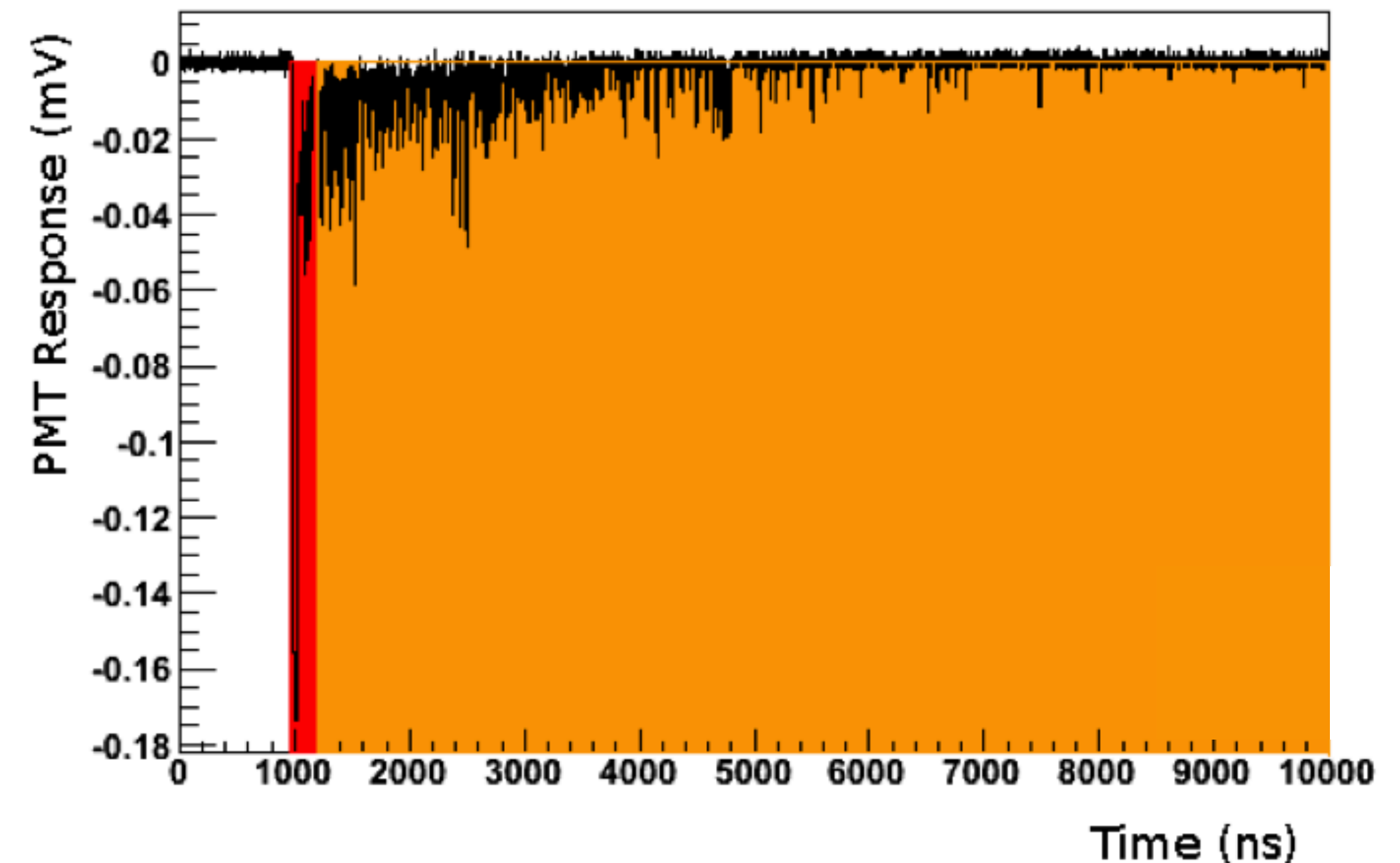
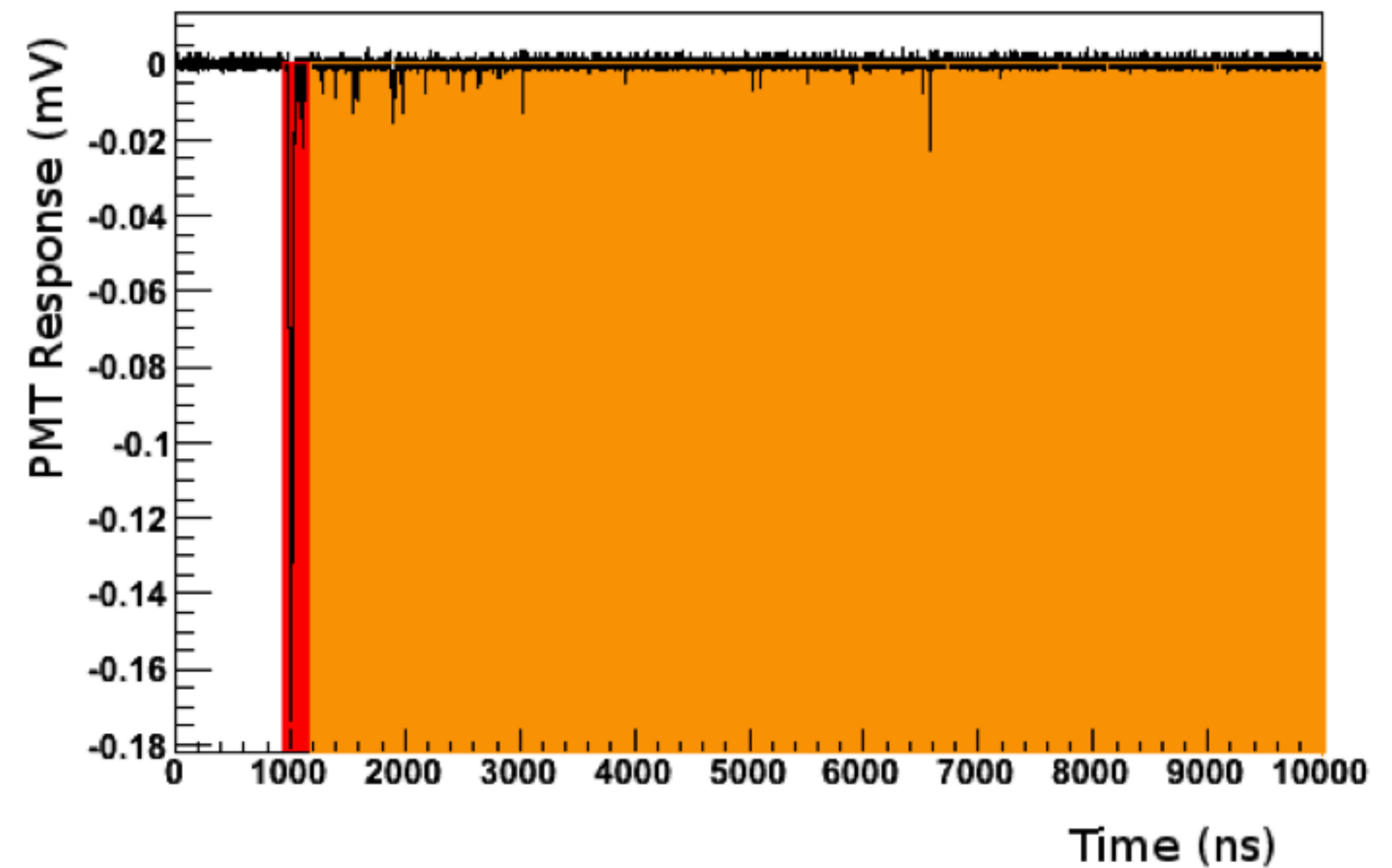

# DEAP Discrimination

- The ratio just described ( $f_{prompt}$ ) gives excellent separation between the nuclear recoils and electron recoils
- Shown in the plot here is a neutron source run

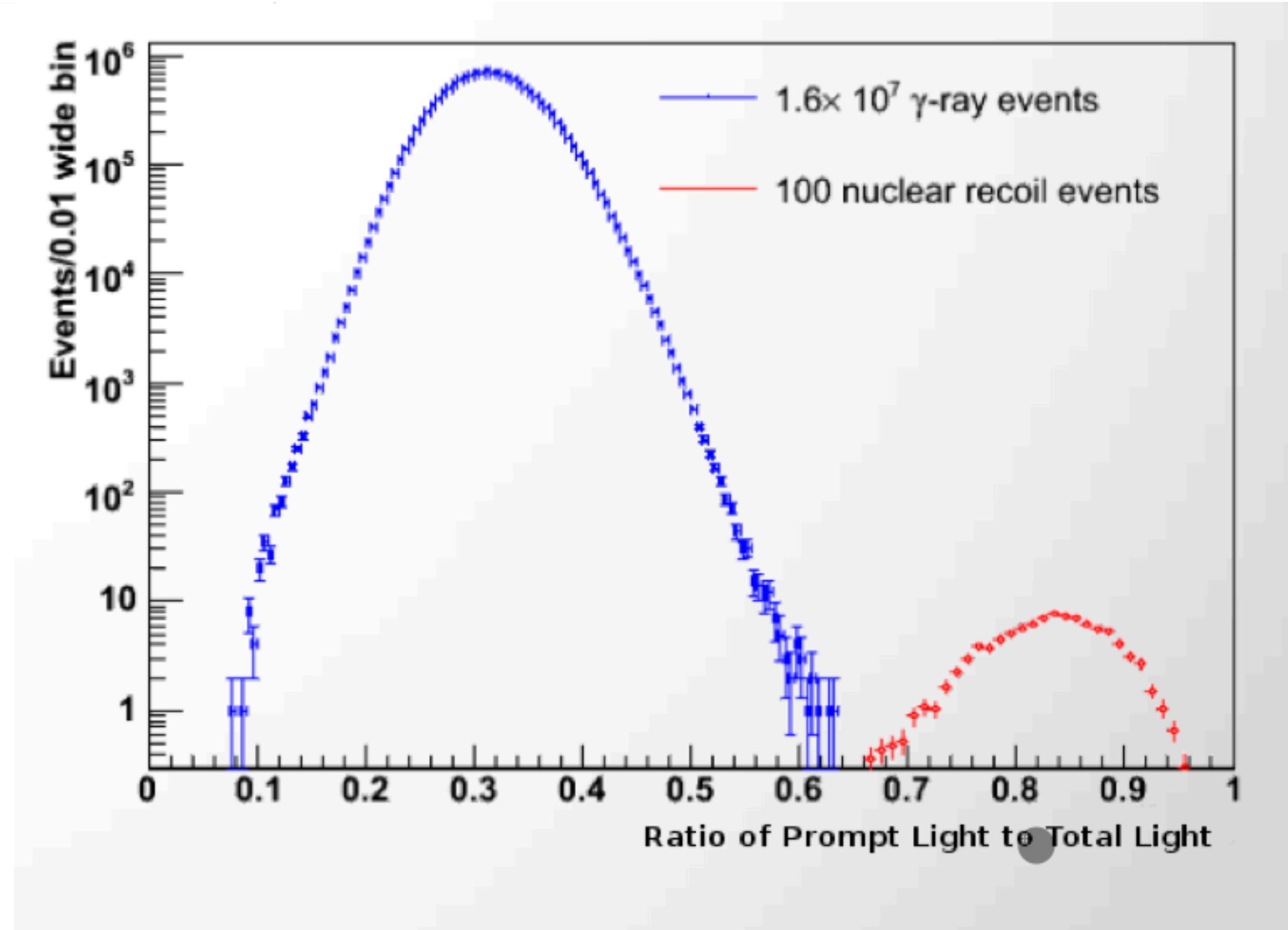

# DEAP Discrimination

- Plot  $f_{prompt}$  vs the total number of photoelectrons
- Then the two populations divide out nicely into electron recoils and nuclear recoils
- Define a region of interest well separated from the electron recoils that is “clean” and count how many you get
- This is compared to the predicted number

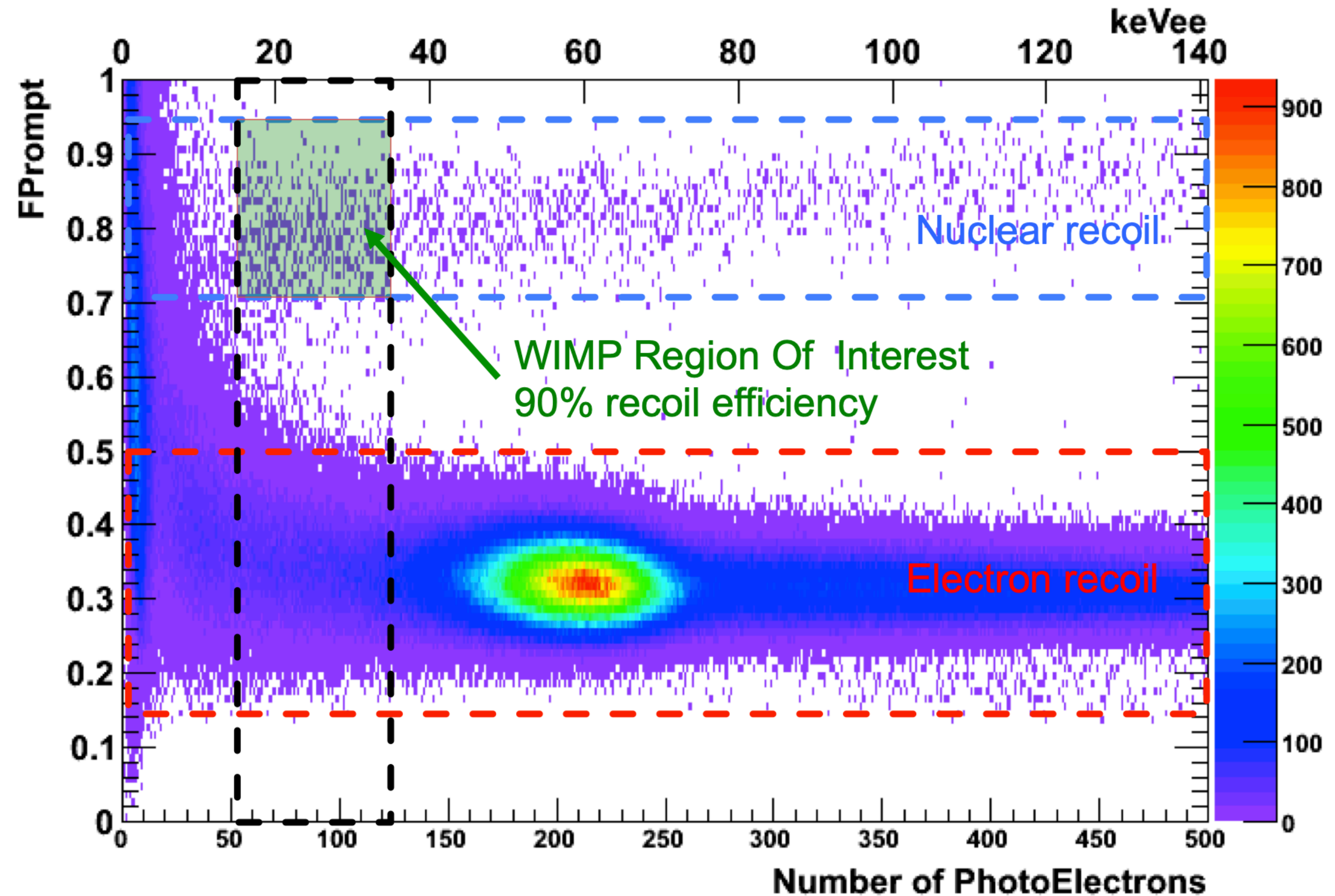

# Detectors - Two Phase

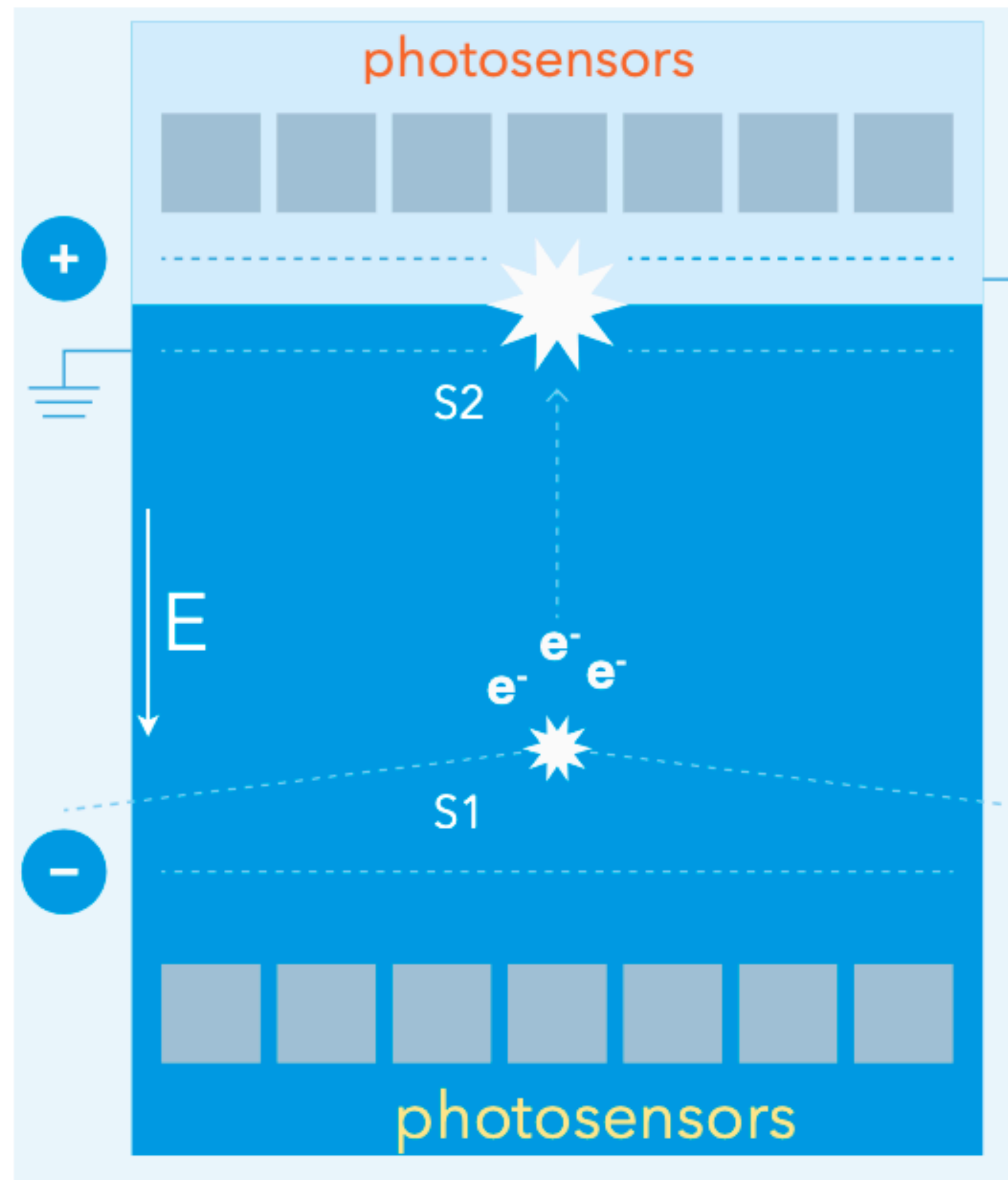

- Advantages
  - 3D position reconstruction
  - Excellent low-energy threshold
  - Good multiple scatter discrimination
- Challenges
  - Complex detector geometry
  - Need large electric fields
  - Also need precise liquid level control

# Detectors - Two Phase

- Two-phase detector operation is complicated
- Particle comes in and causes scintillation, giving the “S1” signal
- Ionized electrons are drifted up toward the liquid/gas interface
- These are extracted from the liquid and accelerated by another field, producing showers and electroluminescence, the “S2” signal

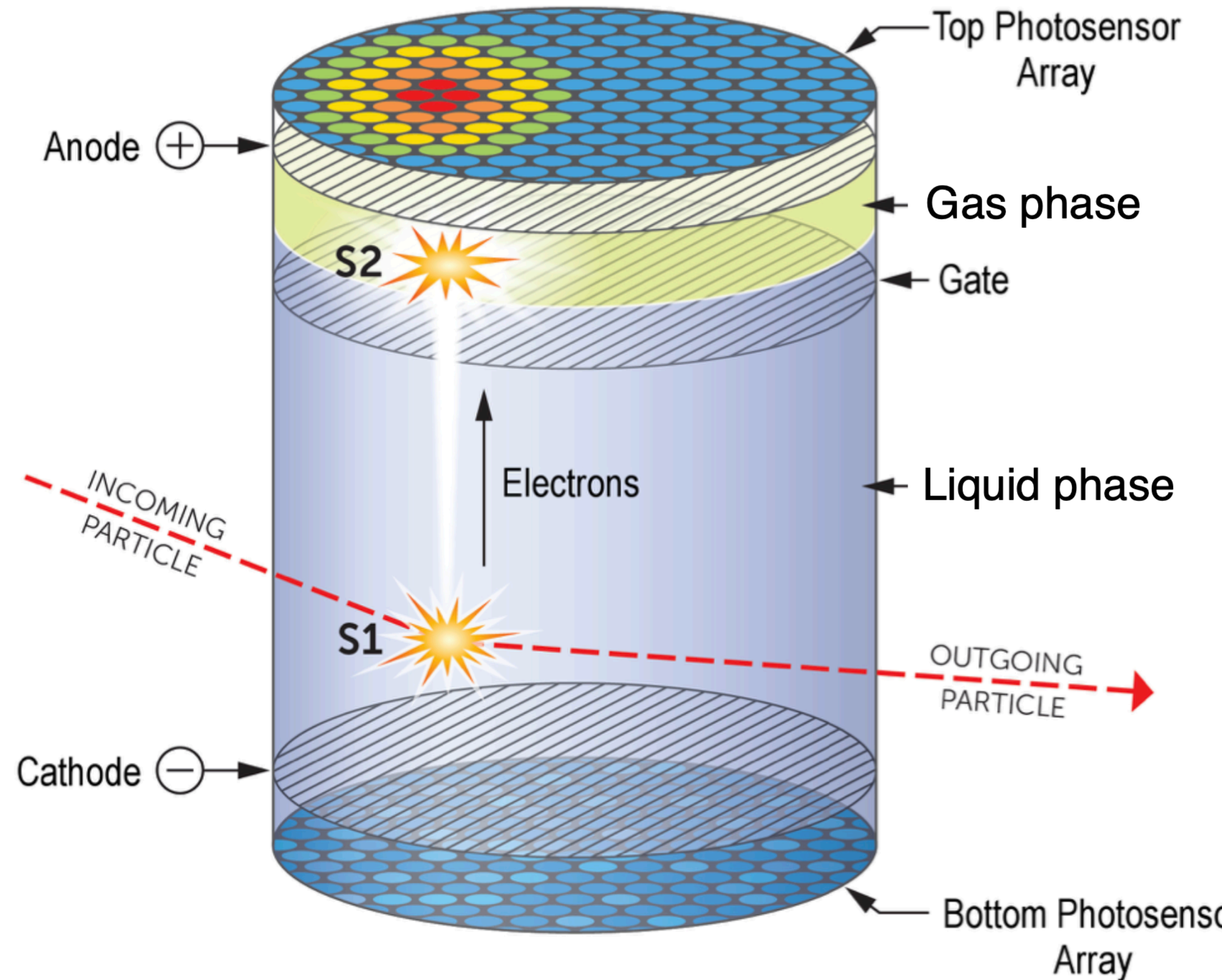

# The LZ Detector



- Example - The LZ detector
- 7000kg of liquid xenon, 5600kg fiducial
- Gas layer on top is 8mm thick
- Watched by 494 PMTs (241 looking up, 253 looking down)
  - These require roughly 20km of cabling...
- The outer detector is instrumented as a veto, as is the xenon outside the PTFE panels

# The LZ Detector

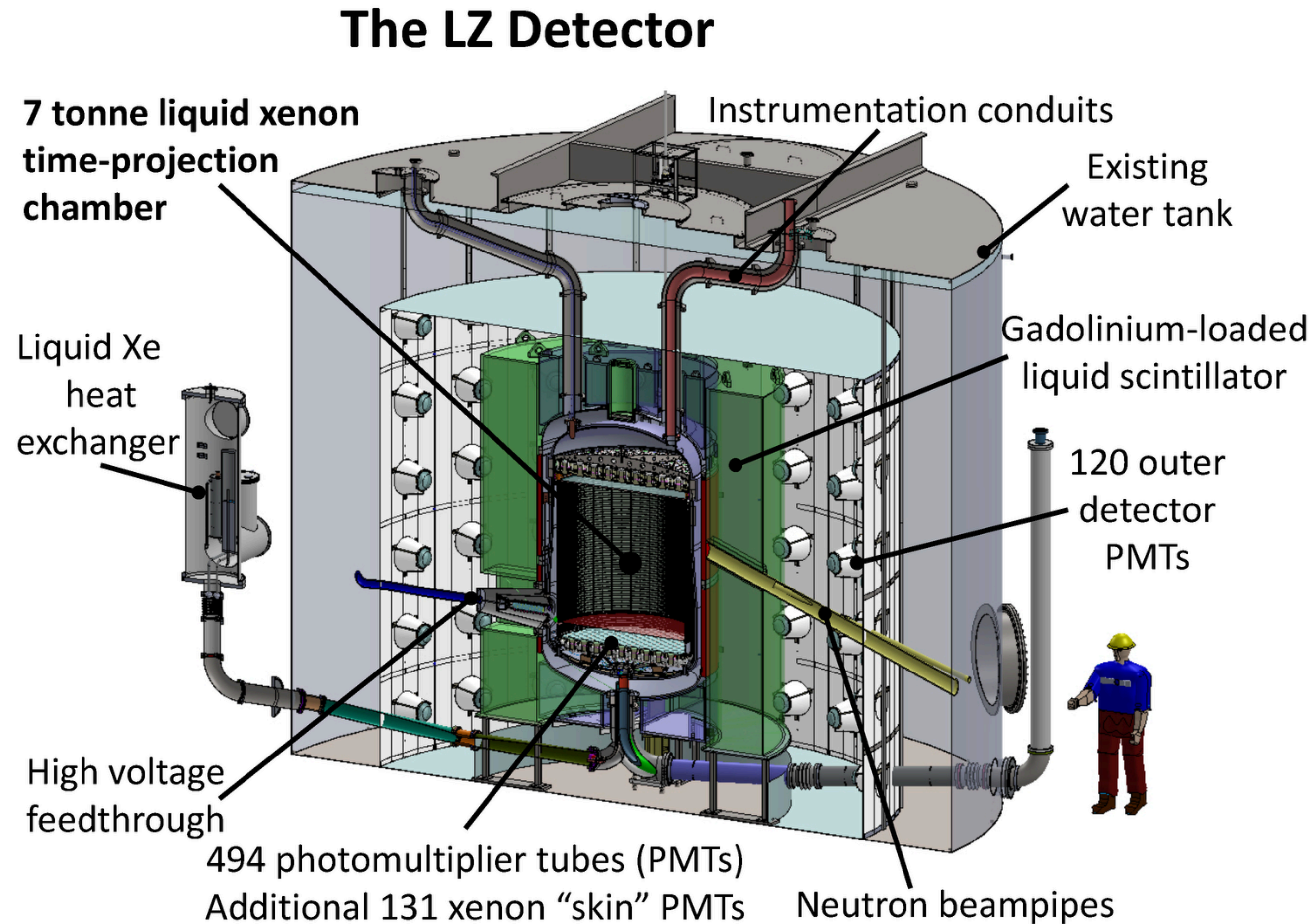

- Example - The LZ detector
- 7000kg of liquid xenon, 5600kg fiducial
- Gas layer on top is 8mm thick
- Watched by 494 PMTs (241 looking up, 253 looking down)
  - These require roughly 20km of cabling...
- The outer detector is instrumented as a veto, as is the xenon outside the PTFE panels

# Discrimination in LZ

- The signals coming from two-phase xenon detectors contain a lot of information
- The time between S1 and S2 gives the z-position of the event
- The S1/S2 ratio is important for discrimination — due to the proportion of scintillation vs ionization, gammas produce more electrons

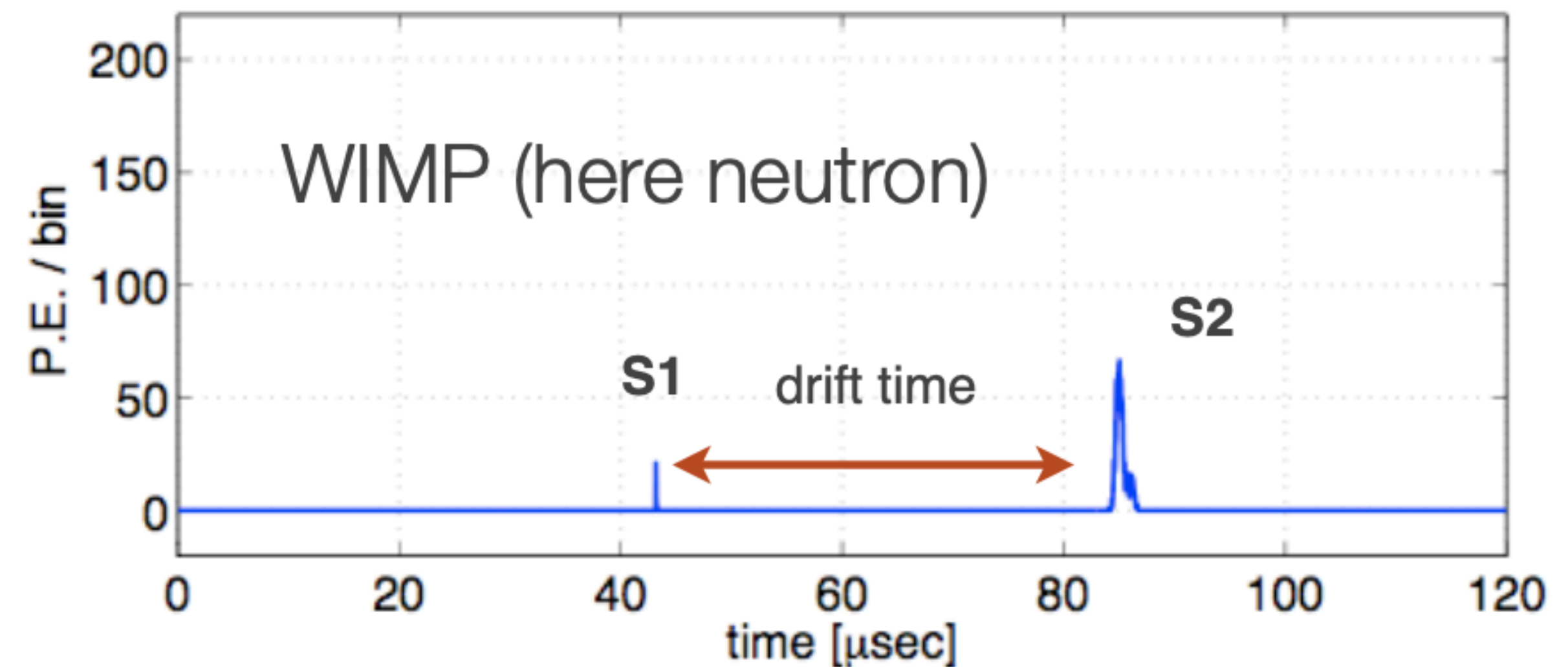
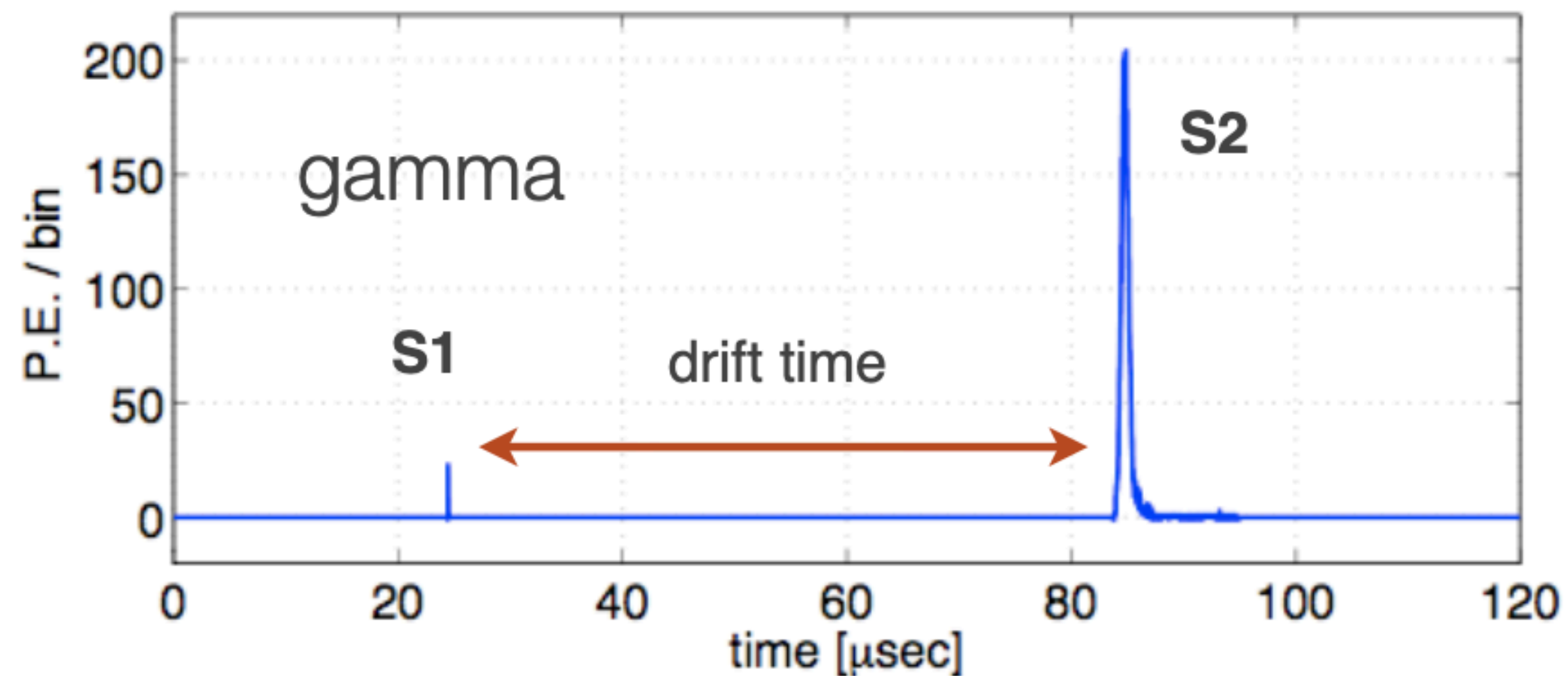

# Discrimination in LZ

- Here the number of photons for each of the S1 and S2 are plotted (log for S2)
- The different notation (S1c, S2c) represents a correction to the number of photons due to geometric effects
- The separation is shown in the lines, with the 10% and 90% quantiles shown

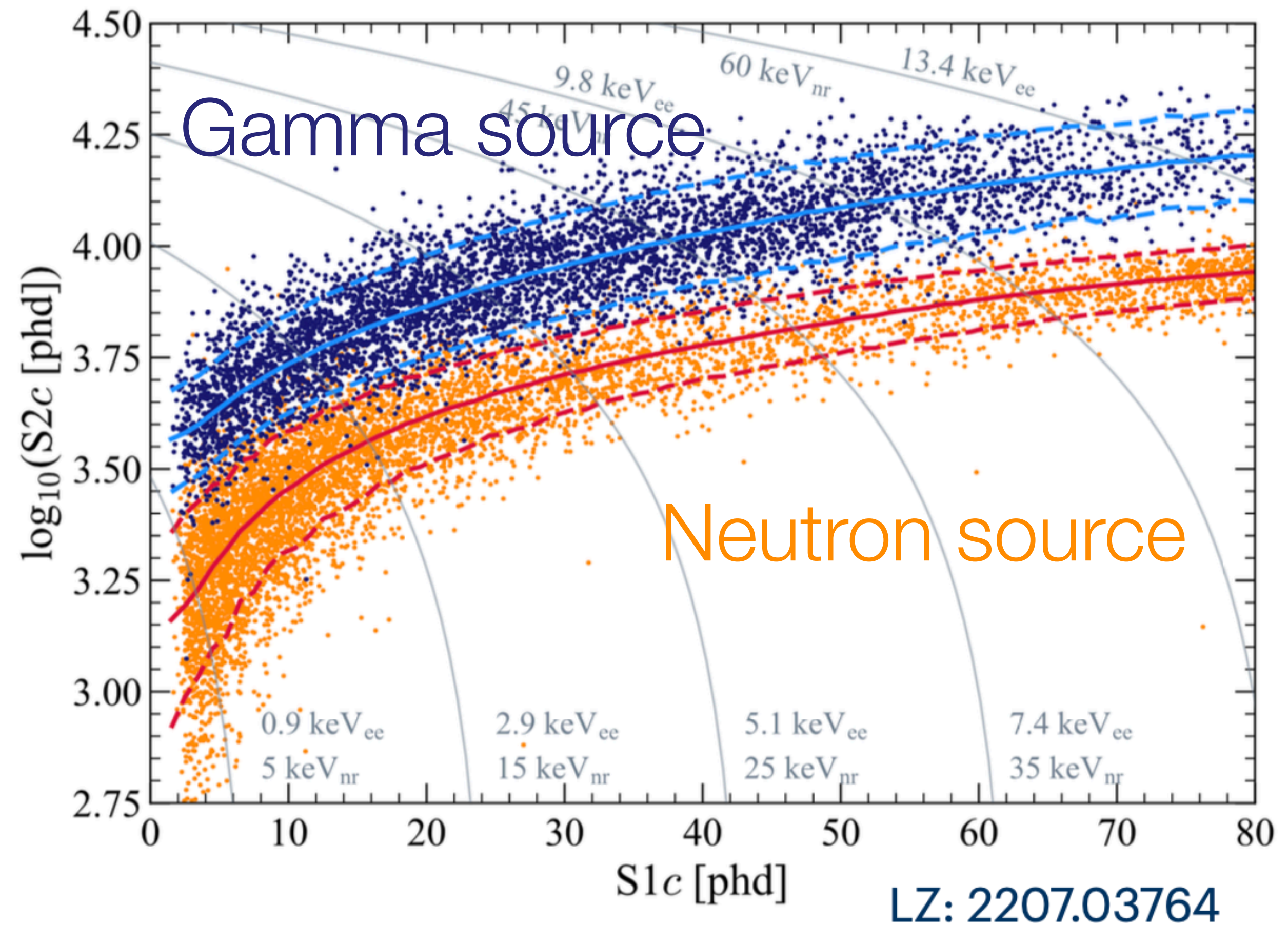

# Bubble Chambers

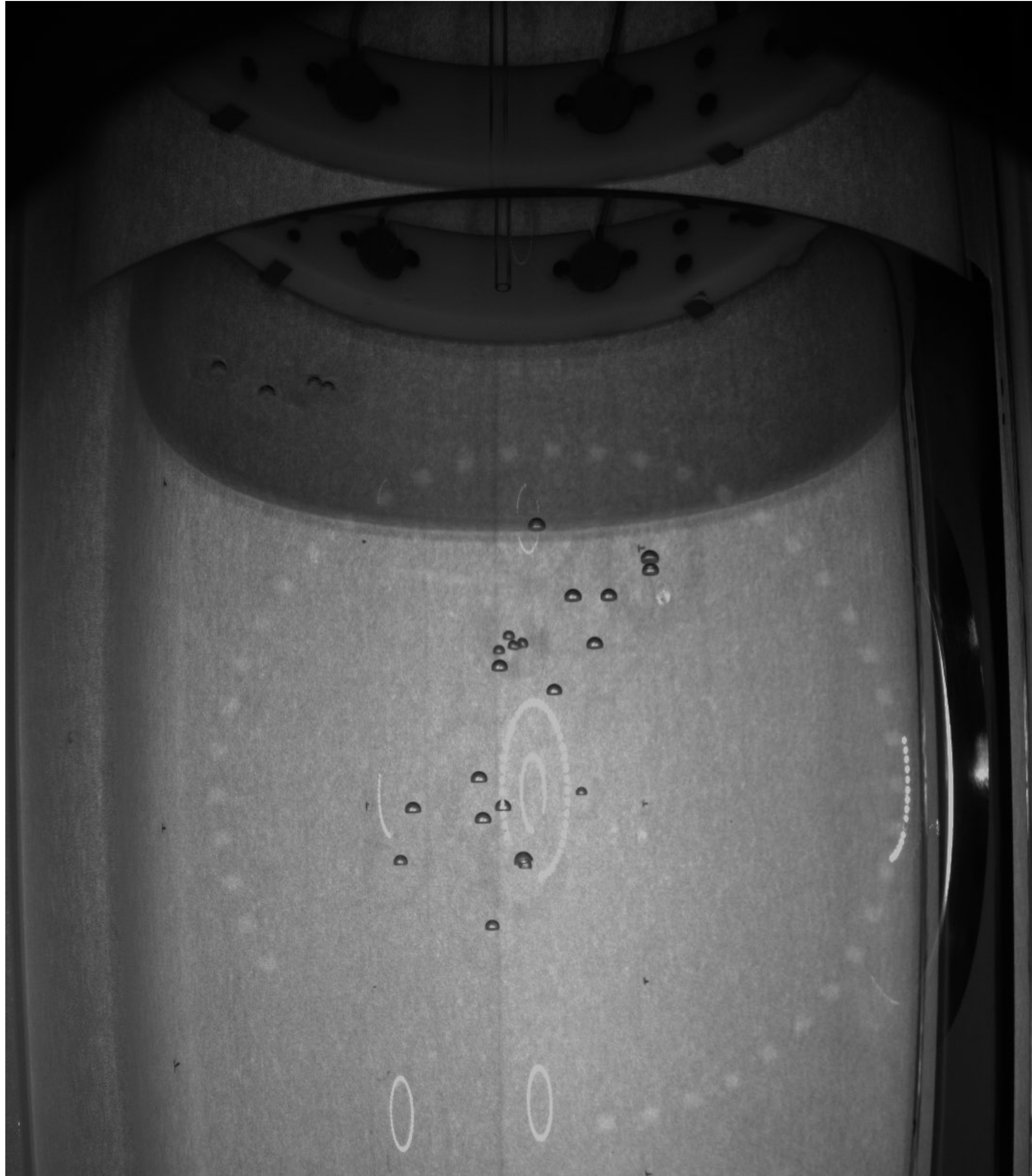

- Long history with particle physics, and even with dark matter
- Particle interaction causes nucleation in superheated fluid
- This grows into a visible (and detectable) bubble
- Chamber can then be recompressed and ready for the next event



# Theory, Graphically

- At high pressure the medium is stable in the liquid state

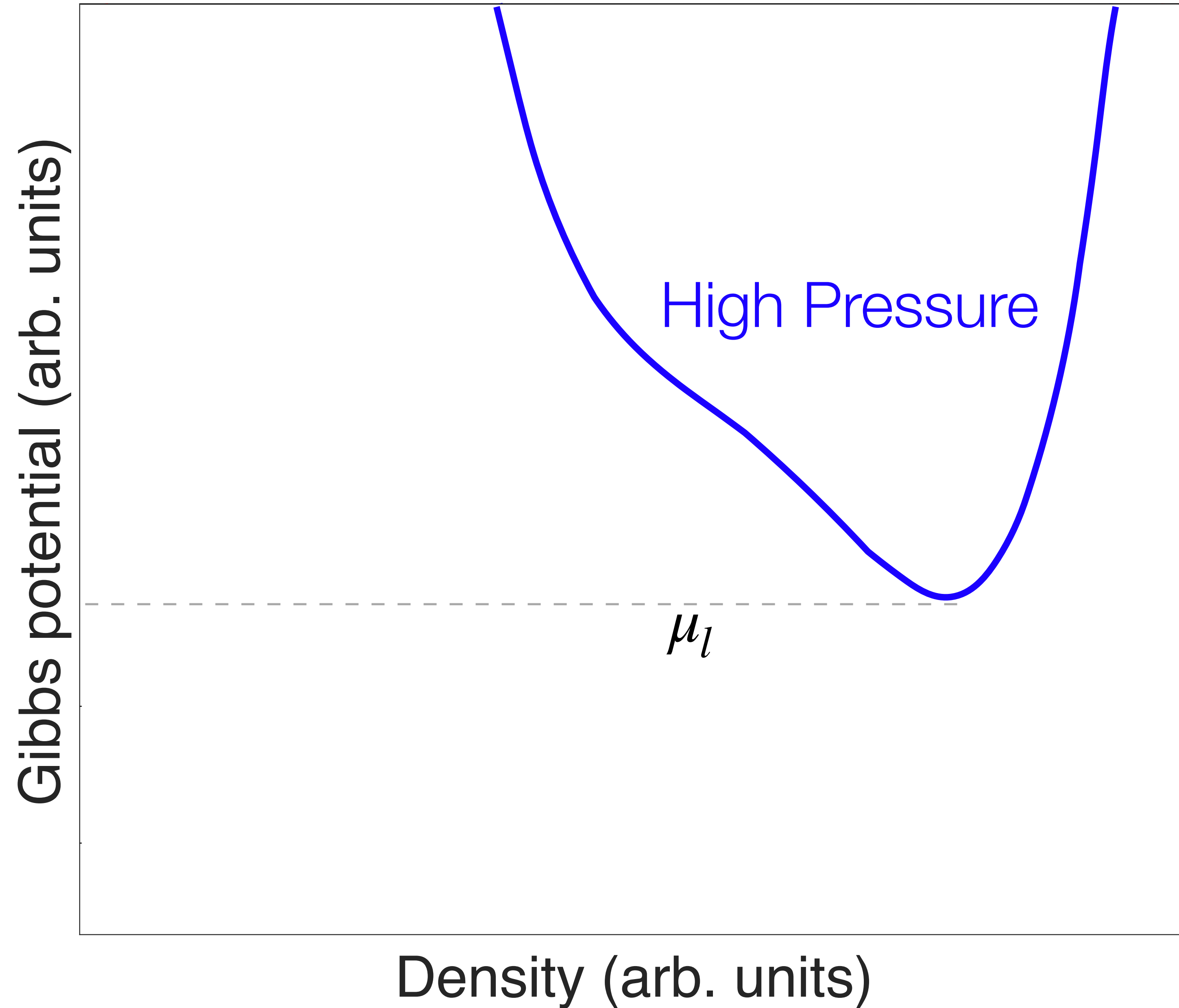

# Theory, Graphically

- As the pressure is lowered, this becomes metastable, with a potential threshold to overcome before changing state

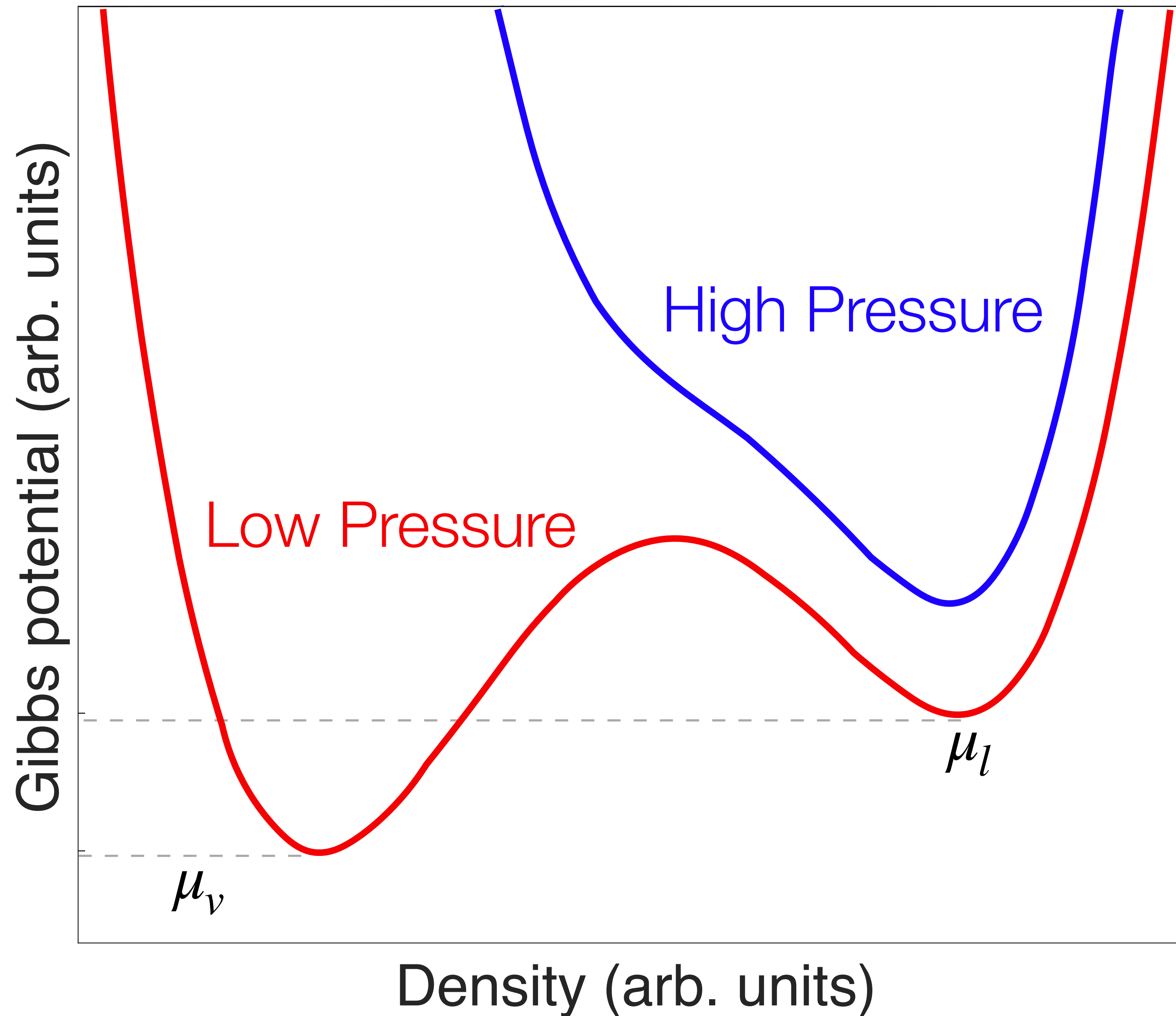

# Theory, Graphically

- The potential step is controllable with pressure (or temperature) providing a variable threshold

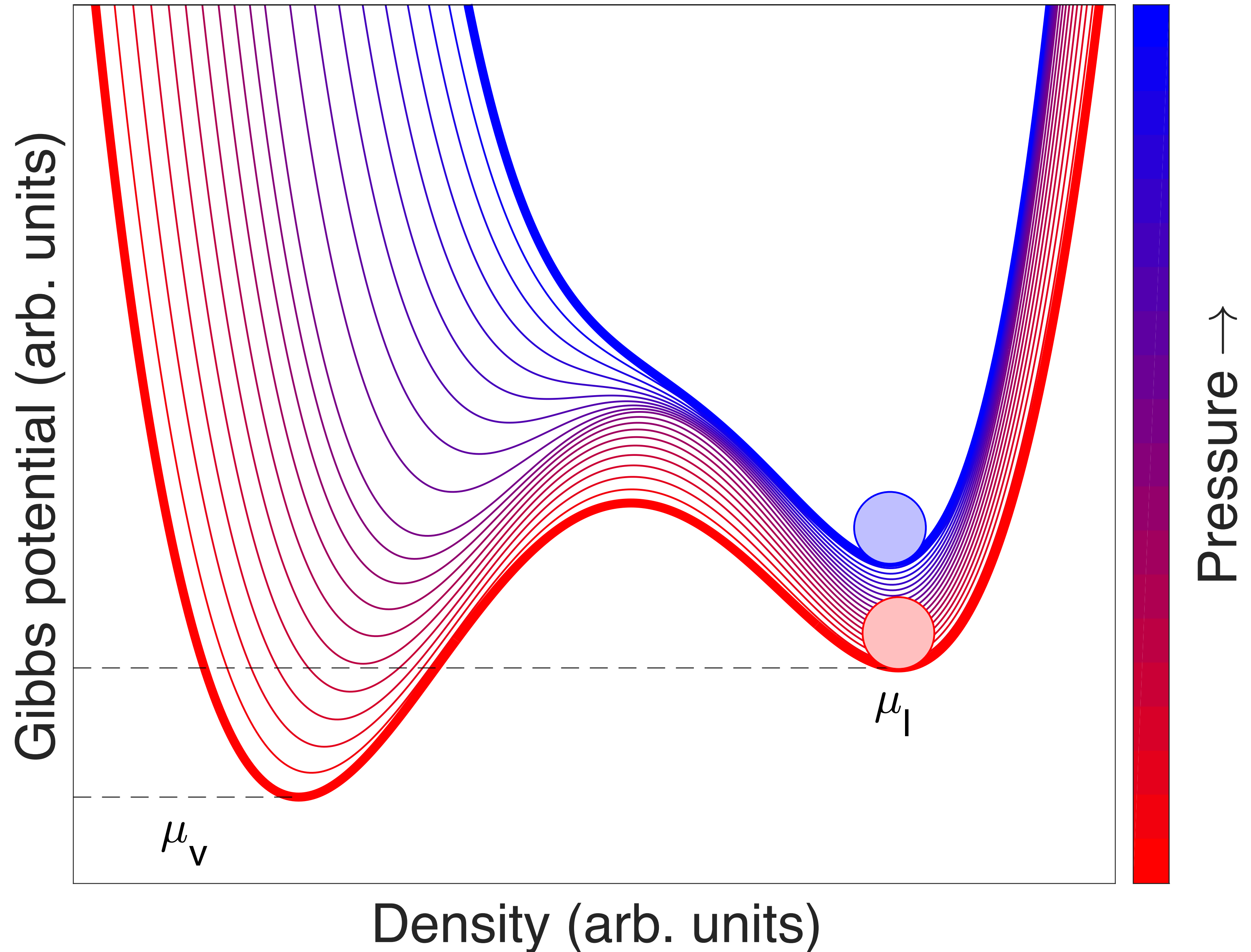

# Experiment Overview

- Bubble chambers have been used for dark matter searches with success (see: PICO)
- Low mass region remained out of reach due to increased electron recoils with a lowered threshold

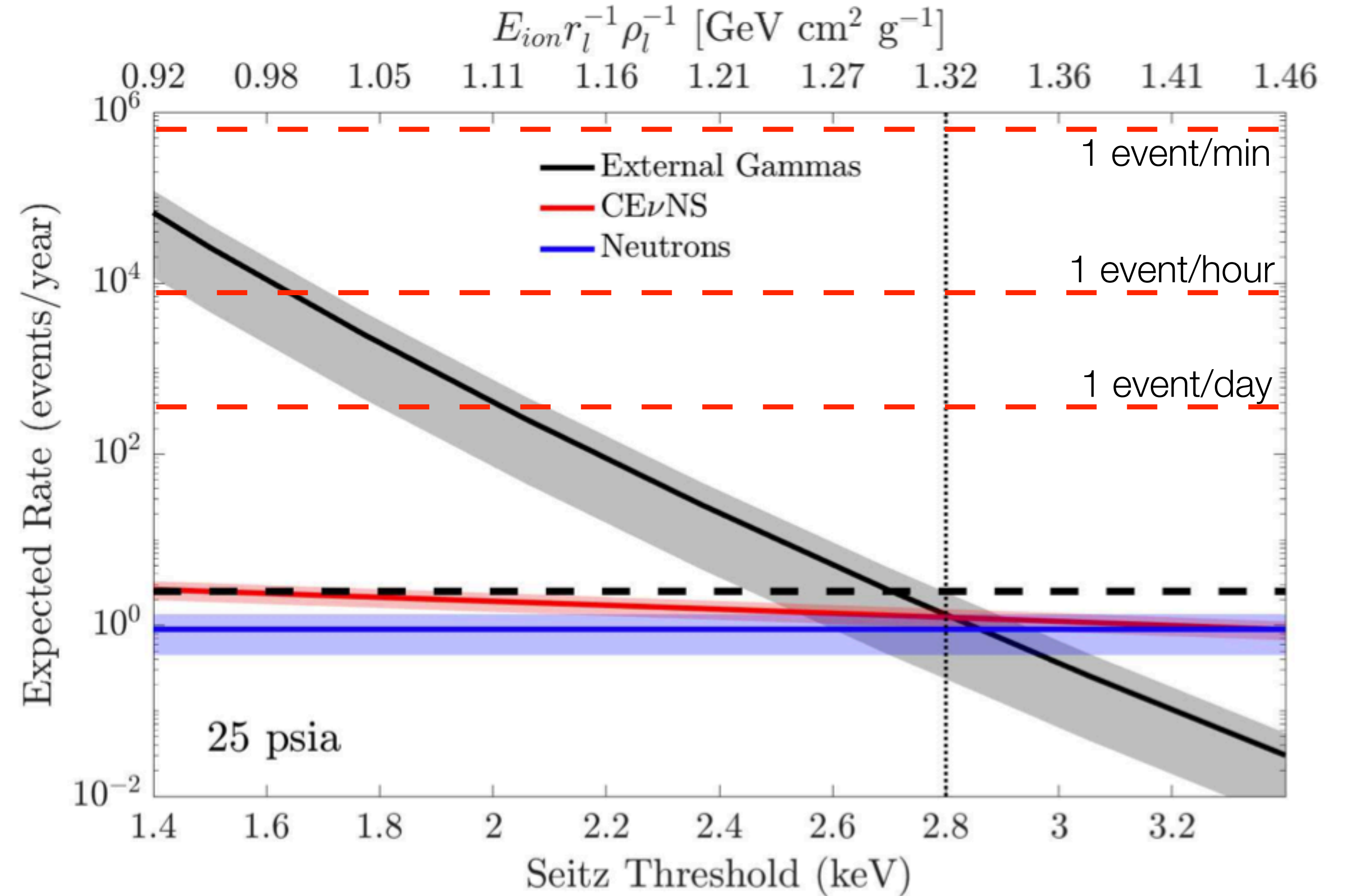

# Why do we think this will work?

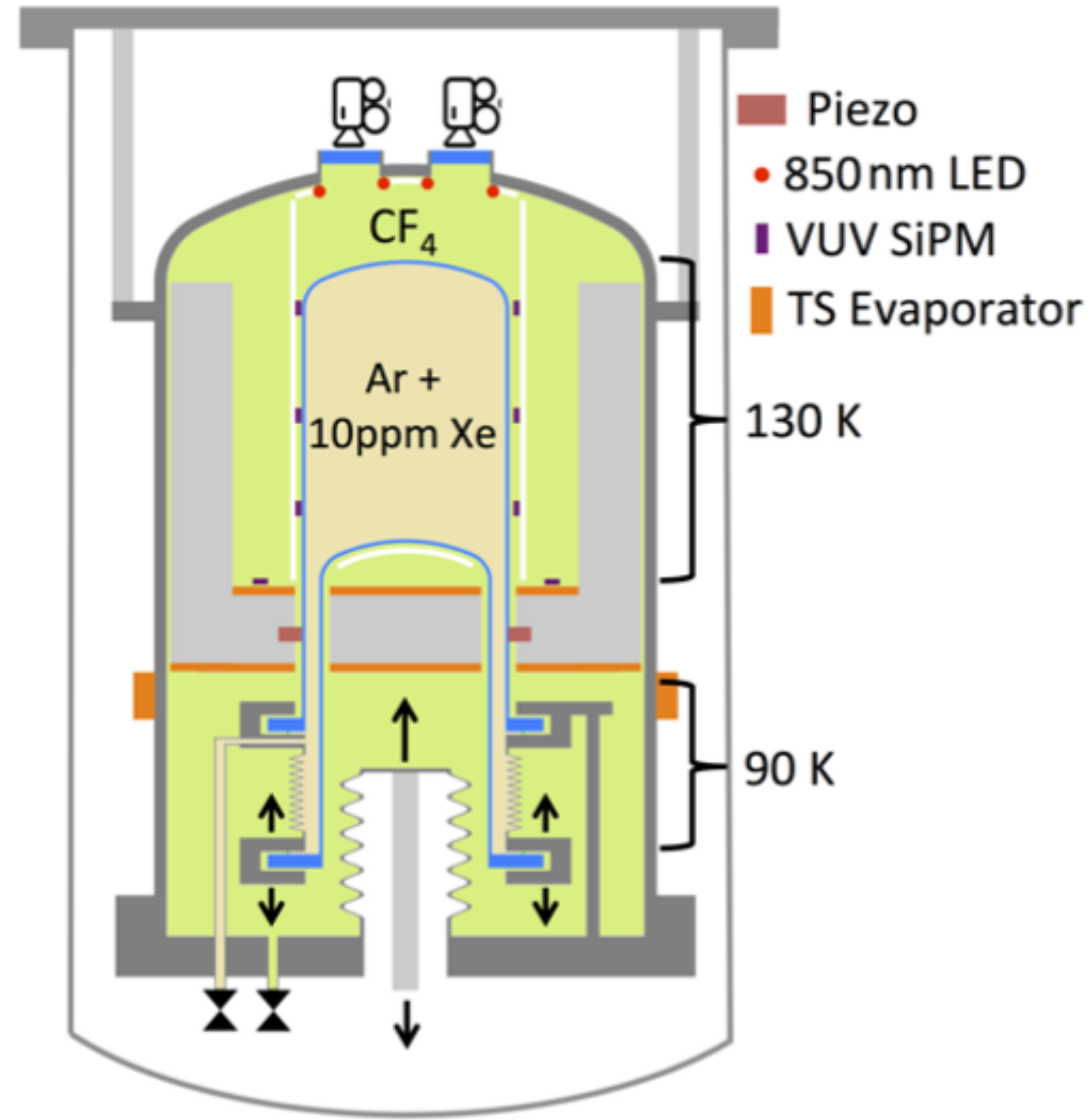
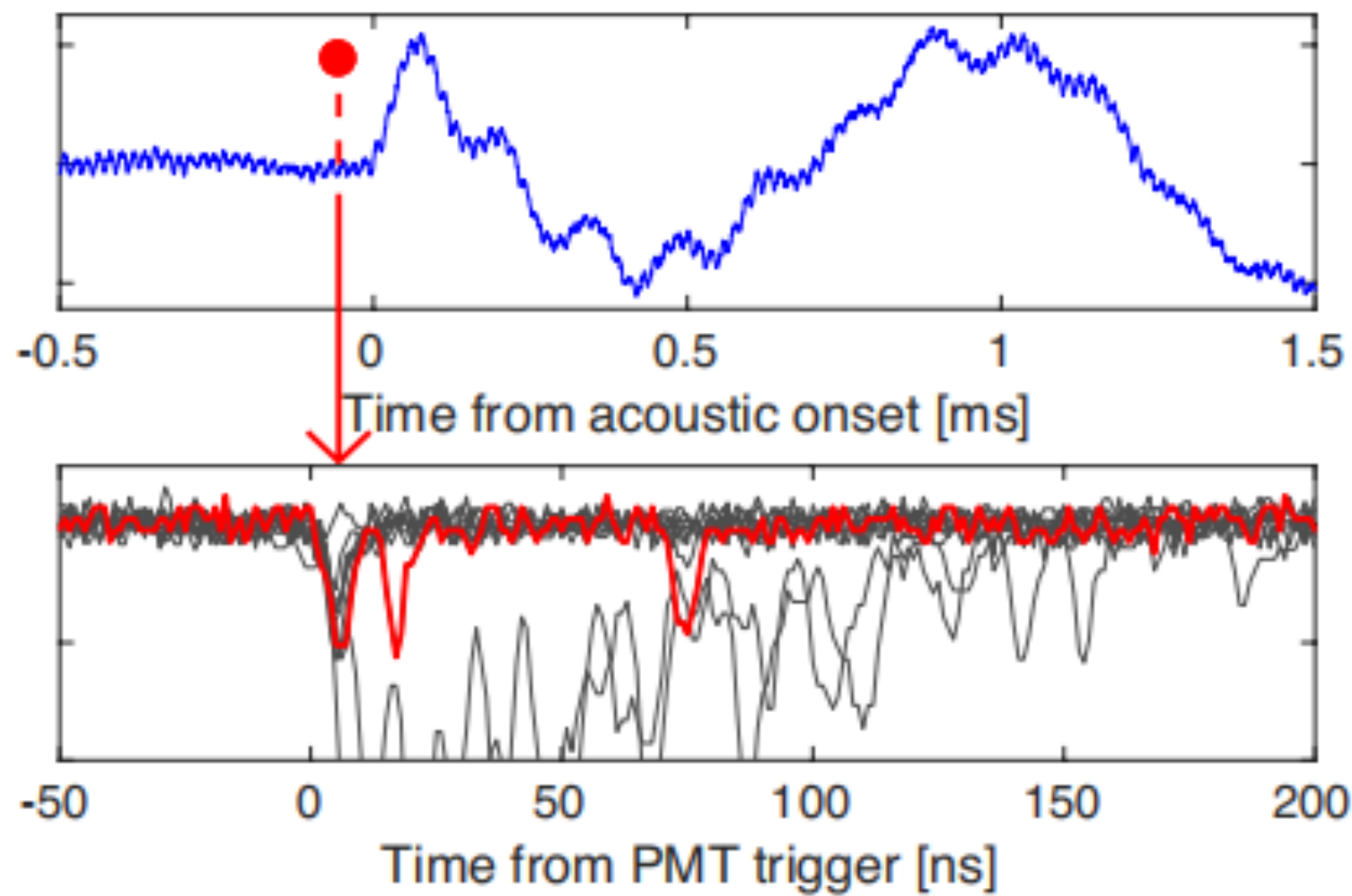
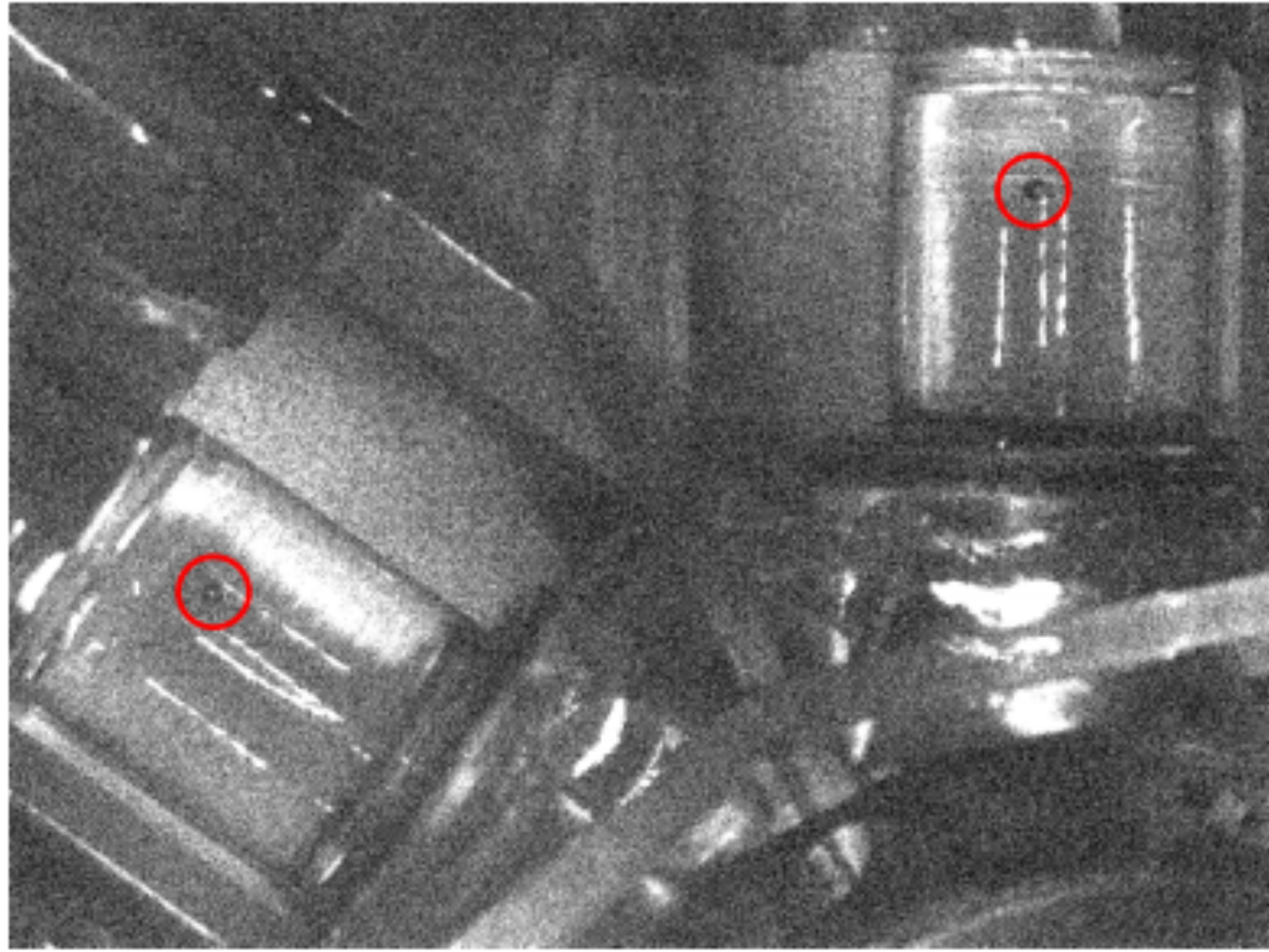

- Roughly 10kg of argon
- SiPMs used for scintillation detection
- Much of the internal detail modelled on PICO 500
- “Only” added challenge is to keep it cold



# Detector Readout Systems

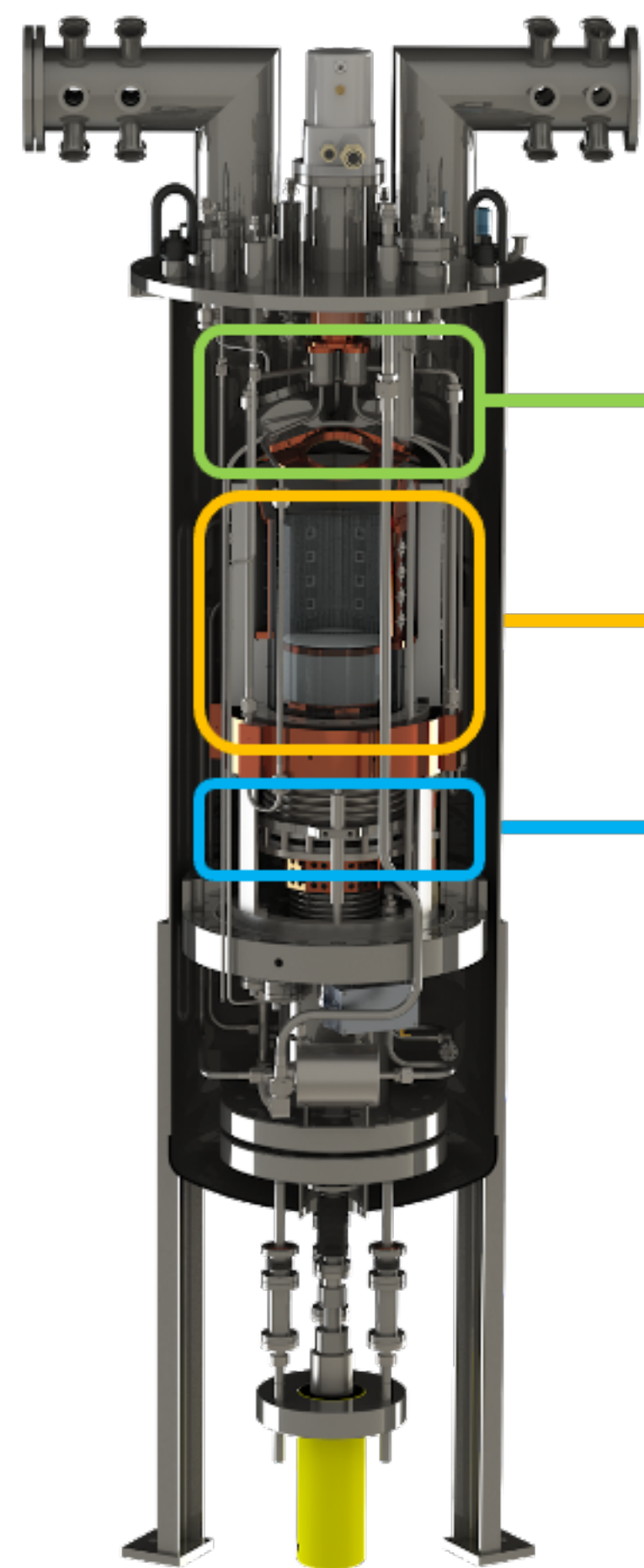

**Bubble Imaging**  
3 Raspberry-Pi Cameras + LEDs

This panel contains three images. The top image is a 3D model of a camera lens assembly. The middle image is a 3D cutaway of the detector showing three camera modules (colored purple, yellow, and blue) positioned around the central chamber. The bottom image is a photograph of a camera lens mounted in a metal housing.

**Scintillation System**  
32 VUV4 Hamamatsu SiPMs

This panel contains two images. The top image is a photograph of a small, square silicon photomultiplier (SiPM) sensor held by a gloved hand. The bottom image is a 3D cutaway of the detector showing a cylindrical array of 32 SiPM sensors mounted on the inner wall of the detector chamber.

**Acoustic Sensors**  
8 Piezoelectric Transducers

This panel contains two images. The top image is a photograph of a piezoelectric transducer, a small cylindrical component with a copper top and a white base, held by a gloved hand. The bottom image is a 3D cutaway of the detector showing eight piezoelectric transducers mounted on the inner wall of the detector chamber.

# Noble liquids and the WIMP search

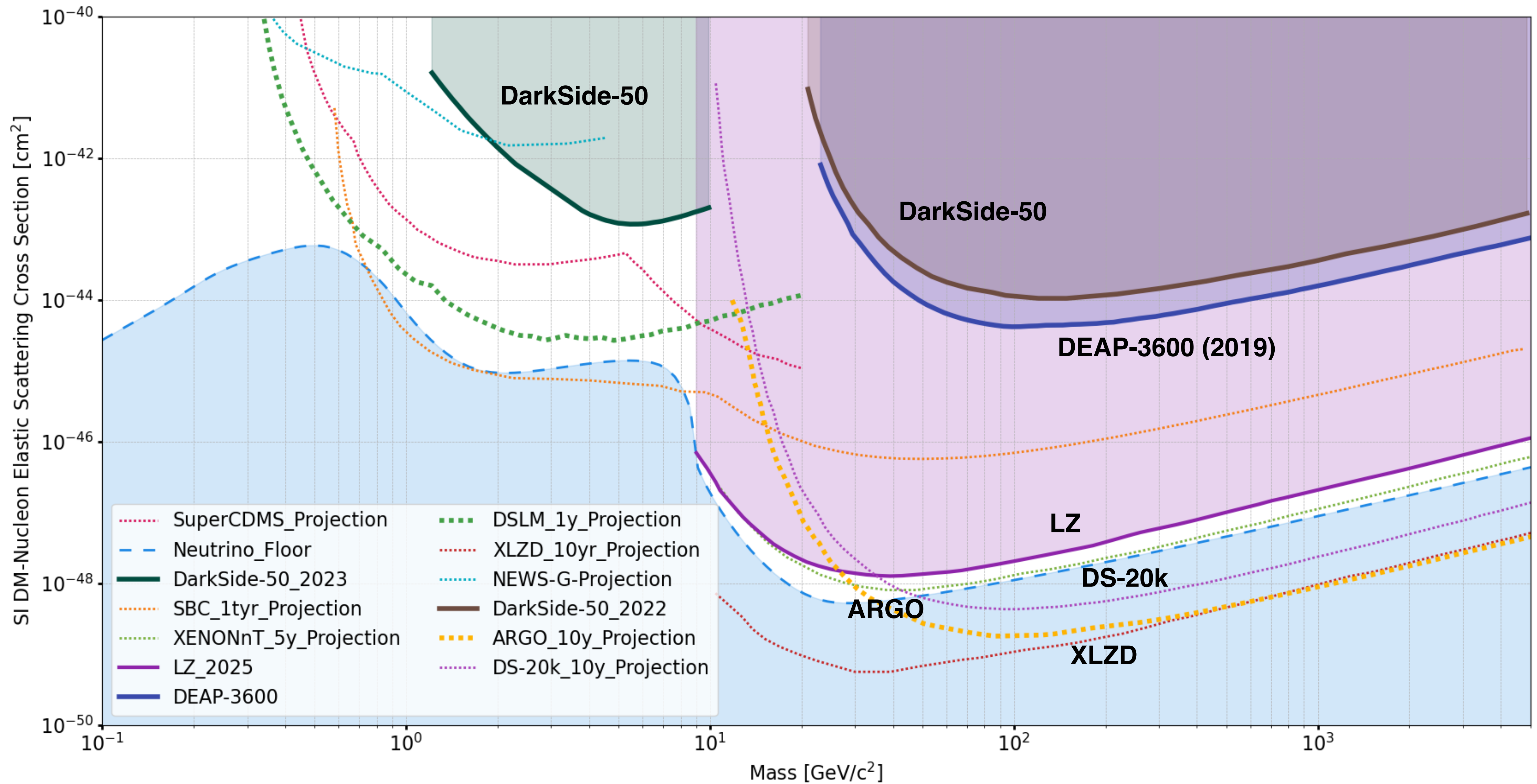

# Other applications

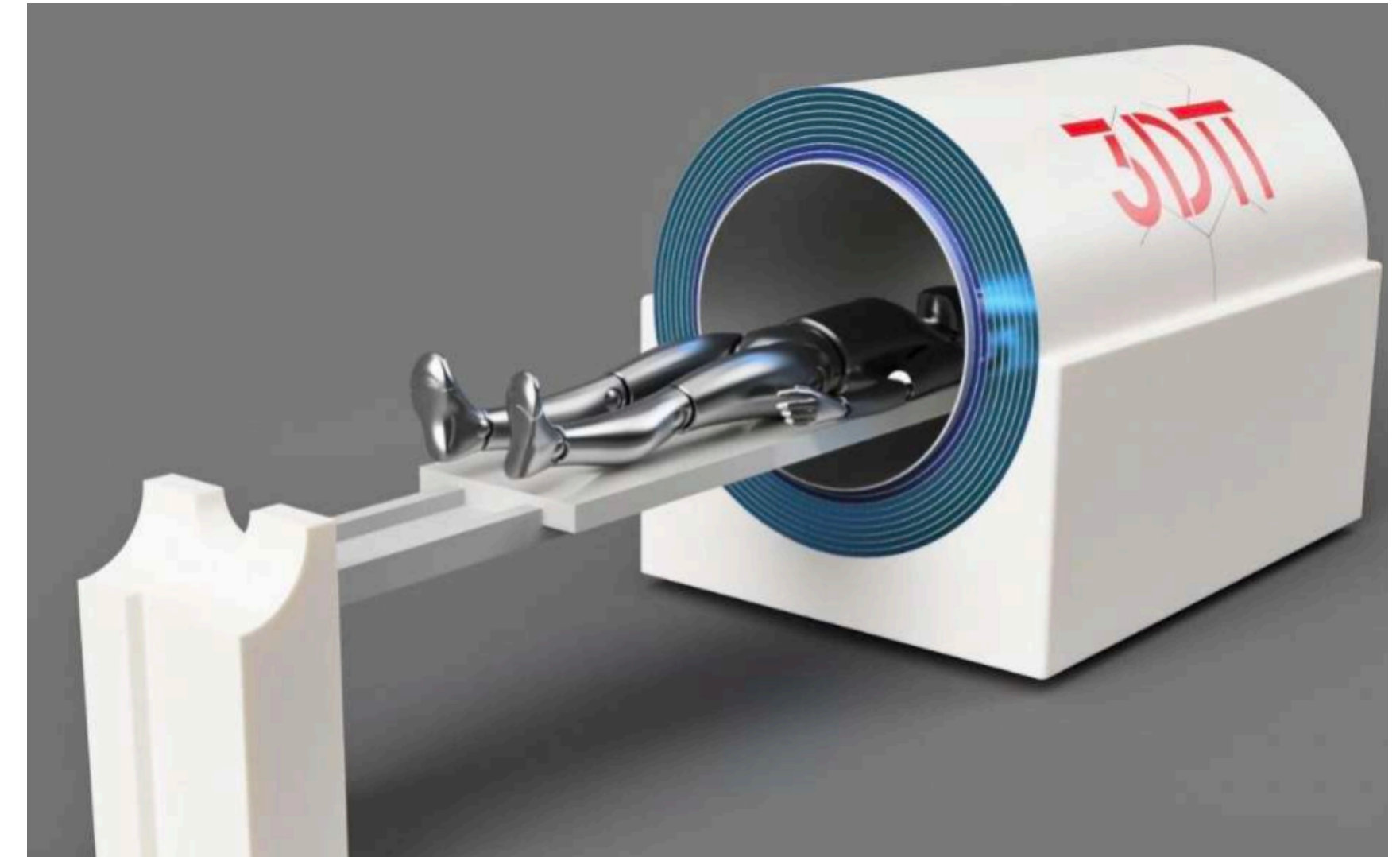
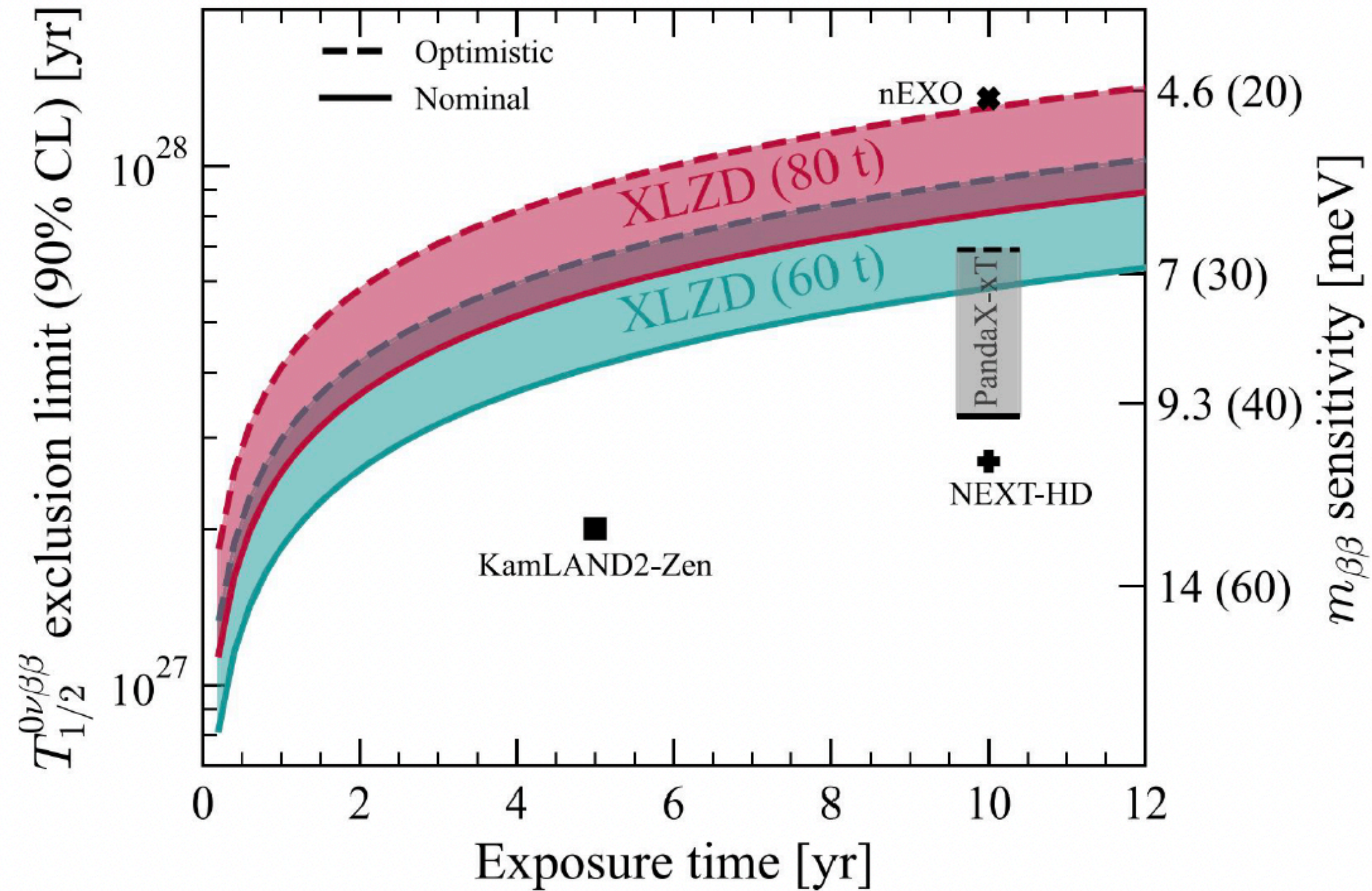

PoS EPS-HEP2021 (2022) 778

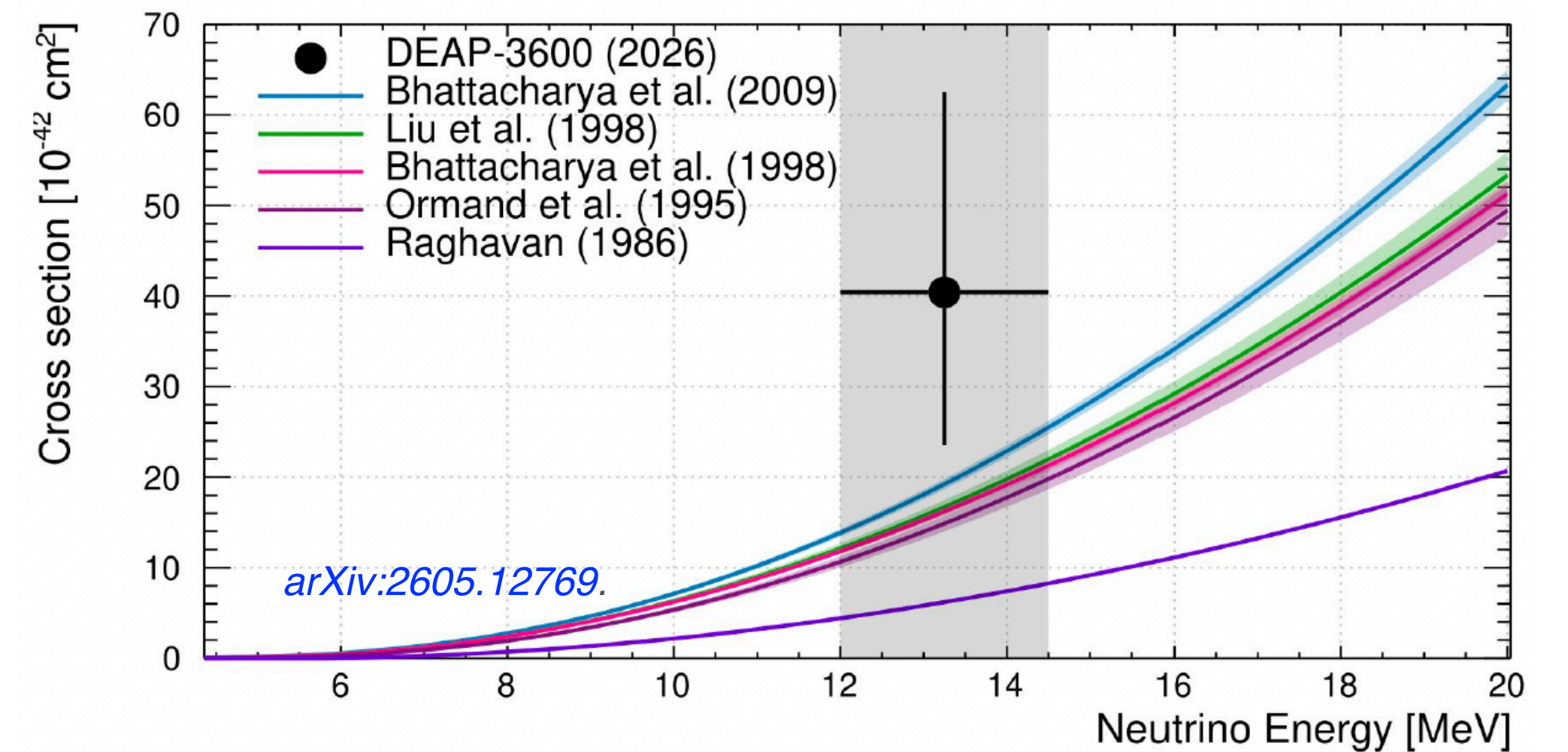
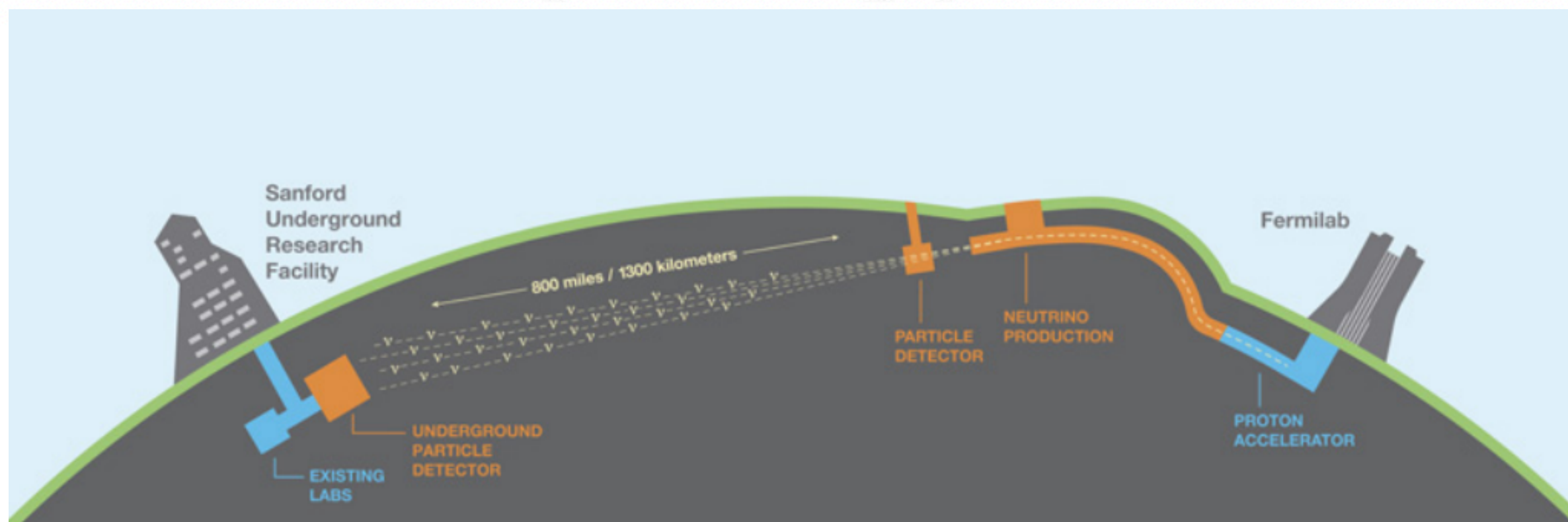

# Other

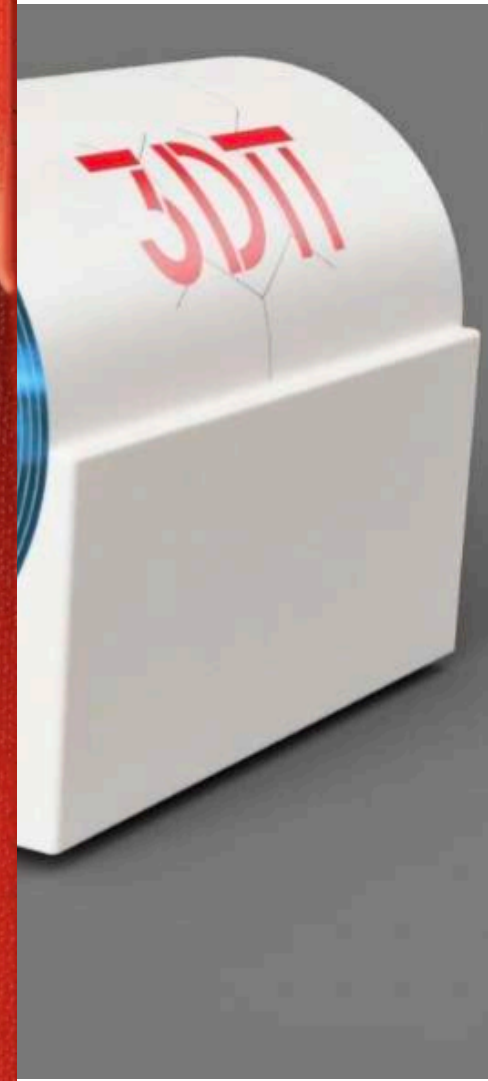
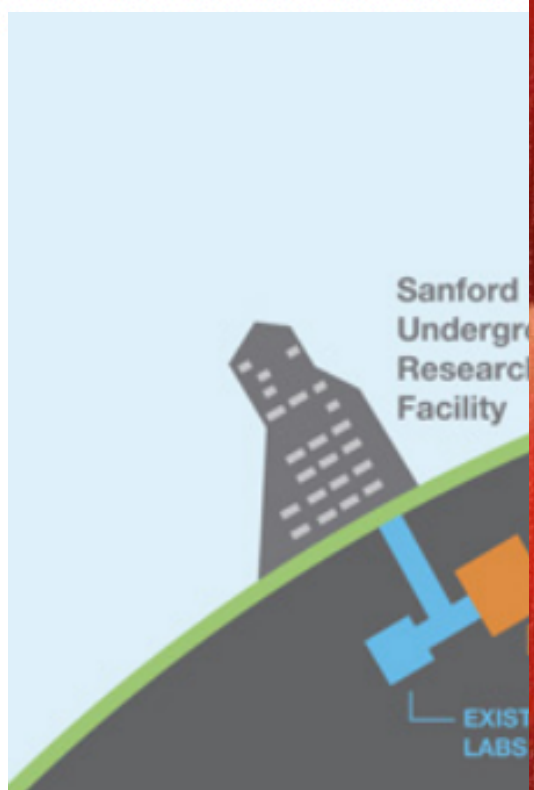
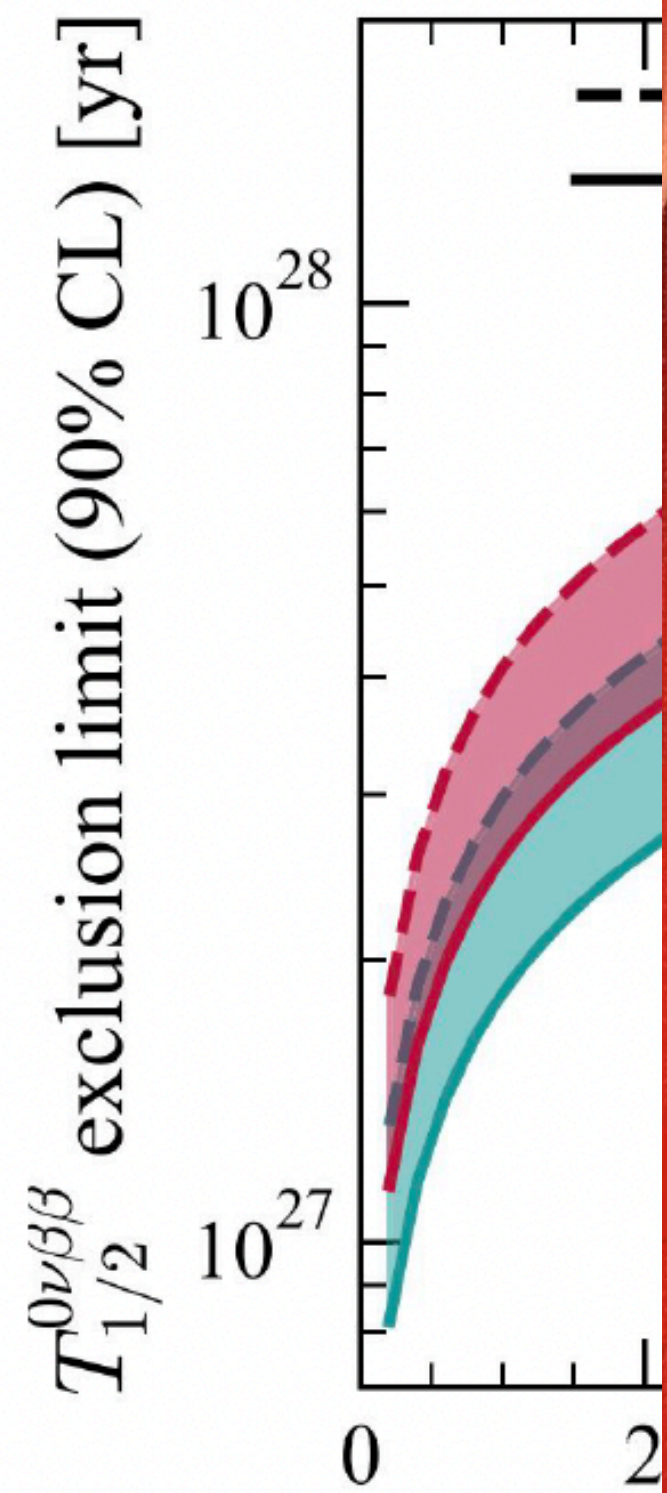

22) 778

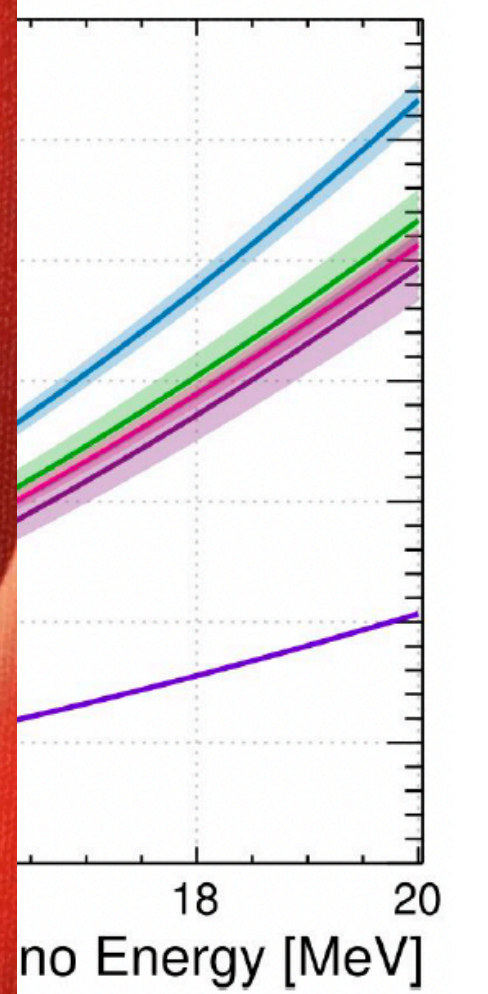

# Other

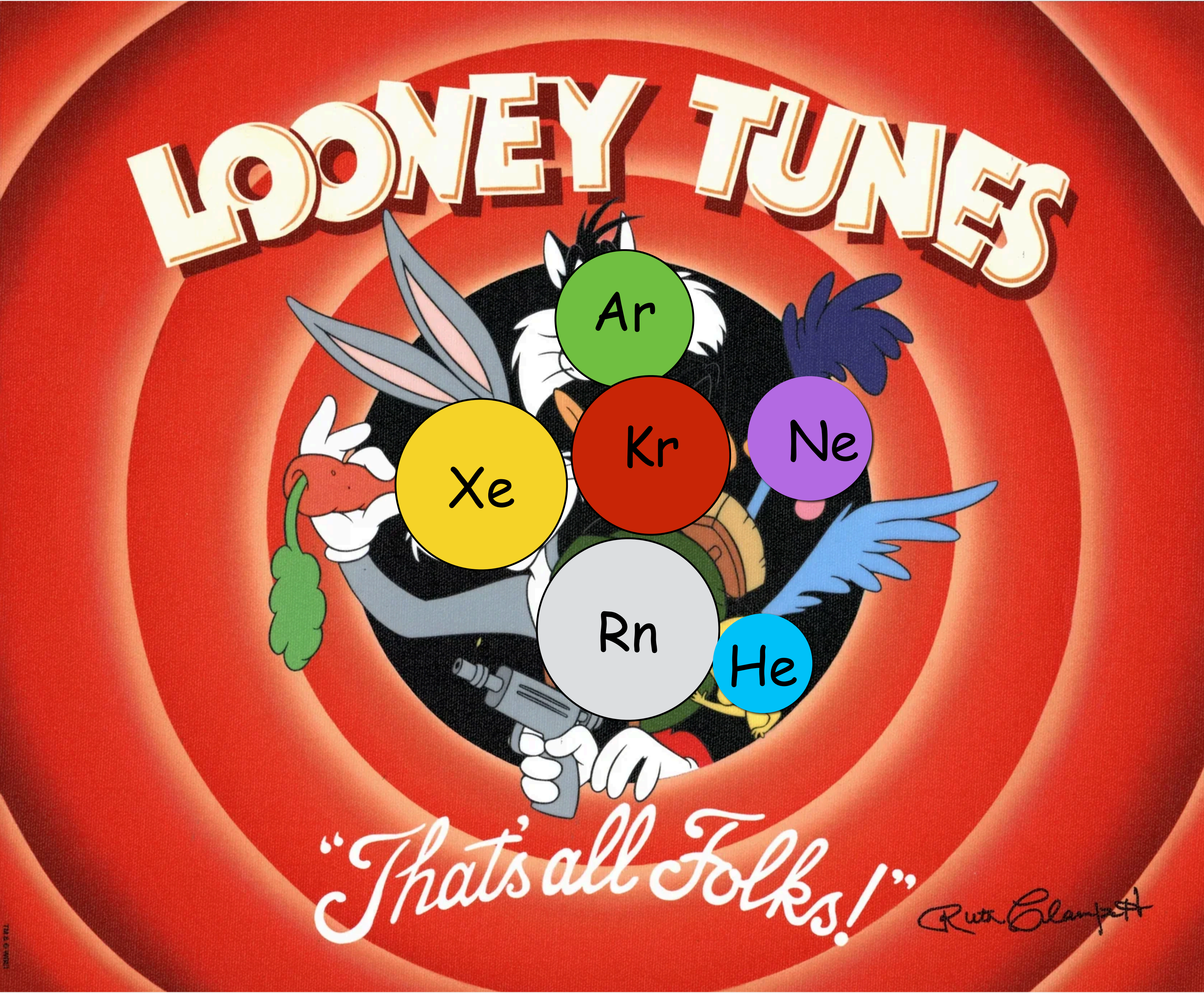
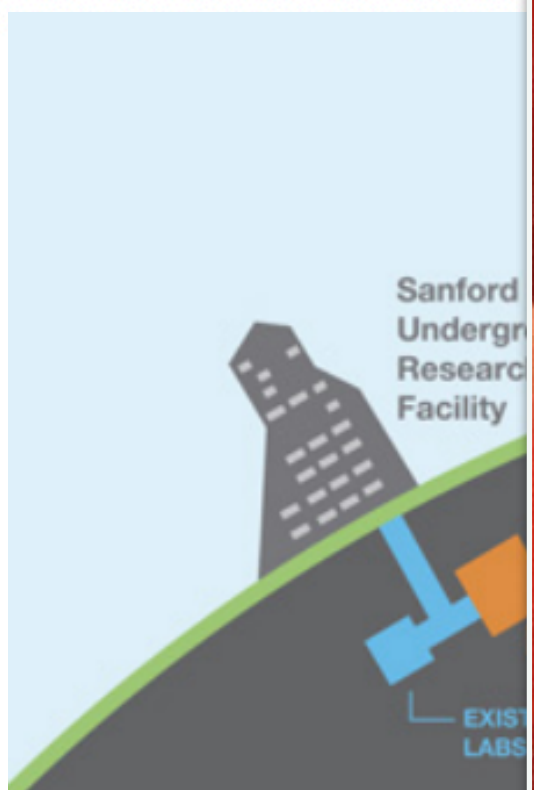
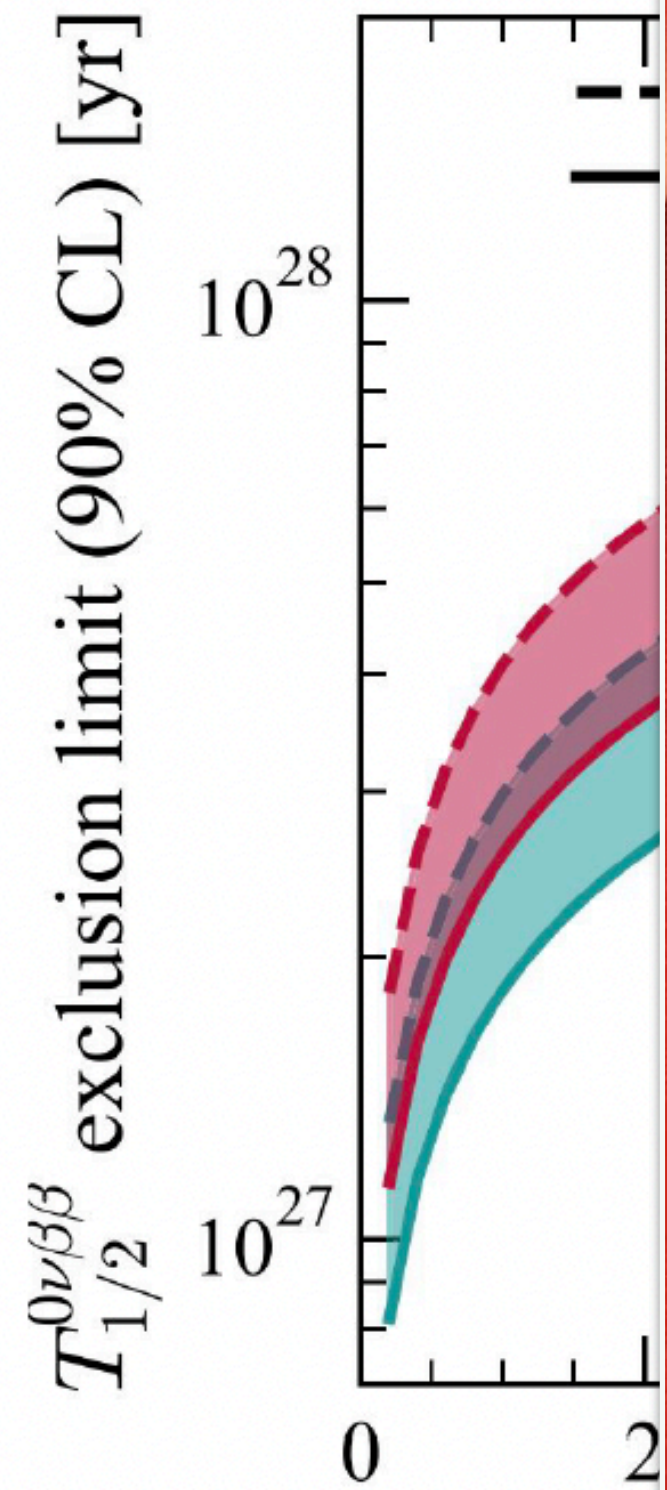

22) 778

